

Proposed Wellington City District Plan

Consolidated Officer Chapter

Recommendations

Hearing Stream 4 topics

Chapters included:

- Wind
- Neighbourhood Centre Zone
- Local Centre Zone
- Commercial Zone
- Mixed Use Zone
- Metropolitan Centre Zone
- City Centre Zone
- Waterfront zone
- General Industrial Zone
- DEV1 – Kilbirnie Bus barns
- APP8 - Quantitative Wind Study and Qualitative Wind Assessment – Modelling and Reporting Requirements
- APP9 - City Centre Zone & Special Purpose Waterfront Zone – Minimum Sunlight Access – Public Space Requirements
- APP11 Kilbirnie Bus Barns Development Plan
- APP14 – Wind Chapter Best Practice Guidance Document
- **NEW** - APP16 City Outcomes Contribution

This entire chapter has been notified as part of an Intensification Planning Instrument, using the Intensification Streamlined Planning Process (ISPP) in accordance with Section 80E of the RMA.

Ngā Hau

Wind

WIND	Wind
-------------	-------------

Introduction

The purpose of the Wind Chapter is to manage new developments, additions and alterations so as to maintain or enhance comfortable and safe wind conditions for pedestrians and public space users. The management of building design for wind effects provides environmental benefits for people and communities.

Wellington’s windy climate necessitates management of new development in order to manage the ground level wind effects in urban areas. New development, particularly buildings that are much larger than their surroundings, can cause downdrafts and channelling, which accelerates winds at ground level. This can negatively affect pedestrian-level comfort and even become hazardous. The taller a building is, the greater its exposure to higher wind speeds, which increases its impact on the ground level winds around it and requires greater wind mitigation measures through building design.

Adverse wind conditions can be often mitigated through the design of buildings. Architectural devices and structures added to a building may also assist in reducing high speed winds and provide protection for pedestrians.

Proposals which include additions or alterations to an existing building or construction of a new building must have regard to the Wind Chapter Best Practice Guidance Document (Appendix 14) in order to achieve optimum building design for wind that minimises the impact of the development on the public realm and achieves wind mitigation that is contained within the site.

The provisions within this chapter apply to public spaces in a number of zones across the City including the City Centre ~~Zone, and different some~~ Centres Zones, ~~and the High Density Residential Zone, Waterfront Zone, Port Zone, Stadium Zone, Hospital Zone and the Tertiary Education Zone. For the Tertiary Education Zone and Hospital Zone, the wind provisions are limited to managing the wind effects of developments on adjacent legal roads.~~ The provisions do not apply to private spaces such as adjacent properties or backyards.

Within these zones, Council encourages the consideration of wind effects and aerodynamics early in the design phase for all additions and alterations to existing buildings and any construction of a new building. The provisions seek to manage the individual and cumulative effects of new building works, additions and alterations on pedestrian amenity, comfort, safety and the progressive deterioration of the wind environment.

Quantitative wind studies (~~wind tunnel testing~~) or qualitative (~~descriptive~~) wind assessments ~~are required when triggered by developments of different scales to may be required~~ to understand the effects of a development on wind conditions. ~~The type of assessment and information requirements are detailed in the relevant rule. For the City Centre Zone, Metropolitan Centre Zone Height Control Area 1, Special Purpose Port Zone, Multi-User Ferry Precinct and Inner Harbour Port Precinct, Special Purpose Stadium Zone and Special Purpose Waterfront Zone, a quantitative wind study will usually be required to show compliance with the wind standards. Council may accept a qualitative wind assessment when a development is likely to have little, if any, impact on wind conditions — refer Wind Chapter Best Practice Guidance Document (Appendix 14) for likely wind effects of buildings.~~

For the Local Centre Zone, Neighbourhood Centre Zone, Metropolitan Centre Zone – excluding Height Control Area 1, Special Purpose Hospital Zone, and Special Purpose Tertiary Education Zone, a qualitative wind assessment is usually all that is required to show compliance with the wind standards. However, if a development is assessed to have a large negative impact on wind conditions, then a quantitative wind study may be required to enable the wind effects of the development to be fully understood.

It is up to the discretion of the Council to decide whether a quantitative wind study or a qualitative wind assessment is required. The requirements for quantitative wind studies and qualitative wind assessments are set out in Appendix 8.

Objectives	
WIND-O1	<p>Purpose</p> <p>The adverse impact of wind from new developments, additions and alterations on public spaces is managed to:</p> <p>1. Provide comfortable conditions for pedestrians whilst acknowledging that not all wind effects can be mitigated;</p> <ol style="list-style-type: none"> 1. Ensure that new developments, additions and alterations do not generate unsafe wind conditions in public spaces and, where possible, ameliorate existing unsafe wind conditions; and 2. Prevent the gradual degradation of Wellington's pedestrian wind environment over time; and 3. <u>Ensure a comfortable wind environment in the public spaces listed in Appendix 9 – City Centre Zone and Special Purpose Waterfront Zone – Minimum Sunlight Access and Wind Comfort Control – Public Space Requirements, while acknowledging that not all wind effects can be mitigated.</u>
Policies	
WIND-P1	<p>Early consideration of wind in design</p> <p>Encourage consideration of wind effects during the early stages of building design to achieve:</p> <ol style="list-style-type: none"> 1. Optimum design for wind that minimises the impact of the development on the public realm; and 2. Wind mitigation that is contained within the site.
WIND-P2	<p>Managing effects</p> <p>Require that larger-scale buildings, including additions and alterations, are designed to:</p> <ol style="list-style-type: none"> 1. Manage adverse wind effects that they create; 2. Improve the wind environment as far as practical ble where existing wind conditions are dangerous; and 3. Limit any deterioration of the wind environment that eaffects: <ol style="list-style-type: none"> a. The Ssafety and amenity of the pedestrians s <u>experience</u>; and b. Existing wind mitigation measures.
WIND-P3	<p>Comfort and safety in <u>listed</u> public spaces</p> <p>Require building design and wind mitigation measures to maintain and where possible enhance pedestrian safety and the comfort of the wind environment for users of the public spaces listed in <u>Appendix 9 – City Centre Zone and Special Purpose Waterfront Zone – Minimum Sunlight Access and Wind Comfort Control – Public Space Requirements.</u></p>
WIND-P4	<p>Comfort and safety in public spaces created through new development</p>

	Encourage new public spaces created through new development to have wind conditions that are appropriate for the expected public use of the space.
WIND-P5	<p><u>Developments in the Hospital Zone and Tertiary Education Zone that are adjacent to legal roads</u></p> <p><u>Require that developments in the Hospital Zone and Tertiary Education Zone that are adjacent to legal roads be designed to:</u></p> <ol style="list-style-type: none"> 1. <u>Manage adverse wind effects they create;</u> 2. <u>Improve the wind environment as far as practicable where existing wind conditions are dangerous;</u> 3. <u>Limit any deterioration of the wind environment that is adjacent to legal roads that affects:</u> <ol style="list-style-type: none"> a. <u>The safety of the pedestrian experience using adjacent legal roads; and</u> b. <u>Existing wind mitigation measures.</u>
Building and Structure Activities	
WIND-R1	Construction, alteration and additions to buildings and structures
<p>City Centre Zone</p> <p>Metropolitan Centre Zone - Height Control Area 1 and 2</p> <p>Port Zone: Inner Harbour Port Precinct</p> <p>Port Zone: Multi-User Ferry Precinct</p> <p>Waterfront Zone</p> <p>Stadium Zone</p>	<p>1. Activity status: Permitted</p> <p>Where:</p> <ol style="list-style-type: none"> a. New or altered buildings or structures are less than or equal to 20m in height above ground level; or b. Rooftop aAdditions: <ol style="list-style-type: none"> i. The height of the rooftop additions are less than or equal to 8m in height when measured from the highest point of the building or structure; or ii. Are setback at least 5m from the building facades adjacent to public spaces and d. Are less than 33% of the existing building volume.; or e. Compliance with the following standards is achieved: <ol style="list-style-type: none"> i. WIND-S1; ii. WIND-S2; and iii. WIND-S3.
<p>Local Centre Zone</p> <p>Neighbourhood Centre Zone</p> <p>Metropolitan Centre Zone - excluding Metropolitan Centre Zone Height Control Area 1 and 2</p> <p><u>High Density Residential Zone</u></p>	<p>2. Activity status: Permitted</p> <p>Where:</p> <ol style="list-style-type: none"> a. New or altered buildings or structures are less than or equal to 42m <u>15m</u> in height above ground level; or b. Rooftop aAdditions: <ol style="list-style-type: none"> i. The height of the rooftop additions are less than or equal to 4m; or in height when measured from the highest point of the building or structure; or e. Rooftop additions aAre setback at least 3m from the building facades adjacent to public spaces and d. are less than 33% of the existing building volume.; or e. Compliance with the following standards is achieved: <ol style="list-style-type: none"> i. WIND-S1; and ii. WIND-S2.

<p>Hospital Zone</p> <p>Tertiary Education Zone</p>	<p>3. Activity status: Permitted</p> <p><u>a. Where all of the building or structure is more than 20 metres from a legal road; or</u> <u>b. Where any part of the building or structure is within 20 metres of development is adjacent to a legal road public street:</u></p> <p>a.i. New or altered buildings or structures are less than or equal to 42m <u>15m</u> in height above ground level; or b.ii. <u>Rooftop additions:</u></p> <ul style="list-style-type: none"> • a.i. <u>The height of the rooftop additions are less than or equal to 4m; or in height when measured from the highest point of the building or structure; or</u> • c.ii. <u>Rooftop additions are</u> setback at least 3m from the building facades adjacent to public spaces; and <p>a.d. are less than 33% of the existing building volume; or e. <u>Compliance with the following standards is achieved:</u></p> <ul style="list-style-type: none"> i. <u>WIND-S1; and</u> ii. <u>WIND-S2.</u>
<p><u>City Centre Zone</u></p> <p><u>Waterfront Zone</u></p>	<p>4. Activity status: Restricted Discretionary</p> <p><u>Where:</u></p> <ul style="list-style-type: none"> a. <u>Compliance with WIND-R1.1 cannot be achieved; or</u> b. <u>New buildings and structures exceed 20m above ground level, but are less than 25m above ground level.</u> <p><u>Matters of discretion are:</u></p> <ul style="list-style-type: none"> 1. <u>The extent and effect of non-compliance with WIND-S1, WIND-S2 and WIND-S3 as specified in the associated assessment criteria for the infringed standard.</u> 2. <u>The matters in WIND-P1, WIND-P2, WIND-P3 and WIND-P4;</u> 3. <u>The extent of compliance with qualitative wind assessment requirements included in Appendix 8; and</u> 4. <u>The level of consistency with the Wind Chapter Best Practice Guidance Document (Appendix 14).</u> <p><u>Section 88 Information Requirements</u></p> <p><u>Applications under this rule must provide either a qualitative wind assessment or a quantitative wind study that:</u></p> <ul style="list-style-type: none"> 1. <u>Details the extent of compliance with WIND-S1, WIND-S2 and WIND-S3;</u> 2. <u>Is based on the expert opinion of a suitably qualified and experienced person;</u> 3. <u>Considers the effects of the proposed building upon all public spaces;</u> 4. <u>Complies with the reporting requirements in Appendix 8 WIND-A2 and be consistent with the 'rules of thumb' for estimating wind effects in the Wind Chapter Best Practice Guidance Document (Appendix 14); and</u> 5. <u>Be consistent with the proposed design in the resource consent application and any associated urban design analysis and landscaping proposals.</u>
<p><u>City Centre Zone</u></p> <p><u>Waterfront Zone</u></p>	<p>5. Activity status: Restricted Discretionary</p> <p><u>Where</u></p> <ul style="list-style-type: none"> 1. <u>Compliance with WIND-R1.1 cannot be achieved; or</u> 2. <u>New buildings and structures exceed 25m above ground level.</u> <p><u>Matters of discretion are:</u></p>

	<ol style="list-style-type: none"> 1. <u>The extent and effect of non-compliance with WIND-S1, WIND-S2 and WIND-S3 as specified in the associated assessment criteria for the infringed standard;</u> 2. <u>The matters in WIND-P1, WIND-P2, WIND-P3 and WIND-P4;</u> 3. <u>The extent of compliance with quantitative wind assessment requirements included in Appendix 8; and</u> 4. <u>The level of consistency with the Wind Chapter Best Practice Guidance Document (Appendix 14).</u> <p><u>Section 88 Information Requirements</u></p> <p><u>Applications under this rule must provide a quantitative wind study assessment that:</u></p> <ol style="list-style-type: none"> 1. <u>Details the extent of compliance with WIND-S1, WIND-S2, and WIND-S3;</u> 2. <u>Where WIND-S1, WIND-S2, and WIND-S3 are not complied with, show how the proposed building most closely complies with these standards when compared to any other practical alternative building design (i.e. it is the optimum aerodynamic design for the site);</u> 3. <u>Is based on the expert opinion of a suitably qualified and experienced person;</u> 4. <u>Complies with the reporting requirements set out in Appendix 8 WIND-A1;</u> 5. <u>Is consistent with the Wind Chapter Best Practice Guidance Document (Appendix 14);</u> 6. <u>Considers the effects of the proposed building upon all public spaces;</u> 7. <u>Compares the effects of the proposed building against the existing situation, except where the site is currently vacant. If the site is vacant, the proposed building must be compared against any building which existed on the site within the previous 5 years; and</u> 8. <u>Be consistent with the proposed design in the resource consent application and any associated urban design analysis and landscaping proposals.</u>
<p><u>Port Zone:</u> <u>Inner Harbour</u> <u>Port Precinct</u></p> <p>-</p> <p><u>Port Zone:</u> <u>Multi-User</u> <u>Ferry Precinct</u></p> <p>-</p> <p><u>Metropolitan</u> <u>Centre Zone</u></p> <p><u>Stadium Zone</u></p>	<ol style="list-style-type: none"> 6. <u>Activity status: Restricted Discretionary</u> <p><u>Where</u></p> <ol style="list-style-type: none"> 1. <u>Compliance with WIND-R1.1 cannot be achieved; or</u> 2. <u>New buildings and structures exceed 20m above ground level, but are less than 25m above ground level.</u> <p><u>Matters of discretion are:</u></p> <ol style="list-style-type: none"> 1. <u>The extent and effect of non-compliance with WIND-S1 and WIND-S2 and as specified in the associated assessment criteria for the infringed standard;</u> 2. <u>The matters in WIND-P1, WIND-P2, WIND-P3 and WIND-P4;</u> 3. <u>The extent of compliance with quantitative wind assessment requirements included in Appendix 8; and</u> 4. <u>The level of consistency with the Wind Chapter Best Practice Guidance Document (Appendix 14).</u> <p><u>Section 88 Information Requirements</u></p> <p><u>Applications under this rule must provide either a qualitative wind assessment or a quantitative wind study that:</u></p> <ol style="list-style-type: none"> 1. <u>Details the extent of compliance with WIND-S1 and WIND-S2;</u> 2. <u>Is based on the expert opinion of a suitably qualified and experienced person;</u> 3. <u>Considers the effects of the proposed building upon all public spaces;</u> 4. <u>Complies with the reporting requirements in Appendix 8 WIND-A2 and be consistent with the 'rules of thumb' for estimating wind effects in the Wind Chapter Best Practice Guidance Document (Appendix 14); and</u>

	<p>5. <u>Be consistent with the proposed design in the resource consent application and any associated urban design analysis and landscaping proposals.</u></p>
<p><u>Port Zone:</u> <u>Inner Harbour Port Precinct</u></p> <p><u>Port Zone:</u> <u>Multi-User Ferry Precinct</u></p> <p><u>Metropolitan Centre Zone</u></p> <p><u>Stadium Zone</u></p>	<p>7. <u>Activity status: Restricted Discretionary</u></p> <p><u>Where</u></p> <ol style="list-style-type: none"> 1. <u>Compliance with WIND-R1.1 cannot be achieved; or</u> 2. <u>New buildings and structures exceed 25m above ground level.</u> <p><u>Matters of discretion are:</u></p> <ol style="list-style-type: none"> 1. <u>The extent and effect of non-compliance with WIND-S1 and WIND-S2 as specified in the associated assessment criteria for the infringed standard;</u> 2. <u>The matters in WIND-P1, WIND-P2, WIND-P3 and WIND-P4;</u> 3. <u>The extent of compliance with quantitative wind assessment requirements included in Appendix 8; and</u> 4. <u>The level of consistency with the Wind Chapter Best Practice Guidance Document (Appendix 14).</u> <p><u>Section 88 Information Requirements</u></p> <p><u>Applications under this rule must provide a quantitative wind assessment study that:</u></p> <ol style="list-style-type: none"> 1. <u>Details the extent of compliance with WIND-S1 and WIND-S2;</u> 2. <u>Where WIND-S1 and WIND-S2 are not complied with, show how the proposed building most closely complies with these standards when compared to any other practical alternative building design (i.e. it is the optimum aerodynamic design for the site);</u> 3. <u>Is based on the expert opinion of a suitably qualified and experienced person;</u> 4. <u>Complies with the reporting requirements set out in Appendix 8 WIND-A1;</u> 5. <u>Is consistent with the Wind Chapter Best Practice Guidance Document (Appendix 14);</u> 6. <u>Considers the effects of the proposed building upon all public spaces;</u> 7. <u>Compares the effects of the proposed building against the existing situation, except where the site is currently vacant. If the site is vacant, the proposed building must be compared against any building which existed on the site within the previous 5 years; and</u> 8. <u>Be consistent with the proposed design in the resource consent application and any associated urban design analysis and landscaping proposals.</u>
<p><u>Local Centre Zone</u></p> <p><u>Neighbourhood Centre Zone</u></p> <p><u>High Density Residential Zone</u></p> <p><u>Tertiary Education Zone</u></p> <p><u>Hospital Zone</u></p>	<p>8. <u>Activity status: Restricted Discretionary</u></p> <p><u>Where:</u></p> <ol style="list-style-type: none"> c. <u>Compliance with WIND-R1.2 or WIND-R1.3 cannot be achieved; or</u> d. <u>New buildings and structures exceed 15m above ground level, but are less than 25m above ground level.</u> <p><u>Matters of discretion are:</u></p> <ol style="list-style-type: none"> 1. <u>The extent and effect of non-compliance with WIND-S1 and WIND-S2 as specified in the associated assessment criteria for the infringed standard.</u> 2. <u>The matters in WIND-P1, WIND-P2, WIND-P3 and WIND-P4;</u> 3. <u>The extent of compliance with qualitative wind assessment requirements included in Appendix 8; and</u> 4. <u>The level of consistency with the Wind Chapter Best Practice Guidance Document (Appendix 14).</u>

	<p><u>Section 88 Information Requirements</u></p> <p><u>Applications under this rule must provide either a qualitative wind assessment or a quantitative wind study that:</u></p> <ol style="list-style-type: none"> 1. <u>Details the extent of compliance with WIND-S1 and WIND-S2;</u> 2. <u>Is based on the expert opinion of a suitably qualified and experienced person;</u> 3. <u>Considers the effects of the proposed building upon all public spaces;</u> 4. <u>Complies with the reporting requirements in Appendix 8 WIND-A2 and be consistent with the ‘rules of thumb’ for estimating wind effects in the Wind Chapter Best Practice Guidance Document (Appendix 14); and</u> 5. <u>Be consistent with the proposed design in the resource consent application and any associated urban design analysis and landscaping proposals.</u>
<p><u>Local Centre Zone</u></p> <p><u>Neighbourhood Centre Zone</u></p> <p><u>High Density Residential Zone</u></p> <p><u>Tertiary Education Zone</u></p> <p><u>Hospital Zone</u></p>	<p>9. <u>Activity status: Restricted Discretionary</u></p> <p><u>Where</u></p> <ol style="list-style-type: none"> 1. <u>Compliance with WIND-R1.2 or WIND-1.3 cannot be achieved; or</u> 2. <u>New buildings and structures exceed 25m above ground level.</u> <p><u>Matters of discretion are:</u></p> <ol style="list-style-type: none"> 5. <u>The extent and effect of non-compliance with WIND-S1 and WIND-S2 as specified in the associated assessment criteria for the infringed standard;</u> 6. <u>The matters in WIND-P1, WIND-P2, WIND-P3 and WIND-P4;</u> 7. <u>The extent of compliance with quantitative wind assessment requirements included in Appendix 8; and</u> 8. <u>The level of consistency with the Wind Chapter Best Practice Guidance Document (Appendix 14).</u> <p><u>Section 88 Information Requirements</u></p> <p><u>Applications under this rule must provide a quantitative wind assessment study that:</u></p> <ol style="list-style-type: none"> 1. <u>Details the extent of compliance with WIND-S1 and WIND-S2;</u> 2. <u>Where WIND-S1 and WIND-S2 are not complied with, show how the proposed building most closely complies with these standards when compared to any other practical alternative building design (i.e. it is the optimum aerodynamic design for the site);</u> 3. <u>Is based on the expert opinion of a suitably qualified and experienced person;</u> 4. <u>Complies with the reporting requirements set out in Appendix 8 WIND-A1;</u> 5. <u>Is consistent with the Wind Chapter Best Practice Guidance Document (Appendix 14);</u> 6. <u>Considers the effects of the proposed building upon all public spaces;</u> 7. <u>Compares the effects of the proposed building against the existing situation, except where the site is currently vacant. If the site is vacant, the proposed building must be compared against any building which existed on the site within the previous 5 years; and</u> 8. <u>Be consistent with the proposed design in the resource consent application and any associated urban design analysis and landscaping proposals.</u>
<p><u>City Centre Zone</u></p> <p>-</p>	<p>4. <u>Activity status: Restricted Discretionary</u></p> <p><u>Where:</u></p>

<p>Metropolitan Centre Zone - Local Centre Zone - Neighbourhood Centre Zone - Port Zone: Inner Harbour Port Precinct - Port Zone: Multi-User Ferry Precinct - Waterfront Zone - Stadium Zone - Hospital Zone - Tertiary Education Zone</p>	<p>a. Compliance with WIND-R1.1 or WIND-R1.2 or WIND-R1.3 cannot be achieved</p> <p>Matters of discretion are:</p> <ol style="list-style-type: none"> 1. The matters in WIND-P1, WIND-P2, WIND-P3 and WIND-P4; 2. The extent and effect of non-compliance with any relevant standard as specified in the associated assessment criteria for the infringed standard; 3. The extent of compliance with the quantitative wind study and qualitative wind assessment requirements included in Appendix 8; and 4. The level of consistency with the Wind Chapter Best Practice Guidance Document (Appendix 14). <p>Section 88 information requirements for applications:</p> <ol style="list-style-type: none"> 2. For the City Centre Zone, Stadium Zone, Port Zone, Multi-User Ferry Precinct, Inner Harbour Port Precinct, Waterfront Zone and Metropolitan Centre Zone—Height Control Area 1 and 2, applications under this rule must provide, in addition to the standard information requirements: <ol style="list-style-type: none"> 1. A wind report, which is based on the results of a quantitative wind study, must be submitted to show compliance with WIND-S1, WIND-S2, and WIND-S3; and 2. The wind report must address the wind report information requirements set out in Appendix 8 WIND-A1 and: <ol style="list-style-type: none"> a. Be based on the results of testing that complies with the requirements given in Appendix 8 WIND-A1; b. Show the effects of the proposed building upon all public spaces; c. Compare the effects of the proposed building against the existing situation, except where the site is currently vacant. If the site is vacant, the proposed building must be compared against any building which existed on the site within the previous 5 years; d. Where WIND-S1, WIND-S2, or where applicable WIND-S3, is not complied with, show how the proposed building most closely complies with these standards when compared to any other practical alternative building design (i.e. it is the optimum aerodynamic design for the site); e. Comply with the reporting requirements in Appendix 8 WIND-A1 and be consistent with the Wind Chapter Best Practice Guidance Document (Appendix 14); and f. Be consistent with the proposed design in the resource consent application and any associated urban design analysis and landscaping proposals. 3. For the Local Centre Zone, Neighbourhood Centre Zone, Metropolitan Centre Zone—excluding Metropolitan Centre Zone Height Control Area 1 and 2, Hospital Zone, and Tertiary Education Zone, applications under this rule must provide, in addition to the standard information requirements: <ol style="list-style-type: none"> 1. A qualitative wind assessment, and certification must be submitted to show compliance with WIND-S1 and WIND-S2; and 2. The qualitative wind assessment must: <ol style="list-style-type: none"> a. Be based on the expert opinion of a suitably qualified and experienced person; and b. Consider the effects of the proposed building upon all public spaces; and c. Detail the extent of compliance with WIND-S1 and WIND-S2; and d. Comply with the reporting requirements in Appendix 8 WIND-A2 and be consistent with the ‘rules of thumb’ for estimating wind effects in the Wind Chapter Best Practice Guidance Document (Appendix 14); and e. Be consistent with the proposed design in the resource consent application and any associated urban design analysis and landscaping proposals.
<p>WIND-R2</p>	<p>Construction, alteration and additions to buildings and structures <u>not otherwise provided for in this chapter</u></p>
<p>All zones <u>not otherwise</u></p>	<p>1. Activity status: Permitted</p>

listed in WIND-R1		
Effects Standards		
WIND-S1	Safety	
City Centre Zone Metropolitan Centre Zone Local Centre Zone Neighbourhood Centre Zone Port Zone: Inner Harbour Port Precinct Port Zone: Multi-User Ferry Precinct Waterfront Zone Stadium Zone Hospital Zone Tertiary Education Zone High Density Residential Zone	1. The proposed building, additions or alterations must not result in an annual maximum gust speed in excess of 20 m/s in any public space.	Assessment criteria where the standard is infringed: <ol style="list-style-type: none"> 1. The extent to which pedestrians can easily avoid dangerous gust speeds created by the proposed development, including effects on building entrances, pedestrian crossings, or major walking routes; 2. The extent to which pedestrian use in areas where dangerous wind speeds occur is low and wind conditions elsewhere are improved by the proposed development; 3. The extent to which dangerous wind speeds at one location results from wind being redirected or shifted from another location, with no significant change in the overall wind conditions; 4. The extent to which an existing dangerous gust speed is reduced, improving the overall wind conditions; 5. The extent to which it is shown that the proposed design is the optimum aerodynamic solution, including whether changes in bulk or location of the proposed development are documented and do not significantly improve the situation; and 6. The extent to which the proposed development design is consistent with the Wind Chapter Best Practice Guidance Document (Appendix 14).
WIND-S2	Deterioration of the wind environment	
City Centre Zone Metropolitan Centre Zone Local Centre Zone Neighbourhood Centre Zone Port Zone: Inner Harbour Port Precinct	1. Wind conditions overall must not deteriorate in public spaces that are affected by the development when undesirable wind conditions are assessed by the number of hours a mean wind speed of 2.5 m/s is equaled or exceeded each year; and 2. Wind conditions at any specific locations may deteriorate by up to 500 hours per year, provided the wind conditions averaged over all the public spaces do not deteriorate.	Assessment criteria where the standard is infringed: <ol style="list-style-type: none"> 1. The extent to which pedestrians can easily avoid dangerous gust speeds created by the proposed development, including effects on building entrances, pedestrian crossings, or major walking routes; 2. The extent to which pedestrian use in areas where dangerous wind speeds occur is low and wind conditions elsewhere are improved by the proposed development; 3. The extent to which dangerous wind speeds at one location results from wind being redirected or shifted from

<p>Port Zone: Multi-User Ferry Precinct</p> <p>Waterfront Zone</p> <p>Stadium Zone</p> <p>Hospital Zone</p> <p>Tertiary Education Zone</p> <p><u>High Density Residential Zone</u></p>		<p>another location, with no significant change in the overall wind conditions;</p> <ol style="list-style-type: none"> 4. The extent to which existing wind conditions are maintained or improved; 5. The extent to which it is shown that the proposed design is the optimum aerodynamic solution, including whether changes in bulk or location of the proposed development are documented and do not significantly improve the situation; and 6. The extent to which the proposed development design is consistent with the Wind Chapter Best Practice Guidance Document (Appendix 14).
<p>WIND-S3</p>	<p>Comfort</p>	
<p>WIND-S3 applies to Public spaces listed in Appendix 9 City Centre Zone and Special Purpose Waterfront Zone – Minimum Sunlight Access <u>and</u> <u>Wind Comfort Control</u> – Public Space Requirements.</p>	<ol style="list-style-type: none"> 1. A proposed development must not cause uncomfortable wind conditions in <u>listed</u> public spaces; and 2. A development must not cause existing uncomfortable wind conditions to deteriorate. 	<p>Assessment criteria where the standard is infringed:</p> <ol style="list-style-type: none"> 1. The extent to which pedestrians can easily avoid areas where winds deteriorate and use other areas where the winds do not deteriorate; 2. The extent to which pedestrian use and expectations for the area where winds deteriorate are low and wind conditions elsewhere improve. 3. The extent to which a deterioration in winds at one location results from wind being redirected or shifted from one area to another, with no significant change in the overall wind conditions; 4. The extent to which existing wind conditions have been maintained or improved; 5. The extent to which very low existing winds speeds have been increased towards the comfort threshold; 6. The extent to which it is shown that the proposed design is the optimum aerodynamic solution, e.g. changes in bulk or location of the proposed development are documented and do not significantly improve the situation. A “significant” improvement would be a difference of more than 175 hours per year; and 7. The extent to which the proposed development design is consistent with advice and recommendations in the Wind Chapter Best Practice Guidance Document.

Parts of this chapter have been notified using either a Part One Schedule 1 process (**P1 Sch1**), or as part of an Intensification Planning Instrument using the Intensification Streamlined Planning Process (**ISPP**). Please see notations.

He Rohe Pokapū Paekiritata

Neighbourhood Centre Zone

NCZ	Neighbourhood Centre Zone
------------	----------------------------------

P1 Sch1

Introduction

The purpose of the Neighbourhood Centre Zone is to provide for predominantly for small-scale commercial activities and community activities that service the needs of the immediate residential neighbourhood and support the role and function of other Centre Zones in the hierarchy of centres.

The Neighbourhood Centre Zone includes a range of small commercial centres across Wellington that provide a neighbourhood function in the City's hierarchy of centres. The Neighbourhood Centre Zone is the lowest in the hierarchy due to its make-up of small spot zones for very small commercial clusters. Neighbourhood centres service the surrounding residential neighbourhood and offer small-scale convenience-based retail for day-to-day needs. These Centres tend to have easy pedestrian access for locals and have some community services and small-scale offices.

High quality building design is a focus for the Neighbourhood Centres Zone. The transition to more intensive use in some neighbourhood centres will result in changes to existing amenity values in the centres and their surrounds. Consequently, redevelopment will be supported by a range of measures to promote good design and environmental outcomes, and address amenity issues. Accordingly, most building activities will require a resource consent and an assessment against the Centres and Mixed Use Design Guide. To enable intensification around existing neighbourhood centres, some of these will have increased building heights.

There is an identified need for residential intensification within and around neighbourhood centres. Accordingly, residential activity is permitted above ground floor within these centres. To support a mix of activities within the zone, activities that have off-site effects, such as industrial activities and different retail formats, will need to be managed. There is however a desire for larger scale retail to locate in centres, where these are of an appropriate form and scale, rather than at out-of-centre locations, to support the vitality ~~and viability~~ of centres.

Development of larger sites in the Ngaio neighbourhood centre is required to be integrated and coordinated to act as a catalyst for positive change and demonstrate density done well.

Other relevant District Plan provisions

There may be a number of provisions that apply to an activity, building, structure or site. Resource consent may therefore be required under rules in this chapter as well as other chapters. Unless specifically stated in a rule, resource consent is required under each relevant rule. The steps to determine the status of an activity are set out in the General Approach chapter.

Objectives

ISPP	<p>NCZ-01</p>	<p>Purpose</p> <p>The Neighbourhood Centre Zone meets the needs of communities, businesses and residents in the immediate residential neighbourhood in a manner that supports the City's compact urban growth objectives and its role and function in the City's hierarchy of centres.</p>
ISPP	<p>NCZ-02</p>	<p>Accommodating growth</p> <p>The Neighbourhood Centre Zone has sufficient serviced, resilient development capacity <u>and additional infrastructure</u> to meet residential and commercial growth needs.</p>
ISPP	<p>NCZ-03</p>	<p>Amenity and design</p> <p>Medium <u>to high</u> density mixed-use development is achieved that positively contributes to creating a good quality, well-functioning urban environment that reflects the changing urban form and amenity values of the Neighbourhood Centres and their surrounding residential areas.</p>
P1 Sch1	<p>NCZ-04</p>	<p>Activities</p> <p>Activities will be of an appropriate scale and type to enhance the vibrancy <u>and viability</u> of Neighbourhood Centres, <u>support walkable neighbourhoods</u> and support their neighbourhood purpose.</p>
Policies		
ISPP	<p>NCZ-P1</p>	<p>Accommodating growth</p> <p>Provide for the use and development of the Neighbourhood Centre Zone to meet the City's needs for housing, business activities and community facilities, including:</p> <ol style="list-style-type: none"> 1. A variety of building types, sizes, tenures, affordability and distribution of a scale and intensity that does not undermine the <u>ongoing viability and vibrancy</u> of the Local Centre Zone and Metropolitan Centre Zone and primacy of the City Centre Zone; 2. A mix of medium <u>to high</u> density housing; 3. Convenient access to active, public transport and rapid transit options; 4. Efficient, well integrated and strategic use of available development sites; and 5. Convenient access to a range of open spaces.
P1 Sch1	<p>NCZ-P2</p>	<p>Enabled activities</p> <p>Enable a range of activities that contribute positively to the purpose of the Zone and meet the convenience needs of the immediate neighbourhood and passers-by including:</p> <ol style="list-style-type: none"> 1. Commercial activities; 2. Residential activities; 3. Community facilities;

		<ul style="list-style-type: none"> 4. Educational facilities; 5. Arts, culture and entertainment activities; 6. Emergency service facilities; 7. Community corrections activities; 8. Visitor accommodation; 9. Recreational facilities; 10. Public transport activities; and 11. Industrial activities.
P1 Sch1	NCZ-P3	<p>Managed activities</p> <p>Manage the location and scale of commercial activities which could result in cumulative adverse effects on the viability and vibrancy of centres, the retention and establishment of a mix of activities within the Neighbourhood Centre Zone, and the function of the transport network.</p>
P1 Sch1	NCZ-P4	<p>Potentially incompatible activities</p> <p>Only allow activities that are potentially incompatible with the role and function of the Neighbourhood Centre Zone, where they will not have an adverse effect on the vibrancy and amenity of the centre:</p> <ul style="list-style-type: none"> 1. Carparking visible at street edge along an active frontage or non-residential activity frontage; 2. Demolition of buildings that results in the creation of vacant land; 3. Ground floor residential activities on street edges identified as having an active frontage or non-residential activity frontage; and 4. Yard-based retail activities.
P1 Sch1	NCZ-P5	<p>Heavy industrial activities</p> <p>Avoid heavy industrial activities from locating in the Neighbourhood Centre Zone.</p>
ISPP	NCZ-P6	<p>Housing choice</p> <p>Enable medium to high density residential development that:</p> <ul style="list-style-type: none"> 1. Contributes towards accommodating anticipated growth in the City; and 2. Offers a range of housing price, type, size and tenure that is accessible to people of all ages, lifestyles, cultures, impairments and abilities.
ISPP	NCZ-P7	<p>Quality development outcomes design—neighbourhood and townscape outcomes</p> <p>Require new development, and alterations and additions to existing development at a site scale, to positively contribute to the sense of place, quality and amenity of the Neighbourhood Centre Zone by:</p> <ul style="list-style-type: none"> 1. Fulfilling the intent of the Meeting the requirements of the Centres and Mixed Use Design Guide as relevant; 2. 4-Recognising the benefits of well-designed, comprehensive development, including the extent to which the development: <ul style="list-style-type: none"> a. Acts as a positive catalyst for future change by reflecting Reflects the nature and scale of the development proposed <u>enabled</u> within

	<p>the zone and in the vicinity, and responds to the evolving, more intensive identity of the neighbourhood;</p> <p>b. Optimises the development capacity of land, particularly sites that are:</p> <ul style="list-style-type: none"> i. Large; or ii. Narrow; or iii. Vacant; or iv. Ground level parking areas; <p>c. Provides for the increased levels of residential accommodation enabled in this zone; and</p> <p>d. Provides for a range of supporting business, open space and community facilities;</p> <p>e. <u>Is accessible for emergency service vehicles.</u></p> <p>3. 2. Ensuring that the development, where relevant:</p> <ul style="list-style-type: none"> a. Responds to the site context, particularly where it is located adjacent to: <ul style="list-style-type: none"> i. A scheduled site of significance to tangata whenua or other Māori; or ii. Heritage buildings, heritage structures and heritage areas; or iii. An identified character precinct; or iv. Residential zoned areas; or v. Open space and recreation zoned areas; b. Provides a safe and comfortable pedestrian environment; c. Enhances the quality of the streetscape and public / private interface; d. Integrates with existing and planned active and public transport movement networks, including planned rapid transit stops; and e. Allows sufficient flexibility for ground floor space to be converted for a range of activities, including residential.
<p>ISPP</p>	<p>NCZ-P8 On-site residential amenity</p> <p>Achieve a good standard of amenity for residential activities in the Neighbourhood Centre Zone by:</p> <ul style="list-style-type: none"> 1. Providing residents with access to adequate outlook; and 2. Ensuring <u>convenient</u> access to convenient outdoor space, including private and/or shared communal areas <u>of outdoor space</u>; 3. <u>Fulfilling the intent of the Centres and Mixed Use Design Guide Meeting the requirements of the Residential Design Guide as relevant; and</u> 4. <u>Providing residents with adequate internal living space.</u>
<p>ISPP</p>	<p>NCZ-P9 Managing adverse effects</p> <p>Recognise the evolving, higher density development context enabled in the Neighbourhood Centre Zone, while managing any associated adverse effects including:</p> <ul style="list-style-type: none"> 1. Shading, privacy, bulk and dominance effects on adjacent sites; and 2. The impact of construction on the transport network <u>and pedestrian linkages.</u>
<p>ISPP</p>	<p>NCZ-P10 City outcomes contribution</p> <p>-</p>

	<p>Require over height, large-scale residential, non-residential and comprehensive development in the Neighbourhood Centre Zone to deliver City Outcomes Contributions as detailed and scored in <u>Appendix 16 the Centres and Mixed Use Design Guide guideline G107</u>, including through either:</p> <p>-</p> <ol style="list-style-type: none"> 1. Positively contributing to public space provision and the amenity of the site and surrounding area; and/or 2. Enabling ease of access for people of all ages and mobility; and/or 3. 2. Incorporating a level of building performance that leads to reduced carbon emissions and increased climate change resilience; and/or 4. 3. Incorporating construction materials that increase the lifespan and resilience of the development and reduce ongoing maintenance costs; and/or 5. 4. Incorporating assisted housing into the development; where this is provided, legal instruments are required to ensure that it remains assisted housing for at least 25 years; and/or 6. Enabling ease of access for people of all ages and mobility.
NCZ-P10	<p><u>Retirement villages</u></p> <p><u>Provide for retirement villages where it can be demonstrated that the development:</u></p> <ol style="list-style-type: none"> 1. <u>Fulfilling the intent of the Centres and Mixed Use Design Guide;</u> 2. <u>Includes outdoor space that is sufficient to cater for the needs of the residents of the village;</u> 3. <u>Provides an adequate and appropriately located area on site for the management, storage and collection of all waste, recycling and organic waste potentially generated by the development;</u> 4. <u>Is able to be adequately serviced by three waters infrastructure or can address any constraints on the site; and</u> 5. <u>Is of an intensity, scale and design that is consistent with the amenity values anticipated for the Zone.</u>

Rules: Land use activities

P1 Sch1	NCZ-R1	Commercial activities
	<p>1. Activity status: Permitted</p> <p>Where:</p> <p>a. The activity is not an Integrated Retail Activity (refer to Rule NCZ-R11).</p>	
P1 Sch1	NCZ-R2	Community facilities
	<p>1. Activity status: Permitted</p>	
P1 Sch1	NCZ-R3	Educational facilities
	<p>1. Activity status: Permitted</p>	
P1 Sch1	NCZ-R4	Arts, culture and entertainment activities
	<p>1. Activity status: Permitted</p>	

P1 Sch1	NCZ-R5	Emergency service facilities
	1. Activity status: Permitted	
P1 Sch1	NCZ-R6	Community corrections activities
	1. Activity status: Permitted	
P1 Sch1	NCZ-R7	Visitor accommodation
	1. Activity status: Permitted	
P1 Sch1	NCZ-R8	Recreational activities
	1. Activity status: Permitted	
P1 Sch1	NCZ-R9	Public transport activities
	1. Activity status: Permitted	
	<u>NCZ-R10</u>	<u>Retirement Villages</u>
	1. <u>Activity status: Permitted</u>	
P1 Sch1	NCZ- R1140	Residential activities
	1. Activity status: Permitted	
	Where:	
	a. The activity is located:	
	i. Above ground floor level;	
	ii. At ground floor level along any street edge not identified as an active frontage;	
	or	
	iii. At ground floor level along any street edge not identified as a non-residential activity frontage; or	
	iv. At ground level along any street not identified as requiring verandah coverage;	
	or	
	At ground level on any site contained within a Natural Hazard Overlay.	
	2. Activity status: Discretionary	
	Where:	
	a. Compliance with the requirements of NCZ- R1140 .1 cannot be achieved.	
	Notification status: An application for resource consent made in respect of rule NCZ- R1140 .2.a is precluded from being <u>limited and</u> publicly notified.	
P1 Sch1	NCZ- R1244	Integrated retail activity

	<p>1. Activity status: Permitted</p> <p>Where:</p> <p>a. The total gross floor area does not exceed 210,000m².</p>		
	<p>2. Activity status: Restricted Discretionary</p> <p>Where:</p> <p>a. Compliance with the requirements of NCZ-R1244.1.a cannot be achieved.</p> <p>Matters of discretion are:</p> <ol style="list-style-type: none"> 1. The matters in NCZ-P1, NCZ-P2, NCZ-P3, and NCZ-P4; 2. The cumulative effect of the development on: <ol style="list-style-type: none"> a. The ongoing viability and vitalitybrancy of the City Centre Zone and Golden Mile; b. The safety and efficiency of the transport network, including providing for a range of transport modes; c. The hierarchy of roads, travel demand or vehicle use; and 3. The compatibility with other activities provided for in the zone. <p>Council will not apply a permitted baseline assessment when considering the effects of integrated retail activities that cannot comply with NCZ-R11.1.a.</p>		
<p>P1 Sch1</p>	<table border="1"> <tr> <td data-bbox="288 891 518 981"> <p>NCZ-R1342</p> </td> <td data-bbox="518 891 1477 981"> <p>Industrial activities</p> </td> </tr> </table>	<p>NCZ-R1342</p>	<p>Industrial activities</p>
<p>NCZ-R1342</p>	<p>Industrial activities</p>		
	<p>1. Activity status: Permitted</p> <p>Where:</p> <p>a. The activity is not a heavy industrial activity.</p>		
	<p>2. Activity Status: Non-complying</p> <p>Where:</p> <p>a. Compliance with the requirements of NCZ-R1342.1 cannot be achieved</p> <p>Notification status: An application for resource consent made in respect of rule NCZ- R1342.2.a must be publicly notified.</p>		
<p>P1 Sch1</p>	<table border="1"> <tr> <td data-bbox="288 1518 518 1608"> <p>NCZ-R1413</p> </td> <td data-bbox="518 1518 1477 1608"> <p>Carparking activities</p> </td> </tr> </table>	<p>NCZ-R1413</p>	<p>Carparking activities</p>
<p>NCZ-R1413</p>	<p>Carparking activities</p>		
	<p>1. Activity status: Permitted</p> <p>Where:</p> <p>a. The activity involves:</p> <ol style="list-style-type: none"> i. Provision of carparks not visible at street edge along an active frontage or non-residential activity frontage; or ii. Provision of carparks above ground floor level; or iii. Provision of carparks below ground floor level; or iv. Provision of parking spaces for people with disabilities; or v. Provision of ground floor level carparks that form part of a building specifically constructed and used for carparking purposes. 		
	<p>2. Activity status: Discretionary</p>		

	Where: a. Compliance with the requirements of NCZ- R1443 .1.a is not achieved.	
P1 Sch1	NCZ- R1544	Yard-based retailing activities
	1. Activity status: Discretionary Notification status: An application for resource consent made in respect of rule LCZ- R1544 must be publicly notified, <u>except:</u> a. <u>The activity relates to the maintenance, operation and upgrading of an existing activity.</u>	
P1 Sch1	NCZ- R1645	All other activities
	1. Activity status: Discretionary Where: a. The activity is not otherwise provided for as a permitted activity, restricted discretionary activity, or a non-complying activity.	
	Rules: Building and structures activities	
ISPP	NCZ- R1746	Maintenance and repair of buildings and structures
	1. Activity status: Permitted	
ISPP	NCZ- R1847	Demolition or removal of buildings and structures
	1. Activity status: Permitted Where: a. The demolition or removal of a building: i. Is required to avoid an imminent threat to life and/or property; or ii. Enables the creation of public space or private outdoor living space associated with the use of a building; or iii. Is required for the purposes of constructing a new building or structure, or adding to or altering an existing building or structure, that <u>is a permitted activity under NCZ-R1948, or that</u> has an approved resource consent, or resource consent is being sought concurrently under NCZ-R18.2 ; or b. The building or structure for demolition or removal is not on a site that has an active frontage or non-residential activity frontage; or c. The demolition or removal involves a structure, excluding any building.	
	2. Activity status: Discretionary Where: a. Compliance with any of the requirements of NCZ- R1847 .1 cannot be achieved. The assessment of the activity must have regard to: 1. How the land will be utilised whilst it is vacant; and	

- 2. Creating a positive visual relationship between the site and streetscape whilst the site is vacant.

Notification status: An application for resource consent made in respect of rule NCZ-~~R1847~~.2.a is precluded from being either publicly or limited notified.

ISPP

NCZ-~~R1948~~ Construction of, or additions and alterations to, buildings and structures

- 1. Activity status: **Permitted**

Where:

- a. Alterations or additions to a building or structure:
 - i. Do not alter the external appearance of the building or structure; or
 - ii. Relate to a building frontage below verandah level, including entranceways and glazing and compliance with NCZ-S5 is achieved; or
 - iii. Do not result in the creation of new residential units; and
 - iv. Are not visible from public spaces; and
 - v. Comply with effects standards NCZ-S1, NCZ-S2, NCZ-S3, NCZ-S4, NCZ-S5 and NCZ-S6; and
- b. The construction of any building or structure:
 - i. Is not located on a site with an active frontage or non-residential activity frontage; or
 - ii. Is not visible from a public space; and
 - iii. Will have a gross floor area of less than 100m²; and
 - iv. Will result in a total coverage (together with other buildings) of no more than 20 percent of the site; and
 - v. Comply with effects standards NCZ-S1, NCZ-S2, NCZ-S3, NCZ-S4, NCZ-S5 and NCZ-S6; and
 - vi. Does not involve the construction of a new building for residential activities.

- 2. Activity status: **Restricted Discretionary**

Where:

- a. Compliance with any of the requirements of NCZ-~~R1948~~.1 cannot be achieved.

Matters of discretion are:

- ~~1.~~ 1. The matters in NCZ-P6, NCZ-P7, NCZ-P8, NCZ-P9 and NCZ-P10.
- ~~2.~~ 2. The extent and effect of non-compliance with any relevant standard as specified in the associated assessment criteria for the infringed standard;
- ~~3. City Outcomes Contribution as required in Appendix 16 for The Centres and Mixed-Use Design Guide, including guideline G107 – City Outcomes Contribution for any building that exceeds the maximum height requirement at Ngaio, Berhampore and Aro Valley centres; and either comprises 25 or more residential units or is a non-residential building;~~
- ~~4. The Residential Design Guide;~~
- ~~4.~~ 3. The extent and effect of any identifiable site constraints;
- ~~5.~~ 4. Construction impacts on the transport network; and
- ~~6.~~ 5. The availability and connection to existing or planned three waters infrastructure.

Notification status:

An application for resource consent made in respect of rule NCZ-~~R1948~~.2.a that complies with all standards is precluded from being either publicly or limited notified.

P1 Sch1

An application for resource consent made in respect of rule NCZ-~~R1948~~.2.a that complies with both NCZ-S3, NCZ-S7, NCZ-S8, NCZ-S9, NCZ-S10 and NCZ-S11 is precluded from being either publicly or limited notified.

An application for resource consent made in respect of rule NCZ-~~R1948~~.2.a that results from non-compliance with NCZ-S1, NCZ-S2, NCZ-S4, NCZ-S5 and NCZ-S6 is precluded from being publicly notified.

NCZ-R2019	Conversion of buildings, or parts of buildings, for residential activities
-----------------------------	---

1. Activity status: **Restricted Discretionary**

Matters of discretion are:

1. The matters in NCZ-P1, NCZ-P3, NCZ-P6, ~~and~~ NCZ-P8 ~~and~~ NCZ-P10;
2. The extent of compliance with standards NCZ-S7, NCZ-S8 and NCZ-S9 and satisfaction of associated assessment criteria; ~~and~~
- ~~3. The Residential Design Guide; and~~
4. 3. The availability and connection to existing or planned three waters infrastructure.

Notification status: An application for resource consent made in respect of rule NCZ-~~R2019~~.1 is precluded from being either publicly or limited notified.

P1 Sch1

NCZ-R2120	Outdoor storage areas
-----------------------------	------------------------------

1. Activity status: **Permitted**

Where:

1. The storage area is screened by either a fence or landscaping of 1.8m in height from any adjoining road or site; ~~and~~
2. ~~Screening does not obscure emergency or safety signage or obstruct access to emergency panels, hydrants, shut-off valves, or other emergency response facilities.~~

2. Activity status: **Restricted Discretionary**

Where:

- a. Compliance with the requirements of NCZ-~~R2120~~.1 cannot be achieved.

Matters of discretion are:

1. The matters in NCZ-P7;
2. The extent to which any lesser screening is necessary to provide for functional or operational requirements of the activities on the site, or for people’s health and safety; and
3. The extent to which outdoor storage is visible to surrounding areas, including any associated effects on amenity values where visible from Residential Zones or Open Space and Recreation Zones.

Notification status: An application for resource consent made in respect of rule NCZ- ~~R2120~~.2.a is precluded from being either publicly or limited notified.

Standards

ISPP

NCZ-S1	Maximum Height	
<p>1. The following maximum height limits above ground level must be complied with:</p>	<p>Assessment criteria where the standard is infringed:</p> <ol style="list-style-type: none"> 1. Streetscape and visual amenity effects; 2. Dominance, privacy and shading effects on adjoining sites; and 3. The extent to which taller buildings would contribute to a substantial increase in residential accommodation. 	
<p>Location</p>	<p>Height</p>	
<p>Height control area 1</p> <p>All Neighbourhood centres, including Aro Valley Centre Height Control Area A, except as stated below in Height Control Area 2</p>	<p>12 metres</p>	
<p>Height control area 2</p> <p><u>Mersey Street, Island Bay</u></p>	<p><u>14 metres</u></p>	
<p>Height control area 2-3</p> <p>Aro Valley Centre Height Control Area B Berhampore Centre Ngaio Centre Oxford Street Tawa Centre</p>	<p>22 metres</p>	
<p>2. Fences and standalone walls must not exceed a maximum height of 1.8 metres (measured above ground level).</p> <p>This standard does not apply to:</p> <ol style="list-style-type: none"> a. Accessory buildings; b. Fences or standalone walls; c. Solar panel and heating components attached to a building provided these do not exceed the height by more than 500mm; d. Satellite dishes, antennas, aerials, chimneys, flues, architectural or decorative features (e.g. finials, spires) provided that none of these exceed 1m in diameter and do not exceed the height by more than 1m; and e. Lift overruns provided these do not exceed the height by more than 4m. 		
NCZ-S2	Minimum building height	

ISPP

ISPP

<p>1. A minimum height of 7m is required for:</p> <ul style="list-style-type: none"> a. New buildings or structures; and b. Additions to the frontages of existing buildings and structures. <p><u>This standard does not apply to:</u></p> <ul style="list-style-type: none"> 1. <u>Accessory buildings, ancillary to the primary activity on the site.</u> 2. <u>Any building or structure that is unable to be occupied by people.</u> 	<p>Assessment criteria where the standard is infringed;</p> <ul style="list-style-type: none"> 1. The extent to which a reduced height: <ul style="list-style-type: none"> a. Is necessary to provide for the functional needs or operational needs of a proposed activity; 2. Whether topographical or other site constraints make compliance with the standard impracticable or unnecessary; and 3. Whether, for any additions or alterations, the existing ground floor height meets the standard.
---	--

<p>NCZ-S3</p>	<p>Minimum ground floor height</p>
----------------------	---

ISPP

<p>1. The minimum ground floor height to underside of structural slab or equivalent shall be 4m.</p>	<p>Assessment Criteria where the standard is infringed:</p> <ul style="list-style-type: none"> 1. The extent to which a reduced height: <ul style="list-style-type: none"> a. Will compromise or preclude future use or adaptation of the ground floor for non-residential activities; b. Is necessary to provide for the functional needs or operational needs of a proposed activity; and 2. Whether topographical or other site constraints make compliance with the standard impracticable or unnecessary.
--	---

<p>NCZ-S4</p>	<p>Height in relation to boundary</p>
----------------------	--

<p>1. No part of any building or structure may project beyond the relevant recession plane shown below:</p>	<p>Assessment criteria where the standard is infringed:</p> <ul style="list-style-type: none"> 1. Dominance, privacy and shading effects on adjoining sites; 2. Whether an increase in height in relation to boundary results from a response to natural hazard mitigation; 3. Effects on public spaces; and 4. The extent to which an increase
---	---

	<p>in height in relation to boundary would contribute to a substantial increase in residential accommodation.</p>
--	---

Location	Recession plane	
Boundary adjoining any site within the MRZ with a height limit of 11m identified on the District Plan Maps	60° measured from a height of 4m vertically above ground level	
Boundary adjoining any site within the MRZ with a height limit of 14m identified on the District Plan Maps	60° measured from a height of 5m vertically above ground level	
Boundary adjoining any site within the HRZ	60° measured from a height of 8m vertically above ground level	
Boundary adjoining any site within an Open Space and Recreation Zone	60° measured from a height of 5m vertically above ground level	

<p>These standards do not apply to:</p> <ul style="list-style-type: none"> a. A boundary with a road; b. Internal boundaries; c. Solar power and heating components attached to a building provided these do not exceed the height in relation to boundary by more than 500mm; and d. Satellite dishes, antennas, aerials, chimneys, flues, architectural or decorative features (e.g. finials, spires) provided that none of these exceed 1m in diameter and do not exceed the height in relation to boundary by more than 3m measured vertically. 	
---	--

ISPP

NCZ-S5	Verandah control
---------------	-------------------------

<ol style="list-style-type: none"> 1. Verandahs must be provided on building elevations on identified street frontages; 2. Any verandah must: <ol style="list-style-type: none"> a. Extend the full width of the building elevation; b. Connect with any existing adjoining verandah; c. Have a minimum clearance of 2.5m directly above the footpath or formed ground surface; d. Not exceed a maximum height of 4m measured between the base of the verandah fascia and the footpath or formed ground surface directly below; 	<p>Assessment criteria where the standard is infringed:</p> <ol style="list-style-type: none"> 1. The extent to which any non-compliance: <ol style="list-style-type: none"> a. Will adversely affect the comfort and convenience of pedestrians; b. Will result in further street trees being added to public space as part the development; and 2. The continuity of verandah coverage along the identified street, informal access route or public space.
--	---

<ul style="list-style-type: none"> e. Be setback a minimum of 450mm from any point along the kerbing extending back to the site boundary; and f. Not exceed a maximum width of 3m from the front of the building. <p>This standard does not apply to:</p> <ul style="list-style-type: none"> a. Any scheduled building identified in SCHED1-Heritage buildings. However, if for any reason these buildings received Council approval (resource consent or other approval) to be demolished, then a verandah would be required for any replacement buildings on these sites; and b. Any building where compliance with the standard results in an encroachment into the dripline of an existing street tree; <u>and</u> c. <u>Service stations.</u> 	
--	--

ISPP

NCZ-S6	Active frontage and non-residential activity frontage controls
---------------	---

<ol style="list-style-type: none"> 1. Any new building or addition to an existing building on an identified street with an active frontage must: <ul style="list-style-type: none"> a. Be built up to the street edge on all street boundaries <u>with an identified active frontage control</u> and along the full width of the site bordering any street boundary, <u>excluding vehicle and pedestrian access</u>; b. Provide a minimum of 60% of continuous display windows or transparent glazing along the width of the ground floor building frontage; and c. Locate the principal public entrance on the front boundary; <p><u>Except that this standard does not apply to service stations.</u></p> 2. Any ground level addition to, or alteration of, a building or structure facing a public space must not result in a featureless façade that: <ul style="list-style-type: none"> a. Is more than 3 metres wide; and b. Extends from a height of 1m above ground level to a maximum height of 2.5m; 3. Any roller shutter doors, security grilles, screens or similar structures fitted to the facade of any building must be at least 50% visually transparent; and 4. Any new building or addition to an existing building on a site with a non-residential activity frontage control must: <ul style="list-style-type: none"> a. Be built up to the street edge on all street boundaries and along the full width of the site bordering any street boundary; and b. Locate the principal public entrance on the front boundary. 	<p>Assessment criteria where the standard is infringed:</p> <ol style="list-style-type: none"> 1. The extent to which: <ul style="list-style-type: none"> a. Any non-compliance is required for on-site functional or operational needs; b. The building frontage is designed and located to create a strong visual alignment with adjoining buildings <u>or otherwise enhances the streetscape</u>; and c. An acceptable level of passive surveillance is maintained between the interior of the building and the street.
--	---

ISPP

NCZ-S7		Minimum residential unit size	
1. Residential units, including dual key units, must meet the following minimum sizes:		Assessment criteria where the standard is infringed: 1. The extent to which: a. The design of the proposed unit provides a good standard of amenity; and b. Other on-site factors compensate for a reduction in unit sizes.	
Residential unit type	Minimum net floor area		
a. Studio unit	35m ²		
b. 1 bedroom unit	40m ²		
c. 2+ bedroom unit	55m ²		

ISPP

NCZ-S8		Residential – outdoor living space	
<p>1. Each residential unit, including any dual key unit, must be provided with either a private outdoor living space or access to a communal outdoor living space;</p> <p>2. Where private outdoor living space is provided it must be: that is:</p> <ul style="list-style-type: none"> a. For the exclusive use of residents; b. Directly accessible from a habitable room; c. A single contiguous space; and d. Of the minimum area and dimension specified in the table below; <p>3. Where communal outdoor living space is provided it does not need to be in a single continuous space but it must be:</p> <ul style="list-style-type: none"> a. Accessible from the residential units it serves; b. Of the minimum area and dimension specified in the table below; and c. Free of buildings, parking spaces, and servicing and maneuvering <u>manoeuvring</u> areas. 		<p>Assessment criteria where the standard is infringed:</p> <p>The extent to which:</p> <ul style="list-style-type: none"> 1. Any proposed outdoor living space provides a good standard of amenity relative to the number of occupants the space is designed for; 2. Other on-site factors compensate for a reduction in the size or dimension of the outdoor living space; and 3. The availability of public space in proximity to the site. 	
Living space type	Minimum area	Minimum dimension	
a. Private			
i. Studio unit and 1-bedroom unit	5m ²	1.8m	

ii. 2+ bedroom unit	8m ²	1.8m
b. Communal		
i. For every <u>54 - 15</u> units	<u>4064</u> m ²	8m
ii. <u>For each additional unit above 15 units</u>	<u>2m²</u>	=
<u>Communal outdoor living space is calculated based on the number of units not provided with the minimum area of private outdoor living space.</u>		

ISPP

NCZ-S9	Minimum outlook space for multi-unit housing
---------------	---

1. Every residential unit must be designed to achieve a minimum of 1m by 1m outlook space for all habitable rooms.	Assessment criteria where the standard is infringed: 1. The extent to which: a. The design of the proposed unit provides a good standard of amenity; and b. Other on-site factors compensate for a reduction in outlook space.
--	---

ISPP

NCZ-S10	Minimum building separation distance
----------------	---

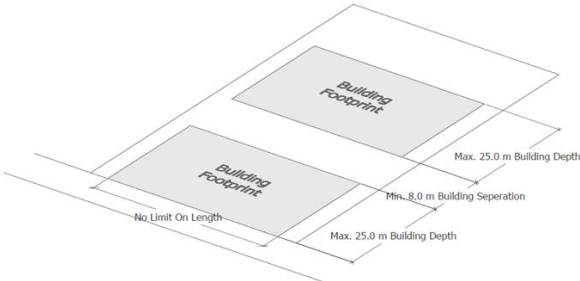
<p>1. Any new building or addition to an existing building used for residential activities must provide an 8m separation distance between buildings located on the same site, as shown in Diagram 11 below.</p>  <p>This standard does not apply to Neighbourhood centres other than Aro Valley, Berhampore and Ngaio Centres.</p>	Assessment criteria where the standard is infringed: 1. The extent to which a reduced setback will increase dominance and shadowing related effects on residential units within the development site; and 2. Dominance, privacy and shading effects on adjoining sites.
---	---

ISPP

NCZ-S11	Maximum building depth
----------------	-------------------------------

1. Any new building or additions to existing buildings used for residential activities must not result in the continuous depth of any external side wall being greater than 25m, as shown in Diagram 12 below.

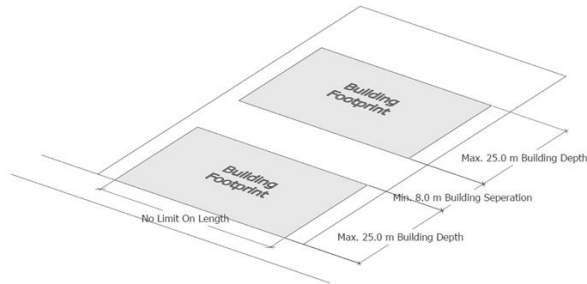

This standard does not apply to Neighbourhood centres other than Aro Valley, Berhampore and Ngaio Centres.

Assessment criteria where the standard is infringed:

1. The extent to which the design mitigates the effect of a long featureless building elevation; and
2. Dominance, privacy and shading effects on adjoining sites.

<u>Methods</u>	
<u>MCZ-M1</u>	<u>Urban Design Panel</u>
<p><u>Subject to obtaining relevant approvals and supporting funding, Council will seek to establish and facilitate an independent Urban Design Panel to inform the urban design assessments of relevant policies and matters of discretion that apply to significant resource consent applications as required.</u></p>	

Parts of this chapter have been notified using either a Part One Schedule 1 process (**P1 Sch1**), or as part of an Intensification Planning Instrument using the Intensification Streamlined Planning Process (**ISPP**). Please see notations.

He Rohe Pokapū Haukāinga

Local Centre Zone

LCZ	Local Centre Zone
------------	--------------------------

P1 Sch1

Introduction

The purpose of the Local Centre Zone is to provide for a range commercial, community, recreational and residential activities. These centres service the needs of the surrounding residential catchment and neighbouring suburbs. Local centres support the role and function of other Centre Zones in the hierarchy of centres.

The Local Centre Zone is distributed across the city and will play a crucial role in accommodating and servicing the needs of the existing and forecast population growth. The **Medium Density and High Density Residential Zone** surrounds most local centres. These zones enable intensification due to the capacity of the area to absorb more housing with enablers of growth such as walkability, access to public transport, community facilities and services.

High quality building design is a focus for the Local Centres Zone. The transition to more intensive use in some local centres will result in changes to existing amenity values in the centres and their surrounds. Consequently, redevelopment will be supported by a range of measures to promote good design and environmental outcomes, and address amenity issues. Accordingly, most building activities will require a resource consent and an assessment against the Centres and Mixed Use Design Guide. To enable intensification around existing neighbourhood centres, some of these will have substantial building heights.

There is an identified need for residential intensification within and around local centres. These centres are subject to the intensification policies 3 (c) and (d) of the National Policy Statement on Urban Development 2020 (NPS-UD). Accordingly, residential activity is permitted above ground floor within these centres. To support a mix of activities within the zone, activities that have off-site effects, such as industrial activities and different retail formats, will need to be managed. There is however a desire for larger scale retail to locate in centres, where these are of an appropriate form and scale, rather than at out-of-centre locations, to support the vitality **and viability** of centres.

Other relevant District Plan provisions

There may be a number of provisions that apply to an activity, building, structure or site. Resource consent may therefore be required under rules in this chapter as well as other chapters. Unless specifically stated in a rule, resource consent is required under each relevant rule. The steps to determine the status of an activity are set out in the General Approach chapter.

Objectives

ISPP

LCZ-01	Purpose
---------------	----------------

		The Local Centre Zone meets the needs of communities, businesses and residents in the surrounding residential catchment and neighbouring suburbs in a manner that supports the City’s compact urban growth objectives and its role and function in the City’s hierarchy of centres.
ISPP	LCZ-O2	Accommodating growth The Local Centre Zone has an important role in accommodating growth and has sufficient serviced, resilient development capacity <u>and additional infrastructure</u> to meet residential and commercial growth needs.
ISPP	LCZ-O3	Amenity and design Medium <u>to high</u> density mixed-use development is achieved that positively contributes to creating a high quality, well-functioning urban environment that reflects the changing urban form and amenity values of the Local Centres and their surrounding residential areas.
P1 Sch1	LCZ-O4	Activities Activities will be of an appropriate scale and type to enhance the vibrancy <u>and viability</u> of Local Centres, <u>support walkable neighbourhoods</u> and support their local purpose.

Policies

ISPP	LCZ-P1	Accommodating growth Provide for the use and development of the Local Centre Zone to meet the City’s needs for housing, business activities and community facilities, including: <ol style="list-style-type: none"> 1. A variety of building types, sizes, tenures, affordability and distribution of a scale and intensity that does not undermine the <u>viability and</u> vibrancy of the Metropolitan Centre Zone and the primacy of the City Centre Zone; 2. Forms of medium <u>to high</u> density housing; 3. Convenient access to active, public transport and rapid transit options; 4. Efficient, well integrated and strategic use of available development sites; and 5. Convenient access to a range of open spaces.
P1 Sch1	LCZ-P2	Enabled activities Enable a range of activities that contribute positively to the role and function of the Zone and meet the needs of the residential catchment and surrounding suburbs including: <ol style="list-style-type: none"> 1. Commercial activities; 2. Residential activities; 3. Community facilities; 4. Educational facilities;

		<p>5. Arts, culture, and entertainment activities; 6. Emergency service facilities; 7. Community corrections activities; 8. Visitor accommodation; 9. Recreational facilities; 10. Public transport activities; and 11. Industrial activities.</p>
P1 Sch1	LCZ-P3	<p>Managed activities</p> <p>Manage the location and scale of commercial activities which could result in cumulative adverse effects on the viability and vibrancy of centres, the retention and establishment of a mix of activities within the Local Centre Zone, and the function of the transport network.</p>
P1 Sch1	LCZ-P4	<p>Potentially incompatible activities</p> <p>Only allow activities that are potentially incompatible with the role and function of the Local Centre Zone, where they will not have an adverse effect on the vibrancy and amenity of the centre:</p> <ol style="list-style-type: none"> 1. Carparking visible at street edge along an active frontage or non-residential activity frontage; 2. Demolition of buildings that results in the creation of unutilised vacant land; 3. Ground floor residential activities on street edges identified as having an active frontage or non-residential activity frontage; and 4. Yard-based retail activities.
P1 Sch1	LCZ-P5	<p>Heavy industrial activities</p> <p>Avoid heavy industrial activities from locating in the Local Centre Zone.</p>
ISPP	LCZ-P6	<p>Housing choice</p> <p>Enable medium density residential development that:</p> <ol style="list-style-type: none"> 1. Contributes towards accommodating anticipated growth in the City; and 2. Offers a range of housing price, type, size and tenure that is accessible to people of all ages, lifestyles, cultures, impairments and abilities.
ISPP	LCZ-P7	<p>Quality development design outcomes –neighbourhood and townscape outcome</p> <p>Require new development, and alterations and additions to existing development at a site scale, to positively contribute to the sense of place, quality and amenity of the Local Centre Zone by:</p> <ol style="list-style-type: none"> 1. Meeting the requirements-Fulfilling the intent of the Centres and Mixed Use Design Guide as relevant; 2. 4. Recognising the benefits of well-designed, comprehensive development, including the extent to which the development: <ol style="list-style-type: none"> a. Acts as a positive catalyst for future change by reflectingReflects the nature and scale of the development proposedenabled within

	<p>the zone and in the vicinity and responds to the evolving, more intensive identity of the neighbourhood;</p> <p>b. Optimises the development capacity of land and particularly sites that are:</p> <ul style="list-style-type: none"> i. Large; or ii. Narrow; or iii. Vacant; or iv. Ground level parking areas; <p>c. Provides for the increased levels of residential accommodation enabled in this zone; and</p> <p>d. Provides for a range of supporting business, open space and community facilities; and</p> <p>e. <u>Is accessible for emergency service vehicles.</u></p> <p>3. 2. Ensuring that the development, where relevant:</p> <ul style="list-style-type: none"> a. Responds to the site context, particularly where it is located adjacent to: <ul style="list-style-type: none"> i. A scheduled site of significance to tangata whenua or other Māori; ii. Heritage buildings, heritage structures and heritage areas; iii. An identified character precinct; iv. Residential zoned areas; v. Open space zoned areas; b. Provides a safe and comfortable pedestrian environment; c. Enhances the quality of the streetscape and public / private interface; d. Integrates with existing and planned active and public transport movement networks, including planned rapid transit stops; and e. Allows sufficient flexibility for ground floor space to be converted for a range of activities, including residential.
<p>ISPP</p>	<p>LCZ-P8 On-site residential amenity</p> <p>Achieve a good standard of amenity for residential activities in the Local Centre Zone by:</p> <ul style="list-style-type: none"> 1. Providing residents with access to adequate outlook; and 2. Ensuring <u>convenient</u> access to convenient outdoor space, including private and/or shared communal areas <u>of outdoor space;</u> 3. Meeting the requirements<u>Fulfilling the intent of the Residential Centres and Mixed Use Design Guide as relevant; and</u> 4. <u>Providing residents with adequate internal living space.</u>
<p>ISPP</p>	<p>LCZ-P9 Managing adverse effects</p> <p>Recognise the evolving, higher density development context enabled in the Local Centres Zone, while managing any associated adverse effects including:</p> <ul style="list-style-type: none"> 1. Shading, privacy, bulk and dominance effects on adjacent sites; and 2. The impact of construction on the transport network <u>and pedestrian linkages.</u>
<p>ISPP</p>	<p>LCZ-P10 City outcomes contribution</p> <p>Require over height, large-scale residential, non-residential and comprehensive development in the Local Centre Zone to deliver City</p>

	<p>Outcomes Contributions as detailed and scored in <u>Appendix 16 the Centres and Mixed Use Design Guide guideline G107</u>, including through either <u>satisfying at least two of the following outcomes</u>:</p> <ol style="list-style-type: none"> 1. Positively contributing to public space provision and the amenity of the site and surrounding area; and/or 2. <u>Enabling universal accessibility within buildings ease of access for people of all ages and mobility; and/or</u> 3. <u>3.</u> Incorporating a level of building performance that leads to reduced carbon emissions and increased <u>earthquake climate change</u> resilience; and/or 3. <u>4.</u> Incorporating construction materials that increase the lifespan and resilience of the development and reduce ongoing maintenance costs; and/or 4. <u>5.</u> Incorporating assisted housing into the development; where this is provided, legal instruments are required to ensure that it remains assisted housing for at least 25 years; and/or 5. <u>Enabling ease of access for people of all ages and mobility.</u>
--	---

<u>LCZ-P11</u>	<p><u>Retirement villages</u></p> <p><u>Provide for retirement villages where it can be demonstrated that the development:</u></p> <ol style="list-style-type: none"> 1. <u>Fulfil the intent of the Centres and Mixed Use Design Guide;</u> 2. <u>Includes outdoor space that is sufficient to cater for the needs of the village;</u> 3. <u>Provides an adequate and appropriately located area on site for the management, storage and collection of all of the solid waste, recycling and organic waste potentially generated by the development;</u> 4. <u>Is able to be adequately serviced by three waters infrastructure or can address any constraints on the site; and</u> 5. <u>Is of an intensity, scale and design that is consistent with the amenity values anticipated in the Zone.</u>
-----------------------	---

Rules: Land use activities

P1 Sch1

LCZ-R1	Commercial activities
---------------	------------------------------

<ol style="list-style-type: none"> 1. Activity status: Permitted Where: <ol style="list-style-type: none"> a. The activity is not an Integrated Retail Activity (refer to Rule LCZ-<u>R1244</u>).

P1 Sch1

LCZ-R2	Community facilities
---------------	-----------------------------

<ol style="list-style-type: none"> 1. Activity status: Permitted
--

P1 Sch1

LCZ-R3	Educational facilities
---------------	-------------------------------

<ol style="list-style-type: none"> 1. Activity status: Permitted
--

P1 Sch1

LCZ-R4	Arts, culture and entertainment activities
---------------	---

<ol style="list-style-type: none"> 1. Activity status: Permitted
--

P1 Sch1	LCZ-R5	Emergency services facilities
	1. Activity status: Permitted	
P1 Sch1	LCZ-R6	Community corrections activities
	1. Activity status: Permitted	
P1 Sch1	LCZ-R7	Visitor accommodation
	1. Activity status: Permitted	
P1 Sch1	LCZ-R8	Recreational activities
	1. Activity status: Permitted	
P1 Sch1	LCZ-R9	Public transport activities
	1. Activity status: Permitted	
P1 Sch1	<u>LCZ-R10</u>	<u>Retirement Villages</u>
	1. <u>Activity status: Permitted</u>	
P1 Sch1	LCZ-R1140	Residential activities
	1. Activity status: Permitted	
	Where:	
	a. The activity is located: <ul style="list-style-type: none"> i. Above ground floor level; ii. At ground floor level along any street edge not identified as an active frontage; iii. At ground floor level along any street edge not identified as a non-residential activity frontage; iv. At ground level along any street not identified as requiring verandah coverage; or v. At ground level on any site contained within a Natural Hazard Overlay. 	
	2. Activity status: Discretionary	
Where:		
a. Compliance with the requirements of LCZ-R10.1.a cannot be achieved.		
Notification status: An application for resource consent made in respect of rule LCZ-R10.2.a is precluded from being limited and publicly notified.		
2. Activity status: Restricted Discretionary		
Where:		

P1 Sch1

<p><u>a. Compliance with the requirements of LCZ-R11.1.a cannot be achieved.</u></p> <p><u>Matters of discretion are:</u></p> <ol style="list-style-type: none"> <u>1. The matters in LCZ-P4, LCZ-P6 and LCZ-P7;</u> <u>2. The extent and effect of non-compliance with LCZ-S5 and LCZ-S6;</u> <u>3. Whether residential activities exceed 50% of the street frontage at ground floor;</u> <u>4. The extent to which an acceptable level of passive surveillance is maintained between the interior of the building and the street or area of public space;</u> <u>5. The extent to which the building frontage is designed and located to create a strong visual alignment with adjoining buildings;</u> <u>6. The effect on the visual quality of the streetscape and the extent to which the activity contributes to or detracts from the surrounding public space;</u> <u>7. The continuity of verandah coverage along the identified street, informal access route or public space; and</u> <u>8. The extent to which non-compliance with verandah coverage will adversely affect the comfort and convenience of pedestrians.</u> <p><u>Notification status: An application for resource consent made in respect of rule LCZ-R11.2.a is precluded from being either publicly or limited notified.</u></p>
--

LCZ-R1244

Integrated retail activity

<p>1. Activity status: Permitted</p> <p>Where:</p> <p style="padding-left: 40px;">a. The total gross floor area does not exceed 20,000m².</p>
<p>2. Activity status: Restricted Discretionary</p> <p>Where:</p> <p style="padding-left: 40px;">a. Compliance with the requirements of LCZ-R1244.1 cannot be achieved.</p> <p>Matters of discretion are:</p> <ol style="list-style-type: none"> 1. The matters in LCZ-P1, LCZ-P2, LCZ-P3, and LCZ-P4; 2. The cumulative effect of the development on: <ol style="list-style-type: none"> a. The viability and vitality of the City Centre Zone and Golden Mile; b. The safety and efficiency of the transport network, including providing for a range of transport modes; c. The hierarchy of roads, travel demand or vehicle use; and 3. The compatibility with other activities provided for in the zone. <p>Council will not apply a permitted baseline assessment when considering the effects of integrated retail activities that cannot comply with LCZ-R11.1.a.</p>

P1 Sch1

LCZ-R1342

Industrial activities

<p>1. Activity status: Permitted</p> <p>Where:</p> <p style="padding-left: 40px;">a. The activity is not a heavy industrial activity.</p>
--

	<p>2. Activity Status: Non-complying</p> <p>Where:</p> <p>a. Compliance with the requirements of LCZ-R1342.1.a cannot be achieved.</p> <p>Notification status: An application for resource consent made in respect of rule LCZ-R1342.2.a must be publicly notified.</p>	
P1 Sch1	LCZ-R1443	Carparking activities
	<p>1. Activity status: Permitted</p> <p>Where:</p> <p>a. The activity involves:</p> <ul style="list-style-type: none"> i. Provision of carparks not visible at street edge along an active frontage or non-residential activity frontage; ii. Provision of carparks above ground floor level; iii. Provision of carparks below ground floor level; iv. Provision of parking spaces for people with disabilities; or v. Provision of ground floor level carparks that form part of a building specifically constructed and used for carparking purposes-; <u>or</u> <u>vi. Provision of carparks on a road.</u> 	
	<p>2. Activity status: Discretionary</p> <p>Where:</p> <p>a. Compliance with the requirements of LCZ-R1443.1.a is not achieved.</p>	
P1 Sch1	LCZ-R1544	Yard-based retailing activities
	<p>1. Activity status: Discretionary</p> <p>Notification status: An application for resource consent made in respect of rule LCZ-R1544 <u>that is either a new activity or expands the net area of an existing activity</u> must be publicly notified. <u>except when:-</u></p> <p>a. <u>The activity relates to the maintenance, operation and upgrading of an existing activity</u></p>	
P1 Sch1	LCZ-R1645	All other activities
	<p>1. Activity status: Discretionary</p> <p>Where:</p> <p>a. The activity is not otherwise provided for as a permitted activity, restricted discretionary activity, or a non-complying activity.</p>	
	Rules: Building and structures activities	
ISPP	LCZ-R1746	Maintenance and repair of buildings and structures
	<p>1. Activity status: Permitted</p>	

ISPP

LCZ-R1847

Demolition or removal of buildings and structures

1. Activity status: **Permitted**

Where:

- a. The demolition or removal of a building:
 - i. Is required to avoid a threat to life and/or property;
 - ii. Enables the creation of public space or private outdoor living space associated with the use of a building;
 - iii. Is required for the purposes of constructing a new building or structure, or adding to or altering an existing building or structure, that is a permitted activity under LCZ-R1948, or that has an approved resource consent, or resource consent is being sought concurrently ~~under LCZ-R18.2~~; or
- b. The building or structure for demolition or removal is not on a site that has an active frontage or non-residential activity frontage; or
- c. The demolition or removal involves a structure, excluding any building.

2. Activity status: **Discretionary**

Where:

- a. Compliance with any of the requirements of LCZ-R1847.1 cannot be achieved.

The assessment of the activity must have regard to:

- 1. How the land will be utilised whilst it is vacant; and
- 2. Creating a positive visual relationship between the site and streetscape whilst the site is vacant.

Notification status: An application for resource consent made in respect of rule LCZ-R1847.2.a is precluded from being either publicly or limited notified.

ISPP

LCZ-R1948

Construction of, or additions and alterations to, buildings and structures

1. Activity status: **Permitted**

Where:

- a. ~~The Any~~ alterations or additions to a building or structure ~~that~~:
 - i. Do not alter ~~its the~~ external appearance ~~of the building or structure~~; or
 - ii. Involve the placement of solar panels on rooftops; or
 - iii. Involve maintenance, repair or painting; or
 - iv. Involve re-cladding with like for like materials and colours; or
 - v. Relate to a building frontage that is:
 - Below verandah level, including entranceways and glazing; and
 - Compliant compliance with LCZ-S5 is achieved; or
 - vi. Are not visible from public spaces; and
- b. The alterations or additions:
 - i. ~~Do not~~ result in the creation of new residential units; and
 - ii. Comply with standards LCZ-S1, LCZ-S2, LCZ-S3, LCZ-S4, LCZ-S5 and LCZ-S6; and
- c. The construction of any building or structure:
 - i. Is not located on a site with an active frontage or non-residential activity frontage; or
 - ii. Is not visible from a public space; and

	<ul style="list-style-type: none"> iii. Will have a gross floor area of less than 100m²; and iv. Will result in a total coverage (together with other buildings) of no more than 20 percent of the site; and v. Will comply <u>Comply</u> with effects standards LCZ-S1, LCZ-S2, LCZ-S3, LCZ-S4, LCZ-S5 and LCZ-S6; and vi. Does not involve the construction of a new building for residential activities.
	<p>2. Activity status: Restricted Discretionary</p> <p>Where:</p> <ul style="list-style-type: none"> a. Compliance with any of the requirements of LCZ-R1948.1 cannot be achieved. <p>Matters of discretion are:</p> <ul style="list-style-type: none"> 1. The matters in LCZ-P6, LCZ-P7, LCZ-P8, LCZ-P9, and LCZ-P10 <u>and LCZ-P11</u>; 2. The extent and effect of non-compliance with LCZ-S1, LCZ-S2, LCZ-S3, LCZ-S4, LCZ-S5, LCZ-S6, LCZ-S7, LCZ-S8, LCZ-S9, LCZ-S10, and LCZ-S11 <u>and LCZ-S12</u>; 3. City Outcomes Contribution as required in Appendix 16 The Centres and Mixed-Use Design Guide, including guideline G107 – City Outcomes Contribution for any building that exceeds the maximum height requirement and either comprises 25 or more residential units or is a non-residential building; 4. The Residential Design Guide; 3. The extent and effect of any identifiable site constraints; 4. Construction impacts on the transport network; and 5. The availability and connection to existing or planned three waters infrastructure. <p>Notification status:</p> <p><u>An application for resource consent made in respect of rule LCZ- R1948.2.a that complies with all standards is precluded from being either publicly or limited notified.</u></p> <p>An application for resource consent made in respect of rule LCZ- R1948.2.a that complies with LCZ-S3, LCZ-S7, LCZ-S8, LCZ-S9, LCZ-S10 and LCZ-S11 is precluded from being either publicly or limited notified.</p> <p>An application for resource consent made in respect of rule LCZ- R1948.2.a that results from non-compliance with LCZ-S1, LCZ-S2, LCZ-S4, LCZ-S5 and LCZ-S6 is precluded from being publicly notified.</p>
	<p>3. <u>Activity status: Restricted Discretionary</u></p> <p><u>Where:</u></p> <ul style="list-style-type: none"> a. <u>In addition to LCZ- R1948.2, and as it relates to the construction of, or addition to, a building or structure, the relevant building height at LCZ-S1 is exceeded by more than 25%.</u> <p><u>Matters of discretion are:</u></p> <ul style="list-style-type: none"> 1. <u>The matters in LCZ-P10;</u> 2. <u>The application and implementation of the City Outcome Contribution as set out in Appendix 16.</u> <p><u>Notification status: An application for resource consent made in respect of rule LCZ- R19.3 is precluded from being either publicly or limited notified, except where the application does not satisfy the outcome threshold in LCZ-P10.</u></p>

P1 Sch1

LCZ-R2049	Conversion of buildings, or parts of buildings, for residential activities
------------------	---

	<p>2. Activity status: Restricted Discretionary</p> <p>Matters of discretion are:</p> <ol style="list-style-type: none"> 1. The matters in LCZ-P1, LCZ-P3, LCZ-P6, and LCZ-P8 and LCZ-P11; 2. The extent of compliance with standards LCZ-S7, LCZ-P8 and LCZ-S9 and satisfaction of associated assessment criteria; and 3. The Residential Design Guide; and 4. 3. The availability and connection to existing or planned three waters infrastructure. <p>Notification status: An application for resource consent made in respect of rule LCZ-R2049.1 is precluded from being either publicly or limited notified.</p>
--	--

P1 Sch1

LCZ-R2120	Outdoor storage areas
------------------	------------------------------

	<p>1. Activity status: Permitted</p> <p>Where:</p> <ol style="list-style-type: none"> a. The storage area is screened by either a fence or landscaping of 1.8m in height from any adjoining road or site. b. <u>Screening does not obscure emergency or safety signage or obstruct access to emergency panels, hydrants, shut-off valves, or other emergency response facilities.</u>
--	--

	<p>2. Activity status: Restricted Discretionary</p> <p>Where:</p> <ol style="list-style-type: none"> a. Compliance with the requirements of LCZ-R2120.1 cannot be achieved. <p>Matters of discretion are:</p> <ol style="list-style-type: none"> 1. The matters in LCZ-P7; 2. The extent to which any lesser screening is necessary to provide for the functional needs or operational needs of the activities on the site, or for people's health and safety; and 3. The extent to which outdoor storage is visible to surrounding areas, including any associated effects on amenity values where visible from Residential or Open Space Zones. <p>Notification status: An application for resource consent made in respect of rule LCZ- R2120.2.a is precluded from being either publicly or limited notified.</p>
--	--

Standards

ISPP

LCZ-S1	Maximum height
---------------	-----------------------

<p>1. The following maximum height limits above ground level must be complied with:</p>	<p>Assessment criteria where the standard is infringed:</p> <ol style="list-style-type: none"> 1. Streetscape and visual amenity effects; 2. Dominance, privacy and shading effects on adjoining sites; and 3. The extent to which taller buildings would contribute to a substantial increase in residential accommodation.
---	---

Location	Limit	
<p>Height Control Area 1</p> <p>Newtown Local Centre Heritage Area Island Bay Local Centre Heritage Area Hataitai Local Centre Heritage Area</p>	<p>12 metres</p>	
<p>Height Control Area 2</p> <p>Karori Kelburn Khandallah Newtown Local Centre Heritage Area</p>	<p>18 metres</p>	
<p>Height Control Area 3</p> <p>Brooklyn Churton Park Crofton Downs Island Bay Kelburn Khandallah Linden Hataitai Miramar Newlands Newtown Tawa</p>	<p>22 metres</p>	
<p><u>Height Control Area 4</u></p> <p><u>Newtown</u> <u>Tawa</u></p>	<p><u>27 metres</u></p>	
<p>2. Fences and standalone walls must not exceed a maximum height of 1.8 metres (measured above ground level).</p> <p>This standard does not apply to:</p> <ul style="list-style-type: none"> a. Accessory buildings. b. Solar panel and heating components attached to a building provided these do not 		

	<p>exceed the height by more than 500mm;</p> <p>c. Satellite dishes, antennas, aerials, chimneys, flues, architectural or decorative features (e.g. finials, spires) provided that none of these exceed 1m in diameter and do not exceed the height by more than 1m; and</p> <p>d. Lift overruns provided these do not exceed the height by more than 4m.</p>	
ISPP	LCZ-S2	Minimum building height
	<p>1. A minimum height of 7m is required for:</p> <p>a. New buildings or structures; and</p> <p>b. Additions to the frontages of existing buildings and structures.</p> <p><u>This standard does not apply to:</u></p> <p>1. <u>Accessory buildings, ancillary to the primary activity on the site.</u></p> <p>2. <u>Any building or structure that is unable to be occupied by people.</u></p>	<p>Assessment criteria where the standard is infringed;</p> <p>1. The extent to which a reduced height:</p> <p>a. Is necessary to provide for the functional needs or operational needs of a proposed activity;</p> <p>2. Whether topographical or other site constraints make compliance with the standard impracticable or unnecessary; and</p> <p>3. Whether, for any additions or alterations, the existing ground floor height meets the standard.</p>
ISPP	LCZ-S3	Minimum ground floor height
	<p>1. The minimum ground floor height to <u>the</u> underside of <u>a</u> structural slab or equivalent shall be 4m.</p>	<p>Assessment criteria where the standard is infringed:</p> <p>1. The extent to which a reduced height:</p> <p>a. Will compromise or preclude future use or adaptation of the ground floor for non-residential activities;</p> <p>b. Is necessary to provide for the functional needs or operational needs of a proposed activity; and</p> <p>2. Whether topographical or other site constraints make compliance with the standard impracticable or unnecessary.</p>
ISPP	LCZ-S4	Height in relation to boundary
	<p>1. No part of any building or structure may project beyond the relevant recession plane shown below:</p>	<p>Assessment criteria where the standard is infringed:</p>

		<ol style="list-style-type: none"> 1. Dominance, privacy, and shading effects on adjoining sites; 2. Whether an increase in height in relation to boundary results from a response to natural hazard mitigation; 3. Effects on public spaces; and 4. The extent to which an increase in height in relation to boundary would contribute to a substantial increase in residential accommodation.
Location	Recession plane	
Boundary adjoining any site within the MRZ with a height limit of 11m identified on the District Plan Maps	60° measured from a height of 4m vertically above ground level	
Boundary adjoining any site within the MRZ with a height limit of 14m identified on the District Plan Maps	60° measured from a height of 5m vertically above ground level	
Boundary adjoining any site within the HRZ	60° measured from a height of 8m vertically above ground level	
Boundary adjoining any site within an Open Space Zone	60° measured from a height of 5m vertically above ground level	
<p>These standards do not apply to:</p> <ol style="list-style-type: none"> a. A boundary with a road. b. Internal boundaries; c. Solar power and heating components attached to a building provided these do not exceed the height in relation to boundary by more than 500mm; and d. Satellite dishes, antennas, aerials, chimneys, flues, architectural or decorative features (e.g. finials, spires) provided that none of these exceed 1m in diameter and do not exceed the height in relation to boundary by more than 3m measured vertically. 		
<p>LCZ-S5 Verandah control</p>		
<ol style="list-style-type: none"> 1. Verandahs must be provided on building elevations on identified street frontages; 2. Any verandah must: <ol style="list-style-type: none"> a. Extend the full width of the building elevation; b. Connect with any existing adjoining verandah; c. Have a minimum clearance of 2.5m directly above the footpath or formed ground surface; 		<p>Assessment criteria where the standard is infringed:</p> <ol style="list-style-type: none"> 1. The extent to which any non-compliance: <ol style="list-style-type: none"> a. Will adversely affect the comfort and convenience of pedestrians;

ISPP

<p>d. Not exceed a maximum height of 4m measured between the base of the verandah fascia and the footpath or formed ground surface directly below;</p> <p>e. Be setback a minimum of 450mm from any point along the kerbing extending back to the site boundary; and</p> <p>f. Not exceed a maximum width of 3m from the front of the building.</p> <p>This standard does not apply to:</p> <p>a. Any scheduled building identified in SCHED1- Heritage buildings. However, if for any reason these buildings received Council approval (resource consent or other approval) to be demolished, then a verandah would be required for any replacement buildings on these sites; and</p> <p>b. Any building where compliance with the standard results in an encroachment into the dripline of an existing street tree. ; and</p> <p>c. <u>Service stations.</u></p>	<p>b. Will result in further street trees being added to public space as part the development; and</p> <p>2. The continuity of verandah coverage along the identified street, informal access route or public space.</p>
---	--

ISPP

LCZ-S6	Active frontage and non-residential activity frontage controls
---------------	---

<p>1. Any new building or addition to an existing building facing adjoining an identified street with an active frontage must:</p> <p>a. Be built up to the street edge <u>at ground floor level along at least 90% of the full width of the site that borders the street(s); on all street boundaries with an identified active frontage control and along the full width of the site bordering any street boundary, excluding vehicle and pedestrian access;</u></p> <p>b. Provide a minimum of 60% of continuous display windows or transparent glazing along the width of the ground floor building frontage; and</p> <p>c. Locate the principal public entrance on the front boundary.</p> <p><u>This standard does not apply to:</u></p> <p>a. <u>Any vehicle and pedestrian access to a site situated on a street subject to an active frontage or non-residential activity control;</u></p> <p>b. <u>Service stations.</u></p> <p>Except that this does not apply to service stations.</p> <p>2. Any ground level addition to, or alteration of, a building or structure facing a public space must not result in a featureless façade that:</p> <p>a. Is more than 3 metres wide; and</p> <p>b. Extends from a height of 1m above ground level to a maximum height of 2.5m;</p> <p>3. Any roller shutter doors, security grilles, screens or similar structures fitted to the facade of any building</p>	<p>Assessment criteria where the standard is infringed:</p> <p>1. The extent to which:</p> <p>a. Any non-compliance is required for on-site functional needs or operational needs;</p> <p>b. The building frontage is designed and located to create a strong visual alignment with adjoining buildings <u>or otherwise enhances the streetscape;</u> and</p> <p>c. An acceptable level of passive surveillance is maintained between the interior of the building and the street.</p>
---	--

<p>must be at least 50% visually transparent; and</p> <p>4. Any new building or addition to an existing building on a site with a non-residential activity frontage control must:</p> <ul style="list-style-type: none"> a. Be built up to the street edge on all street boundaries and along the full width of the site bordering any street boundary; and b. Locate the principal public entrance on the front boundary. 	
--	--

ISPP

LCZ-S7	Minimum residential unit size
---------------	--------------------------------------

<p>2. Residential units, including dual key units must meet the following minimum sizes:</p>	<p>Assessment criteria where the standard is infringed:</p> <ul style="list-style-type: none"> 1. The extent to which: <ul style="list-style-type: none"> a. The design of the proposed unit provides a good standard of amenity; and b. Other on-site factors compensate for a reduction in unit sizes.
--	--

Residential unit type	Minimum net floor area
a. Studio unit	35m ²
b. 1 bedroom unit	40m ²
c. 2+ bedroom unit	55m ²

ISPP

LCZ-S8	Residential – outdoor living space
---------------	---

<ul style="list-style-type: none"> 1. Each residential unit, including any dual key unit, must be provided with either a private outdoor living space or access to a communal outdoor living space. 2. Where private outdoor living space is provided it must be: <ul style="list-style-type: none"> a. For the exclusive use of residents; b. Directly accessible from a habitable room; c. A single contiguous space; and d. Of the minimum area and dimension specified in the table below; and 3. Where communal outdoor living space is provided it does not need to be in a single continuous space but it must be: <ul style="list-style-type: none"> a. Accessible from the residential units it serves; b. Of the minimum area and dimension specified in the table below; and 	<p>Assessment criteria where the standard is infringed:</p> <ul style="list-style-type: none"> 1. The extent to which: <ul style="list-style-type: none"> a. The size of the proposed outdoor living space provides a good standard of amenity relative to the number of occupants the space is designed for; and b. Other on-site factors compensate for a reduction in the size of the outdoor living space (e.g. communal living space); 2. Whether any alternative publicly available open space adjoins or is in close proximity to the site; and
--	---

c. Free of buildings, parking spaces, and servicing and maneuvering <u>manoeuvring</u> areas.		3. Whether topographical or other site constraints make compliance with the standard impracticable.
Living space type	Minimum area	Minimum dimension
a. Private		
i. Studio unit and 1-bedroom unit	5m ²	1.8m
iii. 2+ bedroom unit	8m ²	1.8m
a. Communal		
i. For every 5 4 – 15 units	4064 m ²	8m
ii. <u>For each additional unit above 15 units</u>	<u>2</u> m ²	=
<u>Note: Communal outdoor living space is calculated on the basis of the number of units without exclusive access to based on the number of units not provided with the minimum area of private outdoor living space.</u>		

ISPP

LCZ-S9	Minimum outlook space for multi-unit housing
---------------	---

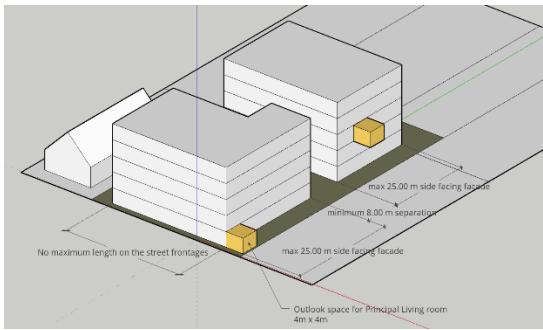
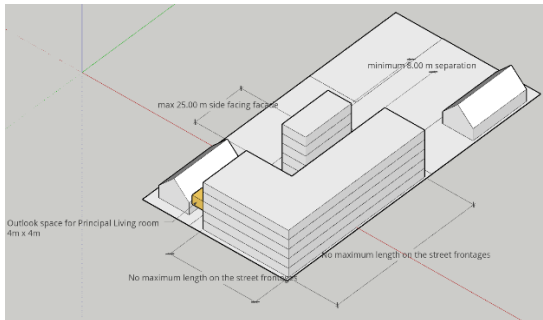
<ol style="list-style-type: none"> Every residential unit must be designed to achieve a minimum of 1m by 1m outlook space for all habitable rooms. <u>All principal living rooms must have an outlook space of a minimum dimension of 4m in depth and 4m in width as shown in Diagram X and Diagram X below.</u> 	<p>Assessment criteria where the standard is infringed:</p> <ol style="list-style-type: none"> The extent to which: <ol style="list-style-type: none"> The design of the proposed unit provides a good standard of amenity; and Other on-site factors compensate for a reduction in outlook space.
	
	

ISPP

LCZ-S10	Minimum building separation distance <u>for residential activities</u>
----------------	---

1. Any new residential building or addition to an existing residential building must provide an 8m separation distance between buildings located on the same site, as shown Diagram 13 and Diagram X below.

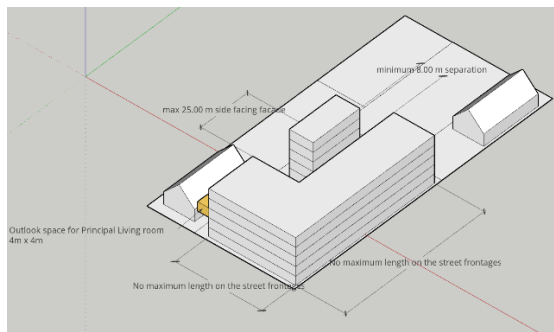
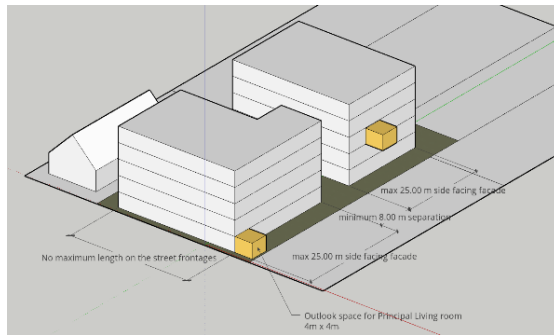
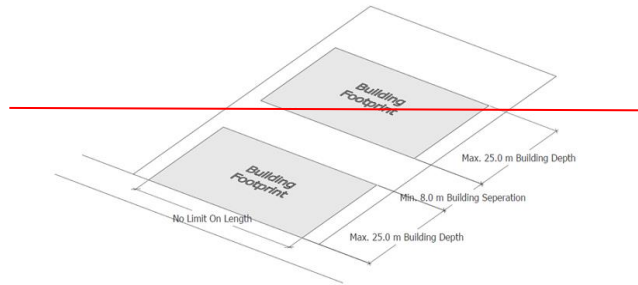

Assessment criteria where the standard is infringed:

1. The extent to which a reduced setback will increase dominance and shadowing related effects on residential units within the development site; and
2. Dominance, privacy and shading effects on adjoining sites.

ISPP

LCZ-S11	Maximum building depth <u>for residential activities</u>
----------------	---

~~1. Any new building or additions to existing buildings used for residential activities must not result in the continuous depth of any external side wall being greater than 25m, as shown in Diagram 14 below.~~

1. Any new building, part of a new building, or additions to an existing building, constructed for residential activities on any site aside from a rear site, must not result in the continuous length of any external side façade, facing a neighbouring site, being greater than 25m, as shown in Diagram 19 and Diagram X below.

Assessment criteria where the standard is infringed:

1. The extent to which the design mitigates the effect of a long features building elevations; and
2. Dominance, privacy and shading effects on adjoining sites.

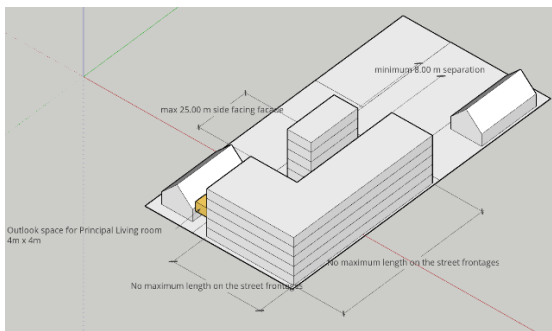
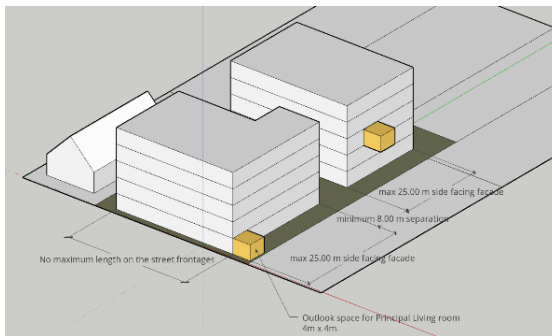
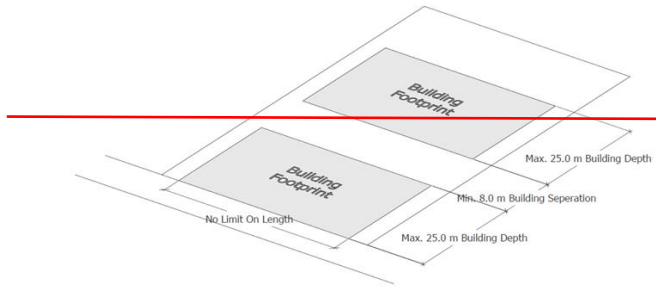

ISPP

<u>LCZ-S12</u>	<u>Boundary setback from a rail corridor</u>
<p>1. <u>Buildings or structures must not be located within 1.5m of the boundary of a designated rail corridor.</u></p>	<p><u>Assessment criteria where the standard is infringed:</u></p> <p>1. <u>The extent to which the location and design of the building relates to the ability to safely use, access and maintain buildings without requiring access on, above or over the rail corridor.</u></p>

Methods

<u>LCZ-M1</u>	<u>Urban Design Panel</u>
<p><u>Subject to obtaining relevant approvals and supporting funding, Council will seek to establish and facilitate an independent Urban Design Panel to inform the urban design assessments of relevant policies and matters of discretion that apply to significant resource consent applications as required.</u></p>	

This entire chapter has been notified using the RMA Part One, Schedule 1 process ([P1 Sch1](#)).

He Rohe Arumoni

Commercial Zone

COMZ	Commercial Zone
-------------	------------------------

Introduction

The purpose of the Commercial Zone is to provide for a mixture of commercial and residential activities.

The Commercial Zone applies to an area of land on Curtis Street in Karori and supports the City's hierarchy of centres.

Development in the Commercial Zone needs to be of a nature and scale that supports the social, cultural and economic importance of the City Centre and other Centres. It is vital that the City Centre remains the economic and employment hub for the region and that the Metropolitan, Local and Neighbourhood Centres are vibrant and well-functioning. Accordingly, the Commercial Zone does not anticipate large supermarkets or integrated retail activity, which is more appropriately located in the Metropolitan Centre Zone, Local Centre Zone, Neighbourhood Centre Zone or City Centre Zone.

Development is supported by a range of measures to ensure good design, environmental outcomes and address amenity effects.

Other relevant District Plan provisions

There may be a number of provisions that apply to an activity, building, structure or site. Resource consent may therefore be required under rules in this chapter as well as other chapters. Unless specifically stated in a rule, resource consent is required under each relevant rule. The steps to determine the status of an activity are set out in the General Approach chapter.

Objectives	
COMZ-01	<p>Purpose</p> <p>The Commercial Zone contributes to meeting the City's needs for business land and supports the hierarchy of centres.</p>
COMZ-02	<p>Activities</p> <p>Activities and development will be of an appropriate scale and type that do not undermine the vibrancy and viability of the Neighbourhood Centre Zone, Local Centre Zone, and Metropolitan Centre Zone and the primacy of the City Centre Zone.</p>
COMZ-03	<p>Amenity and design</p>

Development in the Commercial Zone is achieved that positively contributes to creating a good quality, well-functioning urban environment and is compatible with the surrounding residential context.

Policies	
COMZ-P1	<p>Enabled activities</p> <p>Enable a range of activities in the Commercial Zone that contribute positively to the purpose of the zone including:</p> <ol style="list-style-type: none"> 1. Commercial activities; 2. Retail activities, except for large-scale integrated retail activities; 3. Carparking activities; and 4. Residential activities, except for large-scale integrated retail activities; and 5. <u>Community corrections activities.</u>
COMZ-P2	<p>Managed activities</p> <p>Manage the location and scale of commercial activities which could result in cumulative adverse effects on the viability and vibrancy of centres, the retention and establishment of a mix of commercial activities within the Commercial Zone, and the function of the transport network.</p>
COMZ-P3	<p>Potentially incompatible activities</p> <p>Only allow all other activities where they will not have an adverse effect on the use of the zone for commercial activities. Potentially incompatible activities include:</p> <ol style="list-style-type: none"> 1. Community facilities; 2. Large-scale integrated retail activity; 3. Emergency service facilities; 4. Visitor accommodation; 5. Public transport activities; and 6. Residential activities at ground floor level.
COMZ-P4	<p>Avoiding industrial activities</p> <p>Avoid locating industrial activities and heavy industrial activities in the Commercial Zone.</p>
COMZ-P5	<p>Quality development outcomes design – neighbourhood and townscape outcomes</p> <p>Require new development, and alterations and additions to existing development at a site scale, to positively contribute to the sense of place, quality and amenity of the Commercial Zone by ensuring that it, where relevant:</p> <ol style="list-style-type: none"> <u>1.</u> Fulfil the intent Meets the requirements of the Centres and Mixed Use Design Guide where relevant; <u>2.</u> 4. Responds to the site context, particularly where it is located adjacent to: <ol style="list-style-type: none"> a. Residential zoned areas; and/or b. Open space zoned areas; <u>3.</u> 2. Provides a safe and comfortable pedestrian environment; <u>4.</u> 3. Enhances the quality of the streetscape and public / private interface; <u>5.</u> 4. Integrates with existing and planned active and public transport movement networks; and <u>6.</u> 5. Allows sufficient flexibility for ground floor space to be converted for a range of activities.

COMZ-P6	<p>On-site residential amenity</p> <p>Achieve a good standard of amenity for residential activities in the Commercial Zone by:</p> <ol style="list-style-type: none"> 1. Providing residents with adequate outlook; and 2. Providing access to convenient outdoor space, including private or shared communal areas; and 3. Fulfilling the intent of the Centres and Mixed Use Design Guide Meeting the requirements of the Residential Design Guide as relevant; and 4. Providing residents with adequate internal living space.
COMZ-P7	<p>Zone interfaces</p> <p>Require use and development of the Commercial Zone to maintain reasonable amenity for the adjoining Medium Density Residential Zone, Open Space Zones and other sensitive uses.</p>

Rules: Land use activities

COMZ-R1 Commercial activities

1. Activity status: **Permitted**

Where:

1. The commercial activity is a retail activity and does not exceed 500m² total GFA;
2. The commercial activity is a supermarket and does not exceed 1500m² total GFA; or
3. Any other commercial activity, including integrated retail activity that does not exceed 2500m² total GFA.

2. Activity status: **Restricted Discretionary**

Where:

a. Compliance with the requirements of COMZ-R1.1 cannot be achieved.

Matters of discretion are:

1. The matters in COMZ-P1, COMZ-P2 and COMZ-P3.

COMZ-R2 Residential activities

1. Activity status: **Permitted**

Where:

a. The activity is located above ground floor level.

2. Activity status: Restricted Discretionary	
Where:	
a. Compliance with the requirements of COMZ-R2.1 cannot be achieved.	
Matters of discretion are:	
1. The matters in COMZ-P1, COMZ-P3 and COMZ-P6;	
2. The extent to which the activity is the most appropriate to meet Wellington's future growth needs;	
3. The compatibility with existing activities nearby and other activities provided for in the Commercial Zone;	
4. The effect on the visual quality of the streetscape and the extent to which the development contributes to or detracts from the pedestrian environment; and	
5. The extent to which the activity enables or limits adaptability for future non-residential activity at ground floor level.	
COMZ-R3	Carparking activities
Activity status: Permitted	
COMZ-R4	<u>Community corrections activities</u>
<u>Activity status: Permitted</u>	
COMZ-R5	<u>Retirement Villages</u>
<u>Activity status: Discretionary</u>	
COMZ-R64	All other land use activities
1. Activity status: Discretionary	
Where:	
a. The activity is not otherwise provided for as a permitted activity, restricted discretionary activity, or a non-complying activity.	
COMZ-R75	Industrial activities
1. Activity Status: Non-complying	
COMZ-R86	Heavy industrial activities
1. Activity Status: Non-complying	
Rules: Building and structure activities	
COMZ-R97	Maintenance and repair of buildings and structures
1. Activity status: Permitted	
COMZ-R108	Demolition or removal of buildings and structures
1. Activity status: Permitted	
COMZ-R119	Construction of, or additions or alterations to, buildings and structures

<p>1. Activity status: Restricted Discretionary Matters of discretion are:</p> <ol style="list-style-type: none"> The matters in COMZ-P5, COMZ-P6 and COMZ-P7; The extent of compliance with standards COMZ-S1, COMZ-S2, COMZ-S3, COMZ-S4, COMZ-S5, COMZ-S6, COMZ-S7 and COMZ-S8; The Centres and Mixed-Use Design Guide; and The Residential Design Guide for any part of a building used for residential activities. 	
COMZ-R1240	Conversion of buildings or parts of buildings for residential activities or visitor accommodation
<p>1. Activity status: Restricted Discretionary Matters of discretion are:</p> <ol style="list-style-type: none"> The matters in COMZ-P1, COMZ-P3 and COMZ-P6; The extent of compliance with standards COMZ-S5, COMZ-S6 and COMZ-S7; <u>and</u> The Residential Design Guide; and <u>3.</u> In relation to the conversion of the ground floor to residential activities, the extent to which the conversion enables the ground floor level to be returned to use for non-residential activities. 	

Standards	
COMZ-S1	Maximum height
<p>1. A maximum height limit of 8m above ground level must be complied with.</p> <p>These standards do not apply to:</p> <ol style="list-style-type: none"> Accessory buildings. Fences or standalone walls no greater than 1.8 metres in height where these are not for the purpose of screening an outdoor storage area. Solar panel and heating components attached to a building provided these do not exceed the height by more than 500mm; Satellite dishes, antennas, aerials, chimneys, flues, architectural or decorative features (e.g. finials, spires) provided that none of these exceed 1m in diameter and do not exceed the height by more than 1m; and Lift overruns provided these do not exceed the height by more than 1m. 	
<p>Assessment criteria where the standard is infringed:</p> <ol style="list-style-type: none"> Streetscape and visual amenity effects; Dominance, privacy and shading effects on adjoining sites; and The extent to which taller buildings would contribute to a substantial increase in residential accommodation. 	
COMZ-S2	Height in relation to boundary
<p>1. No part of any building or structure may project beyond the relevant recession plane shown below:</p>	
Location	Recession plane
Boundary adjoining any site within the MRZ with a height limit of 11m identified on the District Plan Maps	60° measured from a height of 4m vertically above ground level
<p>Assessment criteria where the standard is infringed:</p> <ol style="list-style-type: none"> Dominance, privacy, and shading effects on adjoining sites; Whether an increase in height in relation to boundary results from a response to natural hazard mitigation; Effects on public spaces; and The extent to which an increase in height in relation to boundary would contribute to a 	

Boundary adjoining any site within an Open Space Zone	60° measured from a height of 5m vertically above ground level	substantial increase in residential accommodation.
<p>These standards do not apply to:</p> <ol style="list-style-type: none"> A boundary with a road. Internal boundaries; Fences or standalone walls no greater than 1.8 metres in height where these are not for the purpose of screening an outdoor storage area. Solar power and heating components attached to a building provided these do not exceed the height in relation to boundary by more than 500mm; and Satellite dishes, antennas, aerials, chimneys, flues, architectural or decorative features (e.g. finials, spires) provided that none of these exceed 1m in diameter and do not exceed the height in relation to boundary by more than 3m measured vertically. 		
<p>COMZ-S3 Minimum ground floor height</p>		
<p>1. The minimum ground floor height to underside of structural slab or equivalent shall be 4m.</p>	<p>Assessment criteria where the standard is infringed:</p> <ol style="list-style-type: none"> The extent to which a reduced height: <ol style="list-style-type: none"> Will compromise or preclude future use or adaptation of the ground floor for non-residential activities; Is necessary to provide for the functional or operational needs of a proposed activity; and Whether topographical or other site constraints make compliance with the standard impracticable or unnecessary. 	
<p>COMZ-S4 Verandah control</p>		
<p>1. Any verandah constructed on any building frontage facing a public space, including roads, must:</p> <ol style="list-style-type: none"> Have a minimum clearance of 2.5m directly above the footpath or formed ground surface; Not exceed a maximum height of 4m measured between the base of the verandah fascia and the footpath or formed ground surface directly below; Be setback a minimum of 450mm from any point along the kerbing extending back to the site boundary; and Not exceed a maximum width of 3m from the front of the building. <p><u>The standard does not apply to service stations.</u></p>	<p>Assessment criteria where the standard is infringed:</p> <ol style="list-style-type: none"> The extent to which any non-compliance is necessary to provide for functional or operational requirements of the activities on the site, or for people's health and safety; Whether sufficient clearance is provided for pedestrians and the delivery of goods where any verandah is proposed lower than 2.5m above the footpath or ground surface level; and The extent to which any verandahs wider than 3m or within 450mm of any kerbing allow clearance for unencumbered vehicle movement, parking and loading. 	

COMZ-S5		Minimum residential unit size		
1. Residential units, including dual key units, must meet the following minimum sizes:		Assessment criteria where the standard is infringed: 1. The extent to which: a. The design of the proposed unit provides a good standard of amenity for the occupants; and b. Other on-site factors compensate for a reduction in unit sizes.		
Residential unit type	Minimum net floor area			
a. Studio unit	35m ²			
b. 1 bedroom unit	40m ²			
c. 2+ bedroom unit		55m ²		
COMZ-S6		Outdoor living space for residential units		
1. Each residential unit, including any dual key unit, must be provided with either a private outdoor living space or access to a communal outdoor living space; 2. Where private outdoor living space is provided it must be: a. For the exclusive use of residents; b. Directly accessible from a habitable room; c. A single contiguous space; and d. Of the minimum area and dimension specified in the table below; and 3. Where communal outdoor living space is provided it does not need to be in a single continuous space but it must be: a. Accessible from the residential units it serves; b. Of the minimum area and dimension specified in the table below; and c. Free of buildings, parking spaces, and servicing and maneuvering areas.		Assessment criteria where the standard is infringed: The extent to which: 1. Any proposed outdoor living space provides a good standard of amenity relative to the number of occupants the space is designed for; 2. Other on-site factors compensate for a reduction in the size or dimension of the outdoor living space; and 3. The availability of public space in proximity to the site.		
Living space type	Minimum area	Minimum dimension		
a. Private				
i. Studio unit and 1-bedroom unit	5m ²	1.8m		
ii. 2+ bedroom unit	8m ²	1.8m		
b. Communal				
i. For every 4-15 units	1064 m ²	8m		
ii. <u>For each additional unit above 15 units.</u>	<u>2m²</u>			
<u>Communal outdoor living space is calculated based on the number of units not provided with the minimum area of private outdoor living space.</u>				

COMZ-S7	Minimum outlook space for residential units	
<p>1. Every residential unit must be designed to achieve a minimum of 1m by 1m outlook space for all habitable rooms.</p>	<p>Assessment criteria where the standard is infringed:</p> <ol style="list-style-type: none"> 1. The extent to which: <ol style="list-style-type: none"> a. The design of the proposed unit provides a good standard of amenity; and b. Other on-site factors compensate for a reduction in outlook space. 	
COMZ-S8	Building setback controls	
<p>1. Buildings must be located outside of the building setback (Western Escarpment) and building setback (Whitehead Road).</p>	<p>Assessment criteria where the standard is infringed:</p> <ol style="list-style-type: none"> 1. The extent to which: <ol style="list-style-type: none"> a. Landscaping mitigates the placement of buildings within the setback; and b. There is a functional need or operational need for the buildings or structures to be located within the building setback (Western Escarpment) and building setback (Whitehead Road). 	

This entire chapter has been notified using the RMA Part One, Schedule 1 process ([P1 Sch1](#)).

He Rohe Whakamahinga Rau

Mixed Use Zone

MUZ	Mixed Use Zone
------------	-----------------------

Introduction

The purpose of the Mixed Use Zone is to provide for a compatible mixture of residential, commercial, light industrial, recreational and/or community activities. It continues the long-standing approach of enabling a wide range of compatible activities in Wellington's suburban employment areas. The Zone covers areas where people can live, work, play, and conduct business but with fewer day-to-day conveniences than may be available in the City Centre Zone and other Centres.

The Mixed Use Zone is distributed across the city. A broad range of activities are enabled to occur alongside one another in the Mixed Use Zone. It needs to be noted that due to the wide range of non-residential activities provided for, and the potential for industrial activities to establish in this Zone, there may be moderate to high levels of noise, vehicle trip generation or other environmental effects. While such effects may be tolerable within the Mixed Use Zone, they could undermine the amenity of zones nearby if not appropriately managed. Effects from new activities and development within the Mixed Use Zone need to be compatible with the local context. Activities that generate adverse effects of a nature or scale that is potentially incompatible with the existing context will typically not be enabled in the Mixed Use Zone unless such activities can demonstrate they are able to co-exist with existing sensitive activities in the vicinity.

Because the Mixed Use Zone provides for a range of activities, a different level of external amenity should be expected for residential uses that locate within the Zone than would be expected in the Centres or Residential Zones. To ensure the supply of business land is sufficient to meet the City's short, medium and long term needs, the Mixed Use Zone discourages ground floor residential development. New residential uses and conversions of existing non-residential activities for residential use above ground floor can be established in the Mixed Use Zone where appropriate. Such uses will need to provide quality on-site amenity and be designed and constructed in a manner that does not undermine the ongoing functional operation and development of the Mixed Use Zone for a wide range of non-residential activities.

Development in the Mixed Use Zone needs to be of a nature and scale that supports the social, cultural and economic importance of the City Centre and other Centres. It is vital that the City Centre remains the economic and employment hub for the Region and that the Metropolitan, Local and Neighbourhood Centres are vibrant and well-functioning. The zone does not anticipate large supermarkets or integrated retail activity, which is more appropriately located in the Metropolitan Centres Zone, Local Centre Zone, Neighbourhood Centre Zone or City Centre Zone.

Other relevant District Plan provisions

There may be a number of provisions that apply to an activity, building, structure or site. Resource consent may therefore be required under rules in this chapter as well as other chapters. Unless specifically stated in a rule, resource consent is required under each relevant rule. The steps to determine the status of an activity are set out in the General Approach chapter.

Objectives

MUZ-O1	<p>Purpose</p> <p>The Mixed Use Zone is developed and used for a wide range of compatible activities.</p>
MUZ-O2	<p>Accommodating growth</p> <p>The Mixed Use Zone has an important role in accommodating growth and has sufficient serviced, resilient development capacity <u>and additional infrastructure</u> to meet business, and to a lesser extent residential growth needs.</p>
MUZ-O3	<p>Compatibility with other employment areas and the hierarchy of centres</p> <p>Activities and development will be of an appropriate scale and type that do not undermine the vitality, role and function of the City Centre and other Centres as set out in the hierarchy of centres.</p>
MUZ-O4	<p>Amenity and design</p> <p>Development in the Mixed Use Zone positively contributes to creating a well-functioning urban environment and a diverse local context.</p>
MUZ-O5	<p>Managing adverse effects</p> <p>Adverse effects from use and development of the Mixed Use Zone are managed effectively, particularly on more sensitive environments in neighbouring zones.</p>
Policies	
MUZ-P1	<p>Accommodating growth</p> <p>Provide for the use and development of the Mixed Use Zone to meet the City's needs for business activities and to a lesser extent housing, including:</p> <ol style="list-style-type: none"> 1. A <u>choice-variety</u> of building type, size, affordability and distribution, including forms of medium density housing; 2. Efficient, well integrated and strategic use of available development sites; and 3. Convenient access to state highways and key transport routes.
MUZ-P2	<p>Enabled activities</p> <p>Enable a wide range of compatible activities in the Mixed Use Zone where they are of an appropriate nature, scale and intensity for the zone and the hierarchy of centres, including:</p> <ol style="list-style-type: none"> 1. Commercial activities; 2. Community facilities; 3. Educational facilities; 4. Recreation activities; 5. Arts, culture and entertainment activities; 6. Emergency service facilities; 7. Community corrections <u>facilitiesactivities</u>; 8. Visitor accommodation; 9. Recreational facilities; 10. Residential activities above ground floor level; 11. Public transport activities; and 12. Industrial activities.
MUZ-P3	<p>Managing larger-scale retail activities</p> <p>Only allow the establishment of integrated retail activities and large supermarkets in the Mixed Use Zone if it can be demonstrated that they will:</p>

	<ol style="list-style-type: none"> 1. Not result in significant adverse impacts on the viability, vitality, role and function of the City Centre or any Metropolitan, Local or Neighbourhood Centres; 2. Not result in significant adverse impacts on the sustainability, safety or efficiency of the transport network and the hierarchy of roads from trip patterns, travel demand or vehicle use; and 3. Be compatible with adjoining land uses.
MUZ-P4	Avoiding heavy industrial activities Avoid heavy industrial activities from locating in the Mixed Use Zone.
MUZ-P5	Residential activities Ensure the ongoing functional use of the Mixed Use Zone for a range of business uses by: <ol style="list-style-type: none"> 1. Restricting residential activities being established at the ground floor level of buildings; and 2. Ensuring residential activities are designed and constructed to provide good on-site amenity and to avoid reverse sensitivity effects on non-residential activities within the zone; and 3. Fulfilling the intent of the Centres and Mixed Use Design Guide. Meeting the requirements of the Residential Design Guide as relevant.
MUZ-P6	Design of new development Encourage a high standard of built form and amenity while: <ol style="list-style-type: none"> a. Enabling innovation and choice in the design of new built development to reflect the diverse neighbourhood context of the Mixed Use Zone; and b. Meeting the intentions Fulfilling the intent of the Centres and Mixed Use Design Guide as relevant.
MUZ-P7	Zone interfaces Require use and development of the Mixed Use Zone to maintain a reasonable amenity for adjoining Residential or Open Space Zones or other sensitive uses.
Rules: Land use activities	
MUZ-R1	Commercial activities
	<ol style="list-style-type: none"> 1. Activity status: Permitted Where: <ol style="list-style-type: none"> a. The activity is not an Integrated Retail Activity (refer to Rule MUZ-R11); and b. The activity is not a supermarket (refer to MUZ-R12).
MUZ-R2	Community facilities
	<ol style="list-style-type: none"> 1. Activity status: Permitted
MUZ-R3	Educational facilities
	<ol style="list-style-type: none"> 1. Activity status: Permitted
MUZ-R4	Arts, culture and entertainment activities
	<ol style="list-style-type: none"> 1. Activity status: Permitted
MUZ-R5	Emergency services facilities
	<ol style="list-style-type: none"> 1. Activity status: Permitted
MUZ-R6	Community corrections facilitiesactivities

1. Activity status: Permitted	
MUZ-R7	Visitor accommodation
1. Activity status: Permitted	
MUZ-R8	Recreational activities
1. Activity status: Permitted	
MUZ-R9	Public transport activities
1. Activity status: Permitted	
MUZ-R10	Residential activities
<p>1. Activity status: Permitted</p> <p>Where:</p> <p>a. The activity is located above ground floor level.</p>	
<p>2. Activity status: Restricted Discretionary</p> <p>Where:</p> <p>a. Compliance with the requirements of MUZ-R10.1 cannot be achieved.</p> <p>Matters of discretion are:</p> <ol style="list-style-type: none"> 1. The matters in MUZ-P1, MUZ-P2 and MUZ-P5; 2. The extent to which the activity is the most appropriate to meet Wellington's future growth needs; 3. The compatibility with existing activities nearby and other activities provided for in the Mixed Use Zone; 4. The effect on the visual quality of the streetscape and the extent to which the development contributes to or detracts from the pedestrian environment; and 5. The extent to which the activity enables or limits adaptability for future non-residential activity at ground floor level. <p>Notification status: An application for resource consent made in respect of rule MUZ-R10.2.a is precluded from being publicly notified.</p>	
MUZ-R11	Integrated retail activity
<p>1. Activity status: Permitted</p> <p>Where:</p> <p>a. The integrated retail activity comprises large format retail and does not exceed 10,000m² total GFA; or</p> <p>b. The integrated retail activity does not comprise large format retail and does not exceed 2,500m² total GFA.</p>	
<p>2. Activity status: Restricted Discretionary</p> <p>Where:</p> <p>a. Compliance any of the requirements of MUZ-R11.1 cannot be achieved.</p> <p>Matters of discretion are:</p> <ol style="list-style-type: none"> 1. The matters in MUZ-P3. <p>The Council will not apply a permitted baseline assessment when considering the effects of integrated retail activities that cannot comply with MUZ-R11.1.</p>	

MUZ-R12	Supermarkets
<p>1. Activity status: Permitted</p> <p>Where:</p> <p>a. The total gross floor area does not exceed 1,500m².</p>	
<p>2. Activity status: Restricted Discretionary</p> <p>Where:</p> <p>a. Compliance with the requirements of MUZ-R12.1 cannot be achieved.</p> <p>Matters of discretion are:</p> <p>1. The matters in MUZ-P3.</p> <p>The Council will not apply a permitted baseline assessment when considering the effects of supermarkets that cannot comply with MUZ-R12.1.</p>	
MUZ-R13	Retirement Villages
<p>1. Activity status: Discretionary</p>	
MUZ-R1413	All other activities
<p>1. Activity status: Discretionary</p> <p>Where:</p> <p>a. The activity is not otherwise provided for as a permitted activity, restricted discretionary activity, or non-complying activity.</p>	
Rules: Building and structure activities	
MUZ-R1514	Maintenance and repair of buildings and structures
<p>1. Activity status: Permitted</p>	
MUZ-R1615	Demolition or removal of buildings and structures
<p>1. Activity status: Permitted</p>	
MUZ-R1716	Construction of, or additions and alterations to, buildings and structures
<p>1. Activity status: Permitted</p> <p>Where:</p> <p>a. Compliance with the following standards is achieved:</p> <ul style="list-style-type: none"> i. MUZ-S1; ii. MUZ-S3; iii. MUZ-S4; iv. MUZ-S5; v. MUZ-S6; vi. MUZ-S7; vii. MUZ-S11; and <p>b. The activity is not the construction of a new building for residential activities.</p>	
<p>2. Activity status: Restricted Discretionary</p>	

Where:

- a. Compliance with any of the requirements of MUZ-R16.1 cannot be achieved.

Matters of discretion are :

1. The matters in MUZ-P2, MUZ-P5, MUZ-P6 and MUZ-P7;
2. The extent and effect of non-compliance with MUZ-S1, MUZ-S3, MUZ-S4, MUZ-S5, MUZ-S6, MUZ-S7 and MUZ-S11 as specified in the associated assessment criteria for the infringed standards;
3. The extent of compliance with MUZ-S2; and
4. The extent of compliance with MUZ-S8, MUZ-S9 and MUZ-S10 for any part of the building used for residential activities;
- ~~5. The Centres and Mixed-Use Design Guide; and~~
- ~~6. The Residential Design Guides for any part of a building used for residential activities.~~

Notification status:

An application for resource consent made in respect of rule MUZ-~~R1746~~.2.a that results from non-compliance with MUZ-S4 or MUZ-S6 is precluded from being publicly or limited notified.

An application for resource consent made in respect of rule MUZ- ~~R1746~~.2.a that results from non-compliance with MUZ-S1 but that complies with both MUZ-S2 and MUZ-S3 is precluded from being publicly or limited notified.

MUZ-~~R1847~~ Conversion of buildings or parts of buildings for residential activities

1. Activity status: **Restricted Discretionary**

Matters of discretion are:

1. The matters in MUZ-P2 and MUZ-P5;
2. The extent of compliance with standards MUZ-S8, MUZ-S9 and MUZ-S10;
- ~~3. The Residential Design Guide; and~~
3. The extent to which the conversion enables the ground floor level to be used or adapted for future non-residential activities; and
4. The availability and connection to existing or planned three waters infrastructure.

Notification status: An application for resource consent made in respect of rule MUZ-~~R1847~~.1 is precluded from being either publicly or limited notified.

MUZ-~~R1948~~ Outdoor storage areas

1. Activity status: **Permitted**

Where:

- a. The storage area is screened by either a fence or landscaping of 1.8m in height from any adjoining road or site.
- b. Screening does not obscure emergency or safety signage or obstruct access to emergency panels, hydrants, shut-off valves, or other emergency response facilities.

2. Activity status: **Restricted discretionary**

Where:

- a. Compliance with the requirements of MUZ-~~R1948~~.1 cannot be achieved.

Matters of discretion are:

1. The matters in MUZ-P6 and MUZ-P7;

2. The extent to which any lesser screening is necessary to provide for functional needs or operational needs of the activities on the site, or for people’s health and safety; and
3. Visual amenity effects.

Notification status: An application for resource consent made in respect of rule MUZ-~~R1948~~.2.a is precluded from being publicly notified.

MUZ-R20	Industrial Activities
	<p>1. <u>Activity status: Permitted</u></p> <p><u>Where:</u></p> <p>a. <u>The activity is not a heavy industrial activity.</u></p>
	<p>2. <u>Activity status: Non-complying</u></p> <p><u>Where:</u></p> <p>a. <u>Compliance with the requirements of MUZ-R20.1 cannot be achieved.</u></p>

Standards

MUZ-S1	Maximum height for the purposes of MUZ-R1746.1	
<p>1. The following maximum height limits above ground level must be complied with:</p>		<p>Assessment criteria where the standard is infringed:</p> <ol style="list-style-type: none"> 1. Streetscape and visual amenity effects; 2. Dominance, privacy and shading effects on adjoining sites; and 3. The extent to which taller buildings would contribute to a substantial increase in residential accommodation.
Location	Limit	
Height control area 1 Newtown South Greta Point Tawa South Takapu Island Tauhinu Road Rongotai South Mixed Use Zone Height Control A Rongotai South Mixed Use Zone Height Control B Shelly Bay Tawa: Tawa Street	12 metres	
Height control area 2 Tawa Junction Kaiwharawhara Kilbirnie North Miramar - Park Road and Weka Street	15 metres	
Height control area 3 Rongotai South Mixed Use Zone Height Control B Rongotai South Mixed Use Zone Height Control C	16 metres	
Height control area 4 Miramar - Ropa Lane, Maupuia Road	18 metres	

<p>Ngauranga Tawa Junction Takapu Island</p>		
<p>2. Fences and standalone walls must not exceed a maximum height of 1.8 metres (measured above ground level).</p> <p>This standard does not apply to:</p> <ol style="list-style-type: none"> 1. Accessory buildings; 2. Solar panel and heating components attached to a building provided these do not exceed the height by more than 500m; 3. Satellite dishes, antennas, aerials, chimneys, flues, architectural or decorative features (e.g. finials, spires) provided that none of these exceed 1m in diameter and do not exceed the height by more than 1m; and 4. Lift overruns provided these do not exceed the height by more than 4m. 		

MUZ-S2	Maximum height for the purposes of MUZ-R1746.2
---------------	---

<p>1. The following maximum height limits above ground level must be complied with:</p>	<p>Assessment criteria where the standard is infringed:</p>				
<table border="1"> <thead> <tr> <th data-bbox="116 862 593 913">Location</th> <th data-bbox="593 862 798 913">Limit</th> </tr> </thead> <tbody> <tr> <td data-bbox="116 913 593 1057"> Height control area 1 Rongotai South Mixed Use Zone Height Control B </td> <td data-bbox="593 913 798 1057"> 16 metres </td> </tr> </tbody> </table>	Location	Limit	Height control area 1 Rongotai South Mixed Use Zone Height Control B	16 metres	<ol style="list-style-type: none"> 1. Streetscape and visual amenity effects; 2. Dominance, privacy and shading effects on adjoining sites; and 3. The extent to which taller buildings would contribute to a substantial increase in residential accommodation.
Location	Limit				
Height control area 1 Rongotai South Mixed Use Zone Height Control B	16 metres				
<table border="1"> <tbody> <tr> <td data-bbox="116 1057 593 1444"> Height control area 2 Newtown South Greta Point Tawa: Tawa South Takapu Island Miramar: - Ropa Lane, Maupuia Road and Tauhinu Road Rongotai South Mixed Use Zone Height Control A Rongotai South Mixed Use Zone Height Control C </td> <td data-bbox="593 1057 798 1444"> 18 metres </td> </tr> </tbody> </table>	Height control area 2 Newtown South Greta Point Tawa: Tawa South Takapu Island Miramar: - Ropa Lane, Maupuia Road and Tauhinu Road Rongotai South Mixed Use Zone Height Control A Rongotai South Mixed Use Zone Height Control C	18 metres			
Height control area 2 Newtown South Greta Point Tawa: Tawa South Takapu Island Miramar: - Ropa Lane, Maupuia Road and Tauhinu Road Rongotai South Mixed Use Zone Height Control A Rongotai South Mixed Use Zone Height Control C	18 metres				
<table border="1"> <tbody> <tr> <td data-bbox="116 1444 593 1585"> Height control area 3 Rongotai South Mixed Use Zone Height Control D </td> <td data-bbox="593 1444 798 1585"> 19 metres </td> </tr> </tbody> </table>	Height control area 3 Rongotai South Mixed Use Zone Height Control D	19 metres			
Height control area 3 Rongotai South Mixed Use Zone Height Control D	19 metres				
<table border="1"> <tbody> <tr> <td data-bbox="116 1585 593 1758"> Height control area 4 Tawa: Tawa Junction Tawa: Redwood Avenue Tawa: Tawa Street </td> <td data-bbox="593 1585 798 1758"> 22 metres </td> </tr> </tbody> </table>	Height control area 4 Tawa: Tawa Junction Tawa: Redwood Avenue Tawa: Tawa Street	22 metres			
Height control area 4 Tawa: Tawa Junction Tawa: Redwood Avenue Tawa: Tawa Street	22 metres				
<table border="1"> <tbody> <tr> <td data-bbox="116 1758 593 1995"> Height control area 5 Glenside Kaiwharawhara Sar Street Kilbirnie North Miramar: Park Road and Weka Street </td> <td data-bbox="593 1758 798 1995"> 22.5 metres </td> </tr> </tbody> </table>	Height control area 5 Glenside Kaiwharawhara Sar Street Kilbirnie North Miramar: Park Road and Weka Street	22.5 metres			
Height control area 5 Glenside Kaiwharawhara Sar Street Kilbirnie North Miramar: Park Road and Weka Street	22.5 metres				

Height control area 6 Ngauranga: Malvern	24 metres	
Height control area 7 Shelly Bay	27 metres	
<p>2. Fences and standalone walls must not exceed a maximum height of 1.8 metres (measured above ground level).</p> <p>This standard does not apply to:</p> <ol style="list-style-type: none"> Accessory buildings; Solar panel and heating components attached to a building provided these do not exceed the height by more than 500mm; Satellite dishes, antennas, aerials, chimneys, flues, architectural or decorative features (e.g. finials, spires) provided that none of these exceed 1m in diameter and do not exceed the height by more than 1m; and Lift overruns provided these do not exceed the height by more than 4m. 		
MUZ-S3	Height in relation to boundary	
<p>1. No part of any building or structure may project beyond the relevant recession plane shown below:</p>		<p>Assessment criteriacriteria where the standard is infringed:</p> <ol style="list-style-type: none"> The extent to which any infringement is necessary to provide for functional needs or operational needs of the activities on the site; Dominance, privacy and shading effects on adjoining sites; Whether topographical or other site constraints make compliance with the standard impracticable; Whether an increase in height in relation to boundary results from a response to natural hazard mitigation; The extent to which an increase in height in relation to boundary would contribute to a substantial increase in residential accommodation; and The effect on the function and associated amenity values of any adjacent open space zone.
Location	Recession plane	
Boundary adjoining any site within the MRZ with a height limit of 11m identified on the District Plan Maps	60° measured from a height of 4m vertically above ground level	
Boundary adjoining any site within the MRZ with a height limit of 14m identified on the District Plan Maps	60° measured from a height of 5m vertically above ground level	
Boundary adjoining any site within the HRZ	60° measured from a height of 8m vertically above ground level	
Boundary adjoining any site within an Open Space Zone	60° measured from a height of 5m vertically above ground level	
<u>Boundary adjoining any site containing a scheduled heritage building</u>	<u>60° measured from a height of 5m vertically above ground level</u>	
<p>These standards do not apply to:</p>		

<ul style="list-style-type: none"> a. A boundary with a road; b. Internal boundaries; c. Solar power or heating components provided these do not exceed the height in relation to boundary by more than 500mm measured vertically; d. Satellite dishes, antennas, aerials, chimneys, flues, architectural or decorative features (e.g. finials, spires) provided that none of these exceed 1m in diameter and do not exceed the height in relation to boundary by more than 3m measured vertically; and e. Lift overruns, provided these do not exceed the height in relation to boundary by more than 1m measured vertically. 	
MUZ-S4	Minimum ground floor height
<ul style="list-style-type: none"> 1. The minimum ground floor height to the underside of structural slab or equivalent for any new building, or addition or alterations to an existing building shall be 4m. 	<p>Assessment criteria where the standard is infringed:</p> <ul style="list-style-type: none"> 1. The extent to which a reduced height: <ul style="list-style-type: none"> a. Will compromise or preclude future alternative ground floor uses; b. Is necessary to provide for functional needs or operational needs of a proposed activity; 2. Whether topographical or other site constraints make compliance with the standard impracticable or unnecessary; 3. The extent to which the ground floor level will be able to be used or adapted for future non-residential activities; and 4. Whether, for any additions or alterations, the existing ground floor height infringes the standard.
MUZ-S5	Windows adjacent to Residential Zones
<ul style="list-style-type: none"> 1. <u>Except for windows in a residential unit, opaque</u> privacy glazing must be installed in windows where: <ul style="list-style-type: none"> a. The associated building wall faces a site in any Residential Zone; and b. The wall is located within 5m of the boundary of a site in any Residential Zone. 	<p>Assessment criteria where the standard is infringed:</p> <ul style="list-style-type: none"> 1. Privacy effects on adjoining sites; and 2. Positive safety implications of over-looking public space.
MUZ-S6	Maximum gross floor area of buildings
<ul style="list-style-type: none"> 1. Any building must not exceed a maximum gross floor area of 500m². 	<p>Assessment Criteria where the standard is infringed:</p> <ul style="list-style-type: none"> 1. The extent to which the additional floor area is necessary to provide for functional needs or operational needs of the activities on the site; 2. Dominance, privacy and shading effects on adjoining sites; and 3. The extent to which the design, appearance and location of the building on the site mitigates the visual impact or dominance effects of the additional building area on the surrounding area.
MUZ-S7	Verandah control

<p>1. Any verandah constructed on any building frontage facing a public space, including roads, must:</p> <ol style="list-style-type: none"> a. Have a minimum clearance of 2.5m directly above the footpath or formed ground surface; b. Not exceed a maximum height of 4m measured between the base of the verandah fascia and the footpath or formed ground surface directly below; c. Be setback a minimum of 450mm from any point along the kerbing extending back to the site boundary; and d. Not exceed a maximum width of 3m from the front of the building. <p><u>This standard does not apply to:</u></p> <p>a. <u>Service stations.</u></p>	<p>Assessment criteria where the standard is infringed:</p> <ol style="list-style-type: none"> 1. The extent to which any non-compliance is necessary to provide for functional or operational requirements of the activities on the site, or for people's health and safety; 2. Whether sufficient clearance is provided for pedestrians and the delivery of goods where any verandah is proposed lower than 2.5m above the footpath or ground surface level; and 3. The extent to which any verandahs wider than 3m or within 450mm of any kerbing allow clearance for unencumbered vehicle movement, parking and loading.
---	---

MUZ-S8	Minimum residential unit size		<p>Assessment criteria where the standard is infringed:</p> <ol style="list-style-type: none"> 1. The extent to which: <ol style="list-style-type: none"> a. The design of the proposed unit provides a good standard of amenity; and b. Other on-site factors compensate for a reduction in unit sizes.
1. Residential units, including dual key units, must meet the following minimum sizes:			
Residential unit type	Minimum net floor area		
a. Studio unit	35m ²		
b. 1 bedroom unit	40m ²		
c. 2+ bedroom unit	55m ²		

MUZ-S9	Outdoor living space for residential units			<p>Assessment criteria where the standard is infringed:</p> <p>The extent to which:</p> <ol style="list-style-type: none"> 1. Any proposed outdoor living space provides a good standard of amenity relative to the number of occupants the space is designed for; 2. Other on-site factors compensate for a reduction in the size or dimensions of the outdoor living space; and 3. The availability of public space in proximity to the site.
1. Each residential unit, including any dual key unit, must be provided with either a private outdoor living space or access to a communal outdoor living space;				
2. Where private outdoor living space is provided it must be: <ol style="list-style-type: none"> a. For the exclusive use of residents; b. Directly accessible from a habitable room; c. A single contiguous space; and d. Of the minimum area and dimension specified in the table below; and 				
3. Where communal outdoor living space is provided it does not need be in a single continuous space but it must be: <ol style="list-style-type: none"> a. Accessible from the residential units it serves; b. Of the minimum area and dimension specified in the table below; and c. Free of buildings, parking spaces, and servicing and maneuvering areas. 				
Living space type		Minimum area	Minimum dimension	
a. Private				

i. Studio unit and 1-bedroom unit	5m ²	1.8m
ii. 2+ bedroom unit	8m ²	1.8m
b. Communal		
i. For every 5 4 – 15 units	6410m ²	8m
ii. <u>For each additional unit above 15 units</u>	2m ²	=

Communal outdoor living space is calculated based on the number of units not provided with the minimum area of private outdoor living space.

MUZ-S10	Minimum Outlook space for multi-unit housing	
1. Every residential unit must be designed to achieve a minimum of 1m by 1m outlook space for all habitable rooms.	Assessment criteria where the standard is infringed: <ol style="list-style-type: none"> 1. The extent to which: <ol style="list-style-type: none"> a. The design of the proposed unit provides a good standard of amenity; and b. Other on-site factors compensate for a reduction in outlook space. 	
MUZ-S11	Lyllall Bay Parade frontage control	
1. New buildings built on a site adjoining the Open Space Zone and Recreation Zoned land fronting Lyllall Parade must be built in alignment with the existing Lyllall Parade street frontage; and 2. Any addition to, alteration or modification of a building or structure on a site adjoining the Open Space Zone and Recreation Zoned land fronting Lyllall Bay Parade, where the works are confined to the area below verandah level must not create a featureless façade.	Assessment criteria where the standard is infringed <ol style="list-style-type: none"> 1. The extent to which the effectiveness of any landscaping, screening or other site mitigation proposed creates visual interest of the streetscape and façade relief. 	
MUZ-S12	<u>Boundary setback from a rail corridor</u>	
1. <u>Boundary or structures must not be located within 1.5m setback from a rail corridor boundary.</u>	Assessment criteria where the standard is infringed: <ol style="list-style-type: none"> 1. <u>The extent to which the location and design of the building relates to the ability to safely use, access and maintain buildings without requiring access on, above or over the rail corridor.</u> 	

Parts of this chapter have been notified using either a Part One Schedule 1 process ([P1 Sch1](#)), or as part of an Intensification Planning Instrument using the Intensification Streamlined Planning Process ([ISPP](#)). Please see notations.

He Rohe Paetata Tāone

Metropolitan Centre Zone

MCZ	Metropolitan Centre Zone
------------	---------------------------------

P1 Sch1

Introduction

The purpose of the Metropolitan Centre Zone is to provide predominantly for a broad range of commercial, community, recreational and residential activities. The Metropolitan Centre Zone applies to the Johnsonville and Kilbirnie metropolitan centres.

The Metropolitan Centre Zone is a focal point for sub-regional urban catchments and provides significant support to the City Centre Zone by offering key services to the outer suburbs of Wellington City and the wider region. This is identified in the Wellington Regional Policy Statement. These centres contain a wide range of commercial, civic and government services, office, community, recreational, entertainment and residential activities and have well established access to public transport.

The Johnsonville and Kilbirnie metropolitan centres will play a critical role in accommodating forecast population growth and have significant development/redevelopment potential. To support and encourage intensification, the Metropolitan Centre Zone provides [an opportunity for substantial building heights to be realised](#)~~substantial height limits~~. Given the significant development potential in the Metropolitan Centre Zones, comprehensive development and the integrated and coordinated development of larger sites is required to act as a catalyst for positive change and demonstrate density done well.

High quality building design is a focus for these centres. The transition to more intensive use in metropolitan centres will result in significant changes to existing amenity values and design in the centres and their surrounds. Redevelopment will be supported by a range of measures to promote good design and environmental outcomes and address amenity issues. Accordingly, most building activities will require a resource consent and an assessment against the Centres and Mixed Use Design Guide.

There is an identified need for significant residential intensification within and around the Metropolitan Centres. ~~These centres are subject to the intensification policies 3 (b) and (c) of the National Policy Statement on Urban Development 2020 (NPS-UD).~~ Accordingly, residential activity is permitted above ground floor within the centres and the High Density Residential Zone has been applied within a walkable catchment of the edge of these centres. The ~~cumulative~~ risk from natural hazards ~~in Kilbirnie is that the intensification of this area has been tempered as a qualifying matter under Subpart 6, clause 3.32 of the NPS-UD~~ [has been addressed by applying the natural hazards overlay](#).

To support a mix of activities within the Zone, activities that have off-site effects, such as industrial activities and different retail formats, will need to be managed. There is however a desire for larger scale retail to locate in centres, where these are of an appropriate form and scale, rather than at out-of-centre locations, to support the vitality [and viability](#) of centres.

Other relevant District Plan provisions
--

There may be a number of provisions that apply to an activity, building, structure or site. Resource consent may therefore be required under rules in this chapter as well as other chapters. Unless specifically stated in a rule, resource consent is required under each relevant rule. The steps to determine the status of an activity are set out in the General Approach chapter.

Objectives	
ISPP	<p>MCZ-O1 Purpose</p> <p>The Metropolitan Centre Zone meets the sub-regional needs of communities, businesses and residents in a manner that supports the City’s strategic direction for compact urban growth and its sub-regional role and function in the City’s hierarchy of centres.</p>
ISPP	<p>MCZ-O2 Accommodating growth</p> <p>The Metropolitan Centre Zone plays a significant role in accommodating growth and has sufficient serviced, resilient development capacity <u>and additional infrastructure</u> to meet commercial and residential growth needs.</p>
ISPP	<p>MCZ-O3 Amenity and design</p> <p>Medium and high density mixed-use development is achieved that positively contributes to a good quality, well-functioning urban environment that reflects the changing urban form and amenity values of the Metropolitan Centres Zone.</p>
ISPP	<p>MCZ-O4 Activities</p> <p>Activities will be of an appropriate scale and type to enhance the vibrancy <u>and viability</u> of Metropolitan Centres, <u>support walkable neighbourhoods</u> and reflect their sub-regional purpose.</p>

Policies	
ISPP	<p>MCZ-P1 Accommodating growth</p> <p>Provide for the use and development of the Metropolitan Centre Zone to meet the City's needs for housing, business activities and community facilities, including:</p> <ol style="list-style-type: none"> 1. A variety of building types, sizes, tenures, affordability and distribution of a scale and intensity that does not undermine the ongoing viability, vibrancy and primacy of the City Centre Zones supports the purpose of the zone; 2. A mix of medium and high-density housing; 3. Convenient access to active transport and public transport options; 4. Efficient, well integrated and strategic use of available development sites; and 5. Convenient access to a range of open spaces.
P1 Sch1	<p>MCZ-P2 Enabled activities</p> <p>Enable a range of activities that contribute positively to the purpose of the zone and meet sub-regional needs including:</p> <ol style="list-style-type: none"> 1. Commercial activities; 2. Residential activities; 3. Community facilities; 4. Educational facilities; 5. Arts, culture, and entertainment activities; 6. Marae activities; 7. Emergency service facilities; 8. Community corrections activities; 9. Visitor accommodation; 10. Recreational activities; 11. Repair and maintenance service activities; 12. Industrial activities; and 13. Public transport activities.
P1 Sch1	<p>MCZ-P3 Managed activities</p> <p>Manage the location and scale of commercial activities that could result in cumulative adverse effects on the viability and vibrancy of centres, the retention and establishment of a mix of activities within the Metropolitan Centre Zone, and the function of the transport network.</p>
P1 Sch1	<p>MCZ-P4 Potentially incompatible activities</p> <p>Only allow activities that are potentially incompatible with the purpose of the Metropolitan Centre Zone, where they will not have an adverse effect on the vibrancy and amenity values of the centre.</p> <p>Potentially incompatible activities include:</p> <ol style="list-style-type: none"> 1. Carparking visible at street edge along an active frontage or non-residential activity frontage; 2. Demolition of buildings that results in the creation of vacant land;

		<p>3. Ground floor residential activities on street edges identified as having an active frontage or non-residential activity frontage; and</p> <p>4. Yard-based retail activities.</p>
P1 Sch1	MCZ-P5	<p>Heavy industrial activities</p> <p>Avoid heavy industrial activities from locating in the Metropolitan Centre Zone.</p>
ISPP	MCZ-P6	<p>Housing choice</p> <p>Enable medium and high-density residential development that:</p> <ol style="list-style-type: none"> 1. Contributes towards accommodating anticipated growth in the City; and 2. Offers a range of housing price, type, size and tenure that is accessible to people of all ages, lifestyles, cultures, impairments and abilities.
ISPP	MCZ-P7	<p>Quality <u>development design</u> outcomes –neighbourhood and townscape outcomes</p> <p>Require new development, and alterations and additions to existing development at a site scale, to positively contribute to the sense of place, quality and amenity of the Metropolitan Centre Zone by:</p> <ol style="list-style-type: none"> 1. Meeting the requirements <u>Fulfilling the intent of the Centres and Mixed Use Design Guide as relevant;</u> 2. 1. Recognising the benefits of well-designed, comprehensive, development, including the extent to which the development: <ol style="list-style-type: none"> a. Acts as a positive catalyst for future change by reflecting <u>Reflects</u> the nature and scale of the development proposed enabled within the zone and in the vicinity; and responds to the evolving, more intensive identity of the centre; b. Optimises the development capacity of the land, particularly including sites that are: large, narrow, vacant or ground level parking areas; <ol style="list-style-type: none"> i. Large; or ii. Narrow; or iii. Vacant; or iv. Ground level parking areas; c. Provides for the increased levels of residential accommodation enabled in this zone; and d. Provides for a range of supporting business, open space and community facilities; e. <u>Is accessible for emergency service vehicles.</u> 3. 2. Ensuring that the development, where relevant: <ol style="list-style-type: none"> a. Responds to the site context, particularly where it is located adjacent to: <ol style="list-style-type: none"> i. A scheduled site of significance to tangata whenua or other Māori; ii. A heritage building, heritage structure or heritage area; iii. Residential zoned areas; iv. Open space zoned areas; b. Provides a safe and comfortable pedestrian environment; c. Enhances the quality of the streetscape and public / private interface;

		<ul style="list-style-type: none"> d. Integrates with existing and planned active and public transport movement networks; and e. Allows sufficient flexibility for ground floor space to be converted for a range of activities, including residential.
ISPP	MCZ-P8	<p>On-site residential amenity</p> <p>Achieve a good standard of amenity for residential activities in the Metropolitan Centre Zone by:</p> <ul style="list-style-type: none"> 1. Providing residents with access to adequate outlook; and 2. Ensuring convenient access to convenient outdoor space, including private and/or shared communal areas of outdoor space; 3. Meeting the requirements Fulfilling the intent of the Residential Centres and Mixed Use Design Guide, as relevant; and 4. Providing residents with adequate internal living space.
ISPP	MCZ-P9	<p>Managing adverse effects</p> <p>Recognise the evolving, higher density development context enabled anticipated in the Metropolitan Centre Zone, while managing any associated adverse effects including:</p> <ul style="list-style-type: none"> 1. Shading, privacy, bulk and dominance effects on adjacent sites; and 2. The impact of construction on the transport network and pedestrian linkages.
ISPP	MCZ-P10	<p>City outcomes contribution</p> <p>Require over height, large-scale residential, non-residential and comprehensive development in the Metropolitan Centre Zone to deliver City Outcomes Contributions as detailed and scored in Appendix 16 the Centres and Mixed Use Design Guide guideline G107, including through either satisfying least two of the following outcomes:</p> <ul style="list-style-type: none"> 1. Positively contributing to public space provision and the amenity of the site and surrounding area; and/or 2. Enabling universal accessibility within buildings ease of access for people of all ages and mobility; and/or 2. 3. Incorporating a level of building performance that leads to reduced carbon emissions and increased earthquake climate change resilience; and/or 3. 4. Incorporating construction materials that increase the lifespan and resilience of the development and reduce ongoing maintenance costs; and/or 4. 5. Incorporating assisted housing into the development; where this is provided, legal instruments are required to ensure that it remains assisted housing for at least 25 years; and/or 5. Enabling ease of access for people of all ages and mobility.

	MCZ-P11	<p>Retirement villages</p> <p><u>Provide for retirement villages where it can be demonstrated that the development:</u></p> <ol style="list-style-type: none"> <u>Fulfils the intent of the Residential Centres and Mixed Use Design Guide;</u> <u>Includes outdoor space that is sufficient to cater for the needs of the village;</u> <u>Provides an adequate and appropriately located area on site for the management, storage and collection of all of the solid waste, recycling and organic waste potentially generated by the development;</u> <u>Is able to be adequately serviced by three waters infrastructure or can address any constraints on the site; and</u> <u>Is of an intensity, scale and design that is consistent with the amenity values anticipated in the Zone.</u>
Rules: Land use activities		
P1 Sch1	MCZ-R1	Commercial activities
		<ol style="list-style-type: none"> Activity status: Permitted Where: <ol style="list-style-type: none"> The activity is not an Integrated Retail Activity (refer to Rule MCZ-R13).
P1 Sch1	MCZ-R2	Community facilities
		<ol style="list-style-type: none"> Activity status: Permitted
P1 Sch1	MCZ-R3	Educational facilities
		<ol style="list-style-type: none"> Activity status: Permitted
P1 Sch1	MCZ-R4	Arts, culture, and entertainment activities
		<ol style="list-style-type: none"> Activity status: Permitted
P1 Sch1	MCZ-R5	Marae activities
		<ol style="list-style-type: none"> Activity status: Permitted
P1 Sch1	MCZ-R6	Emergency service facilities
		<ol style="list-style-type: none"> Activity status: Permitted
P1 Sch1	MCZ-R7	Community corrections activities
		<ol style="list-style-type: none"> Activity status: Permitted
P1 Sch1	MCZ-R8	Visitor accommodation activities
		<ol style="list-style-type: none"> Activity status: Permitted

P1 Sch1	MCZ-R9	Recreation activities
1. Activity status: Permitted		
P1 Sch1	MCZ-R10	Repair and maintenance activities
1. Activity status: Permitted		
P1 Sch1	MCZ-R11	Public transport activities
1. Activity status: Permitted		
P1 Sch1	MCZ-R12	Residential activities
<p>1. Activity status: Permitted</p> <p>Where:</p> <p>a. The activity is located:</p> <ul style="list-style-type: none"> i. Above ground floor level; ii. At ground floor level along any street edge not identified as an active frontage; iii. At ground floor level along any street edge not identified as a non-residential activity frontage; iv. At ground level along any street not identified as requiring verandah coverage; or v. At ground level on any site contained within a Natural Hazard Overlay. 		
<p>2. Activity status: Discretionary</p> <p>Where:</p> <p>a. Compliance with the requirements of MCZ-R12.1 cannot be achieved.</p> <p>Notification status: An application for resource consent made in respect of rule MCZ-R12.2.a is precluded from being limited and publicly notified.</p>		
<p><u>2. Activity status: Restricted Discretionary</u></p> <p><u>Where:</u></p> <p><u>a. Compliance with the requirements of MCZ-R12.1.a cannot be achieved.</u></p> <p><u>Matters of discretion are:</u></p> <ol style="list-style-type: none"> <u>1. The matters in MCZ-P4, MCZ-P6 and MCZ-P7;</u> <u>2. The extent and effect of non-compliance with MCZ-S5 and MCZ-S6;</u> <u>3. Whether residential activities exceed 50% of the street frontage at ground floor;</u> <u>4. The extent to which an acceptable level of passive surveillance is maintained between the interior of the building and the street or area of public space;</u> <u>5. The extent to which the building frontage is designed and located to create a strong visual alignment with adjoining buildings;</u> <u>6. The effect on the visual quality of the streetscape and the extent to which the activity contributes to or detracts from the surrounding public space;</u> <u>7. The continuity of verandah coverage along the identified street, informal access route or public space; and</u> 		

8. The extent to which non-compliance with verandah coverage will adversely affect the comfort and convenience of pedestrians.

Notification status: An application for resource consent made in respect of rule MCZ-R12.2.a is precluded from being either publicly or limited notified.

P1 Sch1

MCZ-R13 Retirement Villages

1. Activity status: Permitted

P1 Sch1

MCZ-R1413 Integrated retail activity

1. Activity status: **Permitted**

~~Where:~~

~~a. The total gross floor area does not exceed 20,000m².~~

~~2. Activity status: **Restricted Discretionary**~~

~~Where:~~

~~a. Compliance with the requirements of MCZ-R13.1 cannot be achieved.~~

~~Matters of discretion are:~~

~~1. The matters in MCZ-P1, MCZ-P2, MCZ-P3, and MCZ-P4;~~

~~2. The cumulative effect of the development on:-~~

~~a. The ongoing viability and vibrancy of the City Centre Zone and Golden Mile;~~

~~b. a. The safety and efficiency of the transport network, including providing for a range of transport modes;~~

~~c. b. The hierarchy of roads, travel demand or vehicle use; and~~

~~3. The compatibility with other activities provided for in the Zone.~~

~~Council will not apply a permitted baseline assessment when considering the effects of integrated retail activities that cannot comply with MCZ-R13.1.a.~~

P1 Sch1

MCZ-R1544 Industrial activities

1. Activity status: **Permitted**

Where:

a. The activity is not a heavy industrial activity.

2. Activity Status: **Non-complying**

Where:

a. Compliance with the requirements of MCZ-R1544.1 cannot be achieved.

Notification status: An application for resource consent made in respect of rule MCZ-R1544.2.a must be publicly notified.

P1 Sch1	MCZ-R1645	Carparking activities
	<p>1. Activity status: Permitted</p> <p>Where:</p> <p>a. The activity involves:</p> <ul style="list-style-type: none"> i. Provision of carparks not visible at street edge along an active frontage or non-residential activity frontage; or ii. Provision of carparks above ground floor level; or iii. Provision of carparks below ground floor level; or iv. Provision of parking spaces for people with disabilities; or v. Provision of ground floor level carparks that form part of a building specifically constructed and used for carparking purposes-; <u>or</u> <u>vi. Provision of carparks on a road.</u> 	
	<p>2. Activity status: Discretionary</p> <p>Where:</p> <p>a. Compliance with the requirements of MCZ-R1645.1.a is not achieved.</p>	
P1 Sch1	MCZ-R1746	Yard-based retailing activities
	<p>1. Activity status: Discretionary</p> <p>Notification status: An application for resource consent made in respect of rule MCZ-R1746.1 <u>that is either a new activity or expands the net area of an existing activity</u> must be publicly notified. <u>except when:-</u></p> <p>a. <u>The activity relates to the maintenance, operation and upgrading of an existing activity.</u></p>	
P1 Sch1	MCZ-R1847	All other land use activities
	<p>1. Activity status: Discretionary</p> <p>Where:</p> <p>a. The activity is not otherwise provided for as a permitted activity, restricted discretionary activity, or a non-complying activity.</p>	
Rules: Building and structures activities		
ISPP	MCZ-R1948	Maintenance and repair of buildings and structures
	<p>1. Activity status: Permitted</p>	
ISPP	MCZ-R2049	Demolition or removal of buildings and structures
	<p>1. Activity status: Permitted</p> <p>Where:</p> <p>a. The demolition or removal of a building:</p> <ul style="list-style-type: none"> i. Is required to avoid an imminent threat to life and/or property; or 	

- ii. Enables the creation of public space ~~or private outdoor living space associated with the use of a building;~~ or
- iii. Is required for the purposes of constructing a new building or structure, or adding to or altering an existing building or structure, that is a permitted activity under MCZ-R1920 or DEV-R1, or that has an approved resource consent, or resource consent is being sought concurrently ~~under MCZ-R20.2, or for the Kilbirnie Bus Barns Development Area, DEV-R1.2;~~ or
- b. The building or structure for demolition or removal is not on a site that has an active frontage or non-residential activity frontage; or
- c. The demolition or removal involves a structure, excluding any building.

2. Activity status: **Discretionary**

Where:

- a. Compliance with any of the requirements of MCZ-R~~2019~~.1 cannot be achieved

The assessment of the activity must have regard to:

- 1. How the land will be utilised whilst it is vacant; and
- 2. Creating a positive visual relationship between the site and streetscape whilst the site is vacant.

Notification status: An application for resource consent made in respect of rule MCZ-R~~2019~~.2.a is precluded from being either publicly or limited notified.

ISPP

MCZ-R~~2120~~

Construction of, or additions and alterations to, buildings and structures

1. Activity status: **Permitted**

Where:

- a. ~~The Any~~ alterations or additions to a building or structure ~~that:~~
 - i. Do not alter ~~its the~~ external appearance ~~of the building or structure;~~ or
 - ii. ~~Involve the placement of solar panels on rooftops; or~~
 - iii. ~~Involve maintenance, repair or painting; or~~
 - iv. ~~Involve re-cladding with like for like materials and colours; or~~
 - v. Relate to a building frontage ~~that is:~~
 - ~~Below verandah level, including entranceways and glazing; and~~
 - ~~Compliant compliance~~ with MCZ-S5 ~~is achieved;~~ or
 - vi. Are not visible from public spaces; and
- b. ~~The alterations or additions:~~
 - i. ~~Do not~~ result in the creation of new residential units; and
 - ii. Comply with standards MCZ-S1, MCZ-S2, MCZ-S3, MCZ-S4, MCZ-S5, ~~and~~ MCZ-S6 ~~and MCZ-S12;~~ and
- c. ~~The~~ construction of any building or structure:
 - i. Is not located on a site with an active frontage or non-residential activity frontage; or
 - ii. Is not visible from public space; and
 - iii. Will have a gross floor area of less than 100m²; and
 - iv. Will result in a total coverage (together with other buildings) of no more than 20 percent of the site; and
 - v. ~~Will c~~Comply with standards MCZ-S1, MCZ-S2, MCZ-S3, MCZ-S4, MCZ-S5, ~~and~~ MCZ-S6 ~~and MCZ-S12;~~ and
 - vi. Does not involve the construction of a new building for residential activities.

2. Activity status: **Restricted Discretionary**

	<p>Where:</p> <p>a. compliance with any of the requirements of MCZ-R19.1<u>MCZ-R2120.1</u> cannot be achieved.</p> <p>Matters of discretion are:</p> <ol style="list-style-type: none"> 1. The matters in MCZ-P6, MCZ-P7, MCZ-P8, <u>and</u> MCZ-P9 <u>and</u> MCZ-P11; 2. The extent and effect of non-compliance with MCZ-S1, MCZ-S2, MCZ-S3, MCZ-S4, MCZ-S5, MCZ-S6, MCZ-S7, MCZ-S8, MCZ-S9, MCZ-S10, <u>and</u> MCZ-S11 <u>and</u> MCZ-S12; 3. City Outcomes Contribution The Centres and Mixed-Use Design Guide, including guideline G107 – City Outcomes Contribution as required in Appendix 16 for any building that exceeds the maximum height requirement and either comprises 25 or more residential units or is a non-residential building; 4. The Residential Design Guide; <u>3.</u> The extent and effect of any identifiable site constraints; <u>4.</u> Construction impacts on the transport network; and <u>5.</u> The availability and connection to existing or planned three waters infrastructure. <p>Notification status:</p> <p><u>An application for resource consent made in respect of rule MCZ-R2120.2.a that complies with all standards is precluded from being either publicly or limited notified.</u></p> <p>Notification status: An application for resource consent made in respect of rule MCZ-R2120.2<u>2120.2</u> which complies with MCZ-S3, MCZ-S7, MCZ-S8, MCZ-S9, MCZ-S10 and MCZ-S11 is precluded from being either publicly or limited notified.</p> <p>Notification status: An application for resource consent made in respect of rule MCZ-R2120.2<u>2120.2</u> which results from non-compliance with MCZ-S1, MCZ-S2, MCZ-S4, MCZ-S5, <u>and</u> MCZ-S6 <u>and</u> MCZ-S12 is precluded from being publicly notified.</p>				
	<p>3. <u>Activity status: Restricted Discretionary</u></p> <p><u>Where:</u></p> <p>a. <u>In addition to MCZ-R21.2, and as it relates to the construction of, or addition to, a building or structure, the relevant building height at MCZ-S1 is exceeded by more than 25%.</u></p> <p><u>Matters of discretion are:</u></p> <ol style="list-style-type: none"> 1. <u>The matters in MCZ-P10;</u> 2. <u>The application and implementation of the City Outcome Contribution as set out in Appendix 16.</u> <p><u>Notification status: An application for resource consent made in respect of rule MCZ-R21.3 is precluded from being either publicly or limited notified, except where the application does not satisfy the outcome threshold in MCZ-P10.</u></p>				
<p>P1 Sch1</p>	<table border="1"> <tr> <td data-bbox="351 1648 518 1742"> <p>MCZ-R2224</p> </td> <td data-bbox="518 1648 1477 1742"> <p>Conversion of buildings, or parts of buildings, to residential activities</p> </td> </tr> <tr> <td colspan="2" data-bbox="351 1742 1477 1973"> <p>1. Activity status: Restricted Discretionary</p> <p>Matters of discretion are:</p> <ol style="list-style-type: none"> 1. The matters in MCZ-P1, MCZ-P3, MCZ-S6, <u>and</u> MCZ-P8 <u>and</u> MCZ-P11; 2. The extent of compliance with standards MCZ-S7, MCZ-S8 and MCZ-S9 and satisfaction of associated assessment criteria; <u>and</u> </td> </tr> </table>	<p>MCZ-R2224</p>	<p>Conversion of buildings, or parts of buildings, to residential activities</p>	<p>1. Activity status: Restricted Discretionary</p> <p>Matters of discretion are:</p> <ol style="list-style-type: none"> 1. The matters in MCZ-P1, MCZ-P3, MCZ-S6, <u>and</u> MCZ-P8 <u>and</u> MCZ-P11; 2. The extent of compliance with standards MCZ-S7, MCZ-S8 and MCZ-S9 and satisfaction of associated assessment criteria; <u>and</u> 	
<p>MCZ-R2224</p>	<p>Conversion of buildings, or parts of buildings, to residential activities</p>				
<p>1. Activity status: Restricted Discretionary</p> <p>Matters of discretion are:</p> <ol style="list-style-type: none"> 1. The matters in MCZ-P1, MCZ-P3, MCZ-S6, <u>and</u> MCZ-P8 <u>and</u> MCZ-P11; 2. The extent of compliance with standards MCZ-S7, MCZ-S8 and MCZ-S9 and satisfaction of associated assessment criteria; <u>and</u> 					

~~3. The Residential Design Guide; and~~

4. 3. The availability and connection to existing or planned three waters infrastructure.

Notification status: An application for resource consent made in respect of rule MCZ-~~R2224~~.1 is precluded from being either publicly or limited notified.

P1 Sch1

MCZ-R~~2322~~ Outdoor storage areas

1. Activity status: **Permitted**

Where:

- a. The storage area is screened by either a fence or landscaping of 1.8m in height from any adjoining road or site.
- b. Screening does not obscure emergency or safety signage or obstruct access to emergency panels, hydrants, shut-off valves, or other emergency response facilities.

Standards

ISPP

MCZ-S1 Maximum height

1. The following maximum height limits above ground level must be complied with:

Location	Limit
Height control area 1 Johnsonville (<u>except as below</u>)	35m
Height control 2 Johnsonville, <u>34 Johnsonville Road (block bordered by Moorefield Road, Johnsonville Road and Broderick Road), and 91 Johnsonville Road</u>	<u>42m</u>
Height control 3 2 <u>Kilbirnie (except as below)</u>	<u>35m 27m</u>
Height control area 4 3 Kilbirnie, north of Rongotai Road	15m

Assessment criteria where the standard is infringed:

- 1. Streetscape and visual amenity effects;
- 2. Dominance, privacy and shading effects on adjoining sites; and
- 3. The extent to which taller buildings would contribute to a substantial increase in residential accommodation.

2. Fences and standalone walls must not exceed a maximum height of 1.8 metres (measured above ground level).

This standard does not apply to:

- a. Lot 2 DP 32689 (27 Johnsonville Road), where an 11m maximum height limit applies;
- b. Accessory buildings;

<ul style="list-style-type: none"> c. Solar panel and heating components attached to a building provided these do not exceed the height by more than 500mm; d. Satellite dishes, antennas, aerials, chimneys, flues, architectural or decorative features (e.g. finials, spires) provided that none of these exceed 1m in diameter and do not exceed the height by more than 1m; and e. Lift overruns provided these do not exceed the height by more than 4m. 	
---	--

ISPP

MCZ-S2	Minimum building height
---------------	--------------------------------

<p>1. A minimum height of 7m is required for:</p> <ul style="list-style-type: none"> a. New buildings or structures; and b. Additions to the frontages of existing buildings and structures. <p><u>This standard does not apply to:</u></p> <ul style="list-style-type: none"> 1. <u>Accessory buildings, ancillary to the primary activity on the site.</u> 2. Any building or structure that is unable to be occupied by people. 	<p>Assessment criteria where the standard is infringed;</p> <ul style="list-style-type: none"> 1. The extent to which a reduced height: <ul style="list-style-type: none"> a. Is necessary to provide for functional needs or operational needs of a proposed activity; 2. Whether topographical or other site constraints make compliance with the standard impracticable or unnecessary; and 3. Whether, for any additions or alterations, the existing ground floor height meets the standard.
--	--

ISPP

MCZ-S3	Minimum ground floor height
---------------	------------------------------------

<p>1. The minimum ground floor height to <u>the</u> underside of <u>a</u> structural slab or equivalent shall be 4m.</p>	<p>Assessment criteria where the standard is infringed:</p> <ul style="list-style-type: none"> 1. The extent to which a reduced height: <ul style="list-style-type: none"> a. Will compromise or preclude future use or adaptation of the ground floor for non-residential activities; b. Is necessary to provide for functional needs or operational needs of a proposed activity; and 2. Whether topographical or other site constraints make compliance with the standard impracticable or unnecessary.
--	---

ISPP

MCZ-S4	Height in relation to boundary
---------------	---------------------------------------

<p>1. No part of any building or structure may project beyond the relevant recession plane shown below:</p>	<p>Assessment criteria where the standard is infringed:</p> <ul style="list-style-type: none"> 1. Dominance, privacy, and shading effects on adjoining sites; 		
<table border="1" style="width: 100%;"> <tr> <td style="width: 50%; text-align: center;">Location</td> <td style="width: 50%; text-align: center;">Recession plane</td> </tr> </table>	Location	Recession plane	
Location	Recession plane		

Boundary adjoining any site within the MRZ with a height limit of 11m identified on the District Plan Maps	60° measured from a height of 4m vertically above ground level	2. Whether an increase in height in relation to boundary results from a response to natural hazard mitigation; 3. Effects on public spaces; and 4. The extent to which an increase in height in relation to boundary would contribute to a substantial increase in residential accommodation.
Boundary adjoining any site within the MRZ with a height limit of 14m identified on the District Plan Maps	60° measured from a height of 5m vertically above ground level	
Boundary adjoining any site within the HRZ	60° measured from a height of 8m vertically above ground level	
Boundary adjoining any site within an Open Space Zone	60° measured from a height of 5m vertically above ground level	

ISPP

MCZ-S5	Verandah control
---------------	-------------------------

<p>1. Verandahs must be provided on building elevations on identified street frontages.</p> <p>2. Any verandah must:</p> <ol style="list-style-type: none"> a. Extend the full width of the building elevation; b. Connect with any existing adjoining verandah; c. Have a minimum clearance of 2.5m directly above the footpath or formed ground surface; d. Not exceed a maximum height of 4m measured between the base of the verandah fascia and the footpath or formed ground surface directly below; e. Be setback a minimum of 450mm from any point along the kerbing extending back to the site boundary; and f. Not exceed a maximum width of 3m from the front of the building. <p>This standard does not apply to:</p> <ol style="list-style-type: none"> a. Any scheduled building identified in SCHED1-Heritage buildings. However, if for any reason these buildings received Council approval (resource consent or other approval) to be demolished, then a verandah would be required for any replacement buildings on these sites; and b. Any building where compliance with the standard results in an encroachment into the dripline of an existing street tree; c. Service stations. 	<p>Assessment criteria where the standard is infringed:</p> <ol style="list-style-type: none"> 1. The extent to which any non-compliance: <ol style="list-style-type: none"> a. Will adversely affect the comfort and convenience of pedestrians; b. Will result in further street trees being added to public space as part the development; and 2. The continuity of verandah coverage along the identified street, informal access route or public space.
---	---

ISPP

MCZ-S6	Active frontage and non-residential activity frontage controls
---------------	---

<p>1. Any new building or addition to an existing building facing adjoining an identified street with an active frontage must:</p> <ol style="list-style-type: none"> a. Be built up to the street edge <u>at ground floor level along at least 90% of the full width of the site that borders the street(s); on all street boundaries with an identified active frontage control and along the full width of the site bordering any street boundary;</u> b. Provide a minimum of 60% of continuous display windows or transparent glazing along the width of the ground floor building frontage; and c. Locate the principal public entrance on the front boundary; <p><u>This standard does not apply to:</u></p> <ol style="list-style-type: none"> a. <u>Any vehicle and pedestrian access to a site situated on a street subject to an active frontage or non-residential activity control;</u> b. <u>Service stations.</u> <p>2. Any ground level addition to, or alteration of, a building or structure facing a public space must not result in a featureless façade that:</p> <ol style="list-style-type: none"> a. Is more than 3 metres wide; and b. Extends from a height of 1m above ground level to a maximum height of 2.5m; <p>3. Any roller shutter doors, security grilles, screens or similar structures fitted to the facade of any building must be at least 50% visually transparent; and</p> <p>4. Any new building or addition to an existing building on a site with a non-residential activity frontage control must:</p> <ol style="list-style-type: none"> a. Be built up to the street edge on all street boundaries and along the full width of the site bordering any street boundary; and b. Locate the principal public entrance on the front boundary. 	<p>Assessment criteria where the standard is infringed:</p> <ol style="list-style-type: none"> 1. The extent to which: <ol style="list-style-type: none"> a. Any non-compliance is required for on-site functional needs or operational needs; b. The building frontage is designed and located to create a strong visual alignment with adjoining buildings <u>or otherwise enhances the streetscape;</u> and c. An acceptable level of passive surveillance is maintained between the interior of the building and the street.
--	---

ISPP

MCZ-S7	Minimum residential unit size
---------------	--------------------------------------

<p>1. Residential units, including dual-key units must meet the following minimum sizes:</p> <table border="1" style="width: 100%; border-collapse: collapse;"> <thead> <tr> <th style="width: 30%;">Residential unit type</th> <th style="width: 70%;">Minimum net floor area</th> </tr> </thead> <tbody> <tr> <td>a. Studio unit</td> <td>35m²</td> </tr> <tr> <td>b. 1 bedroom unit</td> <td>40m²</td> </tr> <tr> <td>c. 2+ bedroom unit</td> <td>55m²</td> </tr> </tbody> </table>	Residential unit type	Minimum net floor area	a. Studio unit	35m ²	b. 1 bedroom unit	40m ²	c. 2+ bedroom unit	55m ²	<p>Assessment criteria where the standard is infringed:</p> <ol style="list-style-type: none"> 1. The extent to which: <ol style="list-style-type: none"> a. The design of the proposed unit provides a good standard of amenity; and b. Other on-site factors compensate for a reduction in unit sizes.
Residential unit type	Minimum net floor area								
a. Studio unit	35m ²								
b. 1 bedroom unit	40m ²								
c. 2+ bedroom unit	55m ²								

ISPP

MCZ-S8		Residential – outdoor living space	
<ol style="list-style-type: none"> Each residential unit, including any dual key unit, must be provided with either a private outdoor living space or access to a communal outdoor living space; Where private outdoor living space is provided it must be: <ol style="list-style-type: none"> For the exclusive use of residents; Directly accessible from a habitable room; A single contiguous space; and Of the minimum area and dimension specified in the table below; and Where communal outdoor living space is provided it does not need to be in a single continuous space but it must be: <ol style="list-style-type: none"> Accessible from the residential units it serves; Of the minimum area and dimension specified in the table below; and Free of buildings, parking spaces, and servicing and manoeuvring areas. 		Assessment criteria where the standard is infringed: <ol style="list-style-type: none"> The extent to which: <ol style="list-style-type: none"> Any proposed outdoor living space provides a good standard of amenity relative to the number of occupants the space is designed for; Other on-site factors compensate for a reduction in the size or dimension of the outdoor living space; Whether any alternative publicly available open space adjoins or is in close proximity to the site; and The availability of public space in proximity to the site. 	
Living space type	Minimum area	Minimum dimension	
a. Private			
i. Studio unit and 1- bedroom unit	5m ²	1.8m	
ii. 2+ bedroom unit	8m ²	1.8m	
b. Communal			
i. For every 4 <u>15</u> units	4064 m ²	8m	
<u>For each additional unit above 15 units</u>	<u>2m²</u>	<u>-</u>	
<p><u>Note: Communal outdoor living space is calculated on the basis of the number of units without exclusive access to based on the number of units not provided with the minimum area of private outdoor living space.</u></p>			

ISPP

MCZ-S9		Minimum outlook space for multi-unit housing	
<ol style="list-style-type: none"> Every residential unit must be designed to achieve a minimum of 1m by 1m outlook space for all habitable rooms. <u>All principal living rooms must have an outlook space of a minimum dimension of 4m in depth</u> 		Assessment criteria where the standard is infringed: <ol style="list-style-type: none"> The extent to which; 	

and 4m in width as shown in Diagram X and Diagram X below.

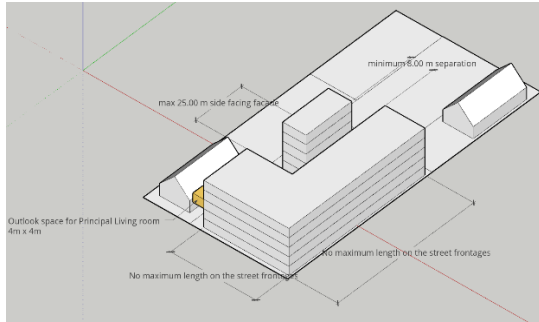
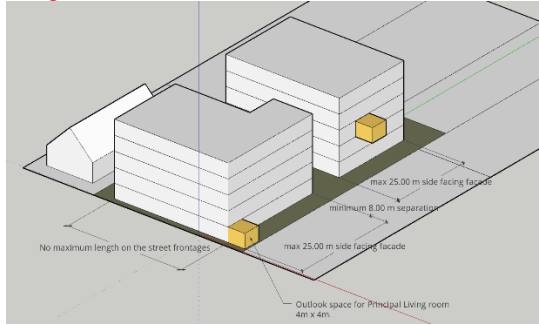

- a. The design of the proposed unit provides a good standard of amenity; and
- b. Other on-site factors compensate for a reduction in outlook space.

ISPP

MCZ-S10

Minimum building separation distance for residential activities

1. Any new building or addition to an existing building used for residential activities must provide an 8m separation distance between buildings located on the same site, as shown in Diagram 15 [and Diagram X](#) below.

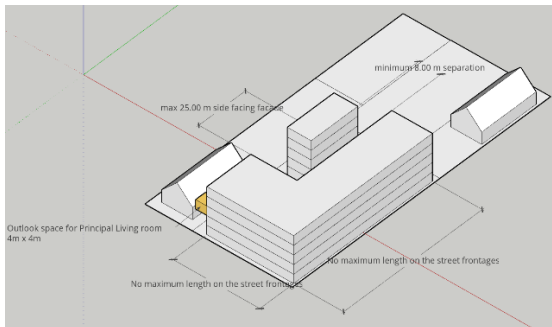
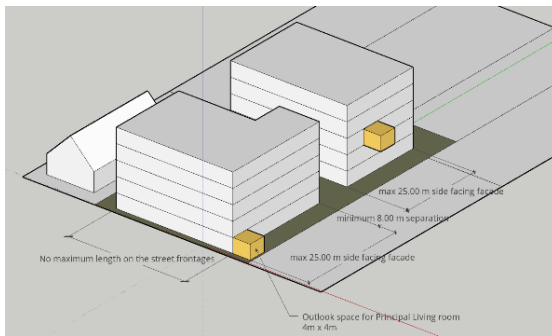
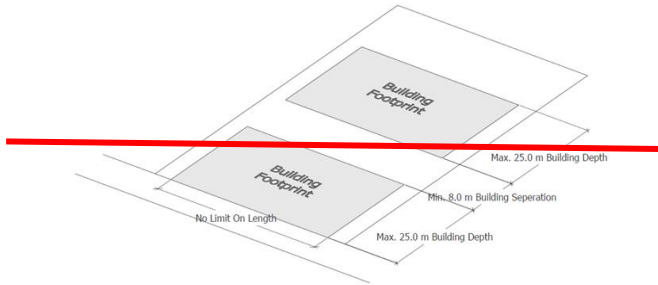

Assessment criteria where the standard is infringed:

1. The extent to which a reduced setback will increase dominance and shadowing related effects on residential units within the development site; and
2. Dominance, privacy and shading effects on adjoining sites.

ISPP

MCZ-S11

Maximum building depth [for residential activities](#)

~~1. Any new building or additions to existing buildings used for residential activities must not result in the continuous depth of any external side wall being greater than 25m, as shown in Diagram 14 below.~~

1. Any new building, part of a new building, or additions to an existing building, constructed for residential activities on any site aside from a rear site, must not result in the continuous length of any external side façade, facing a neighbouring site, being greater than 25m, as shown in Diagram 19 and Diagram X below.

Assessment criteria where the standard is infringed:

1. The extent to which design mitigates the effect of a long featureless building elevation;
2. Dominance, privacy and shading effects on adjoining sites.

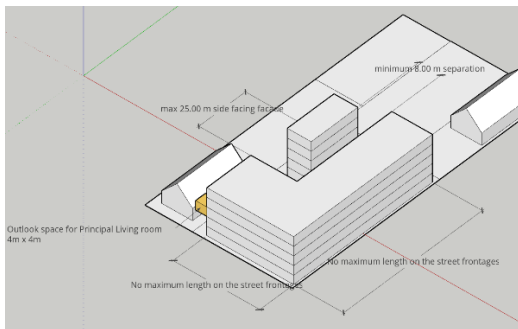
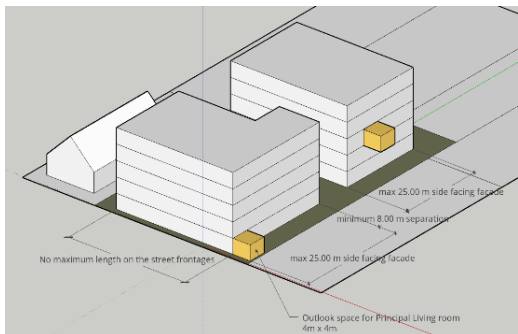
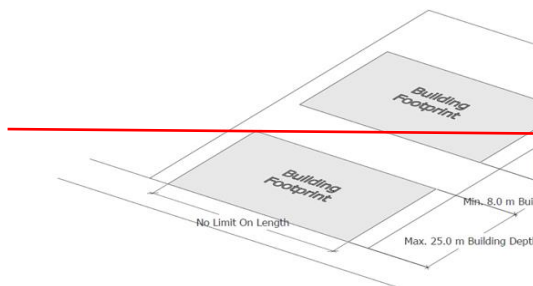

ISPP

<u>MCZ-S12</u>	<u>Boundary setback from rail corridor</u>	
<p>1. <u>Buildings or structures must not be located within 1.5m of the boundary of a designated rail corridor.</u></p>	<p><u>Assessment criteria where the standard is infringed:</u></p> <p>1. <u>The extent to which the location and design of the building relates to the ability to safely use, access and maintain buildings without requiring access on, above or over the rail corridor.</u></p>	
<u>Methods</u>		
<u>MCZ-M1</u>	<u>Urban Design Panel</u>	
<p><u>Subject to obtaining relevant approvals and supporting funding, Council will seek to establish and facilitate an independent Urban Design Panel to inform the urban design assessments of relevant policies and matters of discretion that apply to significant resource consent applications as required.</u></p>		

He Rohe Pokapū Tāone

City Centre Zone

CCZ	City Centre Zone
-----	------------------

P1 Sch1

Introduction

The purpose of the City Centre Zone is to enable and reinforce the continued primacy of the Wellington central city area as the principal commercial and employment centre servicing the city and metropolitan region. The City Centre Zone is the commercial heart of Wellington and the wider region and New Zealand's Capital City. It is also a major employment hub for the region and contains a vibrant and diverse mix of inner city living, entertainment, educational, government, [parliamentary, civic](#) and commercial activity. Relative to other areas of the city it exhibits a heightened intensity and scale of development.

As well as a diversity of activity, the City Centre Zone contains a variety of environments ranging from high-rise office towers and residential apartments through to distinct heritage areas and buildings, and an array of public and open space, including the waterfront. These combine to give the City Centre Zone a distinctive identity and character.

This distinctiveness is further reinforced by the long established traditional, historical, cultural, and spiritual associations and more recent development interests that the mana whenua of Te Whanganui ā Tara (Wellington), Taranaki Whānui and Ngāti Toa Rangatira, have with many places and sites across the City Centre Zone. Some of the more significant of these include Pipitea Marae and Pā, Kumutoto Kāinga and stream, Te Aro Kainga, Waitangi and Whairepo Lagoons and statutory acknowledgement areas such as the Old Government Buildings and Turnbull House Historic Reserves.

Also centrally located within the City Centre Zone is Te Ngākau Civic Square – a distinct civic precinct that abuts Victoria Street, Wakefield Street, Harris Street and Jervois Quay and acts as a key connector to the city's waterfront. The precinct is entering a phase of transition, with some of its associated civic buildings and assets requiring either earthquake strengthening or redevelopment. In addition to seismic resilience challenges it also faces significant climate and water management related issues including flooding and inundation.

A long-term vision for the Te Ngākau Civic Square Precinct has been developed and approved by the Council, the focus of which is ensuring the precinct becomes a vibrant, safe and inclusive area that enables creative, cultural, civic and arts activities to flourish. [The Council and its mana whenua partners will plan the precinct development to realise this vision.](#) The City Centre Zone aligns with this vision by enabling a level of redevelopment to occur that accommodates the range of activities anticipated.

To maximise development capacity to accommodate projected growth, an increase in the scale and intensity of development is enabled across the zone, [including through the removal of maximum building heights.](#) This includes building height, density and urban form tailored to align with the outcomes sought by the National Policy Statement – Urban Development (NPS-UD) and to reflect the higher, denser nature of development within the City Centre Zone. To complement this the Zone also contains measures to ensure that buildings and spaces are designed to:

- be of accessible and of a good quality;
- positively contribute to public space and built form of the City Centre;

- offer a suitable level of amenity for users such as access to sunlight and open space;
- provide opportunities for active and passive recreational pursuits; and
- mitigate relevant adverse effects.

To ensure the continued vibrancy ~~and viability~~ of the City Centre Zone a wide range of activities are permitted and encouraged throughout most parts of the Zone. This is supported by measures to manage activities and development that have the potential to adversely affect public and private amenity or to create reverse sensitivity effects, including along the boundary with adjoining residentially zoned areas or identified public space.

In locations where rapid transit investment has been signalled measures have been included to enable opportunities for more intensive, comprehensive development to occur, particularly in areas within a walkable ~~distance~~ catchment of planned rapid transit stops.

**CCZ-
PREC01**

Te Ngākau Civic Square Precinct

P1 Sch1

The purpose of the Te Ngākau Civic Square Precinct is to provide for civic activities ~~and~~, functions, ~~public use, and~~ areas of open space and redevelopment of the precinct while ensuring that any future development respects the special qualities of the area, including the concentration of ~~scheduled~~ heritage buildings.

The Precinct is Wellington's unique civic place. It is located in the heart of the City Centre and is a destination in itself. It is also an anchor point and gateway that connects the city centre's entertainment area, the waterfront and the Central Business District. Wellington's major civic and entertainment venues are located within the precinct, including the Wellington Town Hall, City Gallery Wellington (Te Whare Toi), Wellington City Library (Te Matapihi), Michael Fowler Centre, ~~Civic Administration Building, Municipal Office Building,~~ and Capital E.

The long-term vision for the precinct is that Te Ngākau is the beating heart of our capital city: a thriving neighbourhood where creativity, culture, democracy, discovery and arts experiences collide on the edge of Te Whānganui-a-Tara.

In particular, the aims of the Te Ngākau Civic Square Precinct are to:

1. Ensure that it is a vibrant and welcoming space which supports a range of uses to locate alongside its core civic function;
2. Provide a distinctive, safe, inclusive, comfortable and green environment for all users;
3. Create a civic space that reflects Wellington's unique culture, architecture, design, heritage and identity, including reflecting mana whenua values;
4. Ensure that future buildings and public environments are designed to a high quality; are resilient and sustainable; and complement and connect existing buildings and public spaces within the precinct as well as to the wider urban fabric of the City Centre;
5. Enable greater connectivity to surrounding streets and access between the city and waterfront, and to integrate with the wider transport network; and
6. Ensure that it is equipped to respond to significant seismic and climate change resilience challenges.

Te Ngākau Civic Square Precinct has long established historical and cultural associations for the mana whenua of Whanganui a Tara (Wellington), Taranaki Whānui and Ngati Toa Rangatira. Consequently, it is important that activities within the precinct recognise mana whenua as kaitiaki, alongside their relationship with the land. Active engagement with mana whenua will assist in ensuring the mouri/mauri of this area of significance to mana whenua is not diminished through any potential adverse effects created by activities and development within the precinct.

The Land Use Activities Rules for the City Centre Zone apply to the Te Ngākau Civic Square Precinct, with the Building and Structure Activity Rules and Standards for the City Centre Zone also applicable in addition to any precinct specific rules and standards identified in the plan.

Where there is any conflict between City Centre Zone and precinct specific provisions, the precinct provisions prevail.

Other relevant District Plan provisions

There may be a number of provisions that apply to an activity, building, structure or site. Resource consent may therefore be required under rules in this chapter as well as other chapters. Unless specifically stated in a rule, resource consent is required under each relevant rule. The steps to determine the status of an activity are set out in the General Approach chapter.

Objectives

City Centre Zone

ISPP

CCZ-01

Purpose

The City Centre Zone continues to be the primary commercial and employment centre servicing Wellington and the wider region, supported by residential and a diverse mix of other compatible activities that reflect its role and function in the hierarchy of centres.

ISPP

CCZ-02

Accommodating growth

The City Centre Zone plays a significant role in accommodating residential, business and supporting community service growth, and has sufficient serviced development capacity and additional infrastructure to meet its short, medium and long term residential and business growth needs, including:

1. A choice variety of building type, size, affordability and distribution, including forms of medium and high-density housing;
2. Convenient access to active and public transport activity options;
3. Efficient, well integrated and strategic use of available development sites; and
4. Convenient access to a range of open space, including green space, and supporting commercial activity and community facility options.

ISPP

CCZ-03

Urban form and scale

The scale and form of development in the City Centre Zone reflects its purpose as Wellington's primary commercial and employment centre, with the highest and most intensive form of development concentrated in the zone relative to other parts of the city.

ISPP

CCZ-04

Ahi Kā

Taranaki Whānui and Ngāti Toa Rangatira are acknowledged as the mana whenua of Te Whanganui ā Tara (Wellington) and their cultural associations, and landowner and development interests are recognised in planning and developing the City Centre Zone.

ISPP	CCZ-05	<p>Amenity and design</p> <p>Development in the City Centre Zone positively contributes to creating a high quality, well-functioning urban environment, including:</p> <ol style="list-style-type: none"> 1. Reinforcing the City Centre Zone’s distinctive sense of place; 2. Providing a quality and level of public and private amenity in the City Centre Zone that evolves and positively responds to anticipated growth and the diverse and changing needs of residents, businesses and visitors; 3. Maintaining and enhancing the amenity and safety of public space; 4. Contributing to the general amenity of neighbouring residential areas <u>while achieving the planned urban form of the City Centre Zone</u>; 5. Producing a resilient urban environment that effectively adapts and responds to natural hazard risks and the effects of climate change; 6. Protecting current areas of open space, including green space, and providing greater choice of space for residents, workers and visitors to enjoy, recreate and shelter from the weather; and 7. Acknowledging and sensitively responding to adjoining heritage buildings, heritage areas and areas and sites of significance to Māori.
ISPP	CCZ-06	<p>Development near rapid transit</p> <p>Activities and development near existing and planned rapid transit stops:</p> <ol style="list-style-type: none"> 1. Are located to enable convenient access by local residents, workers and visitors, particularly around transport hubs; 2. Are of sufficient residential scale and intensity to support a frequent and rapid transit network and associated mixed use development; and 3. Provide vibrant, attractive and easily accessible public space.
ISPP	CCZ-07	<p>Managing adverse effects</p> <p>Adverse effects of activities and development in the City Centre Zone are managed effectively both:</p> <ol style="list-style-type: none"> 1. Within the City Centre Zone; and 2. At interfaces with: <ol style="list-style-type: none"> a. Heritage buildings, heritage structures and heritage areas; b. Scheduled sites and areas of significance to Māori; c. Identified public spaces; d. Identified pedestrian streets; e. Residential Zoned areas; f. Open Space and Recreation Zoned areas; and g. The Waterfront Zone.
Te Ngākau Civic Square Precinct		
ISPP	CCZ- PREC <u>01</u> -O1	<p>Purpose</p> <p>Te Ngākau Civic Square Precinct is a vibrant, safe, resilient, connected and inclusive environment supported by a range of activities that complement its primary civic function.</p>

ISPP	<p>CCZ-<u>PREC01-O2</u></p>	<p>Built form</p> <p>The scale, form and positioning of development within the Te Ngākau Civic Square Precinct:</p> <ol style="list-style-type: none"> 1. Respects and reinforces the distinctive form and scale of existing associated historic heritage buildings, architecture and public space; 2. Integrates mana whenua values into the design; 3. Frames the square, <u>where relevant</u>; 4. Ensures a high degree of sunlight access is achieved within the precinct <u>public spaces in the precinct</u>; 5. Provides multiple connections which enable people to conveniently move between the city centre and the waterfront; and 6. Is sustainable and resilient; and 7. <u>Provides for green spaces, where possible.</u>
ISPP	<p>CCZ-<u>PREC01-O3</u></p>	<p>Integration with the City Centre, Waterfront and wider transport network</p> <p>Safe and accessible pedestrian linkages through the Te Ngākau Civic Square Precinct, and to and from other parts of the city centre and waterfront, are maintained and enhanced.</p>
<p>Policies</p>		
<p>City Centre Zone</p>		
P1 Sch1	<p>CCZ-P1</p>	<p>Enabled activities</p> <p>Enable a range and diversity of activities that support the purpose and ongoing viability of the City Centre Zone and enhances its vibrancy and amenity, including:</p> <ol style="list-style-type: none"> 1. Commercial activities; 2. Residential activities, except located; <ol style="list-style-type: none"> a. <u>Above ground level; or</u> b. At ground level aAlong any street not subject to active frontage and/or verandah coverage requirements; ; c. On any site subject to an identified natural hazard risk; 3. Community facilities; 4. Educational facilities; 5. Arts, culture and entertainment activities; 6. Emergency service facilities; 7. Marae activities; 8. Community corrections activities; 9. Public transport activities; 10. Visitor accommodation; 11. Repair and maintenance service activities; and 12. Recreation activities; ; 13. <u>Parliamentary activities;</u> 14. <u>Government activities; and</u> 15. <u>Civic activities.</u>
P1 Sch1	<p>CCZ-P2</p>	<p>Potentially incompatible activities</p>

		<p>Only allow activities that are potentially incompatible with the purpose of the City Centre Zone, where they will not have an adverse effect on its vitality, vibrancy, and amenity, <u>resilience and accessibility</u>. Potentially incompatible activities include:</p> <ol style="list-style-type: none"> 1. Industrial activities; 2. Yard-based retail activities; 3. Carparking at ground level; 4. Demolition of buildings that results in the creation of vacant land; and 5. Ground floor residential activities on streets identified as requiring either an active frontage or verandah coverage and sites subject to an identified hazard risk.
P1 Sch1	CCZ-P3	<p>Heavy industrial activities</p> <p>Avoid heavy industrial activities from locating in the City Centre Zone.</p>
ISPP	CCZ-P4	<p>Housing choice</p> <p>Enable high density, good quality residential development that:</p> <ol style="list-style-type: none"> 1. Contributes towards accommodating anticipated growth in the city; and 2. Offers <u>Contributes to</u> a range of housing price, type, size and tenure that is accessible to people of all ages, lifestyles, cultures, <u>impairments</u> and abilities.
ISPP	CCZ-P5	<p>Urban form and scale</p> <p>Recognise the benefits of intensification by:</p> <ol style="list-style-type: none"> 1. Enabling greater overall height and scale of development to occur in the City Centre Zone relative to other centres; and 2. Requiring the available development capacity of land within the zone to be efficiently optimised.
ISPP	CCZ-P6	<p>Adaptive use</p> <p>Encourage new development and redevelopment in the City Centre Zone that is sustainable, resilient and adaptable to change in use over time, including enabling:</p> <ol style="list-style-type: none"> 1. Sufficient flexibility for ground floor space to be used and converted for a range of activities; and 2. Residential activities at ground floor level along streets that are not subject to active frontage and/or verandah coverage requirements and sites free of any identified natural hazard risk.
P1 Sch1	CCZ-P7	<p>Ahi Kā</p> <p>Recognise and enable Taranaki Whānui and Ngāti Toa Rangatira cultural associations and landowner and development interests in the City Centre Zone by:</p> <ol style="list-style-type: none"> 1. Providing for the development of papakāinga, kaumātua housing and affordable Māori housing on their landholdings;

	<ol style="list-style-type: none"> 2. Managing new development adjoining scheduled sites of significance to Māori; and 3. Collaborating on the design and incorporation of traditional cultural elements into public space within the zone.
<p>ISPP</p>	<p>CCZ-P8 Sense of place</p> <p>Provide for good quality new development and supporting public space that reinforces the City Centre’s identity and unique sense of place at a city scale, including its:</p> <ol style="list-style-type: none"> 1. Surrounding topography and harbour setting; 2. Rich Māori and tauīwi/non-Māori history; 3. Compact, walkable city structure; 4. Diversified and vibrant mix of activities; 5. Visually prominent buildings and variety of architectural styles; and 6. Diversity of accessible, well designed civic and public space.
<p>ISPP</p>	<p>CCZ-P9 Quality design development outcomes</p> <p>Require new development, and alterations and additions to existing development, at a site scale to positively contribute to the sense of place and distinctive form, quality and amenity of the City Centre Zone by:</p> <ol style="list-style-type: none"> 1. <u>Fulfilling the intent of the Centres and Mixed Use Design Guide:</u> 2. Recognising the benefits of well-designed, comprehensive development, including the extent to which the development: <ol style="list-style-type: none"> a. Acts as a catalyst for future change by reflecting <u>Reflects</u> the nature and scale of the development proposed <u>enabled</u> within the zone and in the vicinity and responds to the evolving, more intensive identity of the neighbourhood; b. Optimises the development capacity of the land, <u>particularly including</u> sites that are large, narrow, vacant or ground level parking areas; <ol style="list-style-type: none"> i. Large; or ii. Narrow; or iii. Vacant; or iv. Ground level parking areas; c. Provides for the increased levels of residential accommodation anticipated; and d. Provides for a range of supporting business, open space and community facilities; and e. <u>Is accessible for emergency service vehicles; and</u> 2. Ensuring that development, where relevant: <ol style="list-style-type: none"> a. Responds to the site context, particularly where it is located adjacent to: <ol style="list-style-type: none"> i. A scheduled site of significance to Māori;

	<ul style="list-style-type: none"> ii. A heritage building, heritage structure or heritage area; iii. An identified character precinct; iv. A listed public space; v. Identified pedestrian streets; vi. Residential zones; vii. Open space zones; and viii. The Waterfront Zone; <ul style="list-style-type: none"> b. Responds to the pedestrian scale of narrower streets; c. Responds to any identified significant natural hazard risks and climate change effects, including the strengthening and adaptive reuse of existing buildings; d. Provides a safe and comfortable pedestrian environment; e. Enhances the quality of the streetscape and the private/public interface; f. Integrates with existing and planned active and public transport activity movement networks, including planned rapid transit stops; and g. Allows sufficient flexibility for ground floor space to be converted to a range of activities, including residential along streets that are not subject to active frontage and/or verandah coverage requirements and sites free of any identified natural hazard risk.
<p>ISPP</p>	<p>CCZ-P10 On-site residential amenity</p> <p>Achieve a high standard of amenity for residential activities that reflects and responds to the evolving, higher density scale of development anticipated in the City Centre Zone, including:</p> <ul style="list-style-type: none"> 1. Providing residents with access to an adequate outlook; and 2. Ensuring <u>convenient</u> access to convenient outdoor space, including private and/or shared communal areas of outdoor space; <u>3. Fulfilling the intent of the Centres and Mixed Use Design Guide; and</u> <u>4. Providing residents with adequate internal living space.</u>
<p>ISPP</p>	<p>CCZ-P11 City outcomes contribution</p> <p>Require over and under height, large-scale residential, non-residential and comprehensive developments <u>over CCZ-S1 height thresholds and under CCZ-S4 minimum building heights</u> in the City Centre Zone to deliver City Outcomes Contributions as detailed and scored in <u>Appendix 16 the Centres and Mixed Use Design Guide guideline G107</u>, including <u>satisfying through at least two of the following outcomes either:</u></p>

ISPP

	<ol style="list-style-type: none"> 1. Positively contributing to public space provision and the amenity of the site and surrounding area; and/or 2. Enabling universal accessibility within buildings ease of access for people of all ages and mobility/disability; and/or 3. 3. Incorporating a level of building performance that leads to reduced carbon emissions and increased climate-change <u>earthquake</u> resilience; and/or 3. 4. Incorporating construction materials that increase the lifespan and resilience of the development and reduce ongoing maintenance costs; and/or 4. 5. Incorporating assisted housing into the development; where this is provided, legal instruments are required to ensure that it remains assisted housing for at least 25 years; and/or 5. Enabling ease of access for people of all ages and mobility.
<p>CCZ-P12</p>	<p>Managing adverse effects</p> <p>Recognise the evolving, higher density development context anticipated <u>enabled</u> in the City Centre Zone, while managing any associated adverse effects including:</p> <ol style="list-style-type: none"> 1. The impacts of building dominance and the height and scale relationship; 2. Building mass effects, including the amount of light and outlook around buildings; and 3. The impacts on sunlight access to identified public space; and 4. The impacts of related construction activity on the transport network <u>and pedestrian linkages</u>.
<p><u>CCZ-P13</u></p>	<p><u>Retirement villages</u></p> <p><u>Provide for retirement villages where it can be demonstrated that the development:</u></p> <ol style="list-style-type: none"> 1. <u>Fulfils the intent of the Centres and Mixed Use Design Guide;</u> 2. <u>Includes outdoor space that is sufficient to cater for the needs of residents;</u> 3. <u>Provides an adequate and appropriately located area on site for the management, storage and collection of all of the solid waste, recycling and organic waste potentially generated by the development;</u> 4. <u>Is able to be adequately serviced by three waters infrastructure or can address any constraints on the site; and</u> 5. <u>Is of an intensity, scale and design that is consistent with the amenity values anticipated in the Zone.</u>

Te Ngākau Civic Square Precinct

P1 Sch1

<p>CCZ- PREC01-P1</p>	<p>Activities</p>
----------------------------------	--------------------------

	<p>Enable a range of activities and temporary events that support the civic purpose and ongoing vibrancy and amenity of Te Ngākau Civic Square Precinct, including:</p> <ol style="list-style-type: none"> 1. Civic functions; 2. Arts, culture and entertainment activities; 3. Recreation activities; 4. Community facilities; 5. Commercial activities; and 6. Residential activities above ground level to encourage activation of the precinct both day and night.
ISPP	<p>CCZ- PREC01-P2</p> <p>Use and development of the Te Ngākau Civic Square Precinct</p> <p>Provide for the staged redevelopment of the Te Ngākau Civic Square Precinct, and its connections with the transport network, wider City Centre Zone and Waterfront Zone, including:</p> <ol style="list-style-type: none"> 1. Enhancing the public function, pedestrian network and public spaces within the precinct; 2. Maintaining its special character by managing the form, scale and intensity of development; 3. Ensuring land use activities and development are planned and designed in a co-ordinated, site-responsive, comprehensive and integrated manner; and 4. Enabling new development and a range of activities that are integrated and compatible with existing buildings and land uses in the precinct.
ISPP	<p>CCZ- PREC01-P3</p> <p>Access, connections and open space</p> <p>Require that the use and development of the Te Ngākau Civic Square Precinct:</p> <ol style="list-style-type: none"> 1. Provides attractive, safe, efficient, and convenient connections to existing and planned transport networks; 2. Promotes existing and planned pedestrian access and connections between the precinct, the waterfront and the city centre; and 3. Provides well-designed, safe and accessible public and green open space, within the precinct.
ISPP	<p>CCZ- PREC01-P4</p> <p>Amenity and design</p> <p>Require development within the Te Ngākau Civic Square Precinct to contribute positively to its visual quality, amenity, interest and public safety by:</p> <p><u>1. Fulfilling the intent of the Centres and Mixed Use Design Guide;</u></p> <p>4. <u>2.</u> Requiring buildings and public spaces to incorporate high-quality visual and architectural design based on factors such as the bulk, form, scale, portion, location and detailing of the building/structure or building additions/alterations;</p> <p>2.3. <u>3.</u> Ensuring building design respects the form, scale and style of heritage buildings and wider architectural elements within the precinct, including interface treatment with the Town Hall;</p> <p>3.4. <u>4.</u> Responding to any identified significant natural hazard risks and climate change effects, including the strengthening and adaptive reuse</p>

	<p>of existing buildings and requiring new buildings to be resiliently designed;</p> <p>4. <u>5.</u> Recognising mana whenua cultural values in the design of public spaces;</p> <p>5. <u>6.</u> Ensuring new development will result in overall improvements to the function, access and safety of the precinct, including enabling universal access and opportunities for formal and informal surveillance;</p> <p>6. <u>7.</u> Providing an active edge along a portion of each building that addresses both the internal precinct area and externally towards adjoining streets;</p> <p>7. <u>8.</u> Providing a comfortable micro-climate for precinct users;</p> <p>8. <u>9.</u> Positioning new development and managing building height and form to ensure a high degree of sunlight access is achieved within the square;</p> <p>9. <u>10.</u> Retaining and enhancing strong visual and physical connections between the square, the waterfront, the city centre and streets surrounding the precinct; and</p> <p>10. <u>11.</u> Incorporating public amenities, public artwork and means to assist wayfinding, including provision of interpretation and references to the area's cultural and historic heritage associations.</p>
--	--

Rules: Land use activities in the City Centre Zone

P1 Sch1

CCZ-R1	Commercial activities
---------------	------------------------------

1. Activity status: **Permitted**

P1 Sch1

CCZ-R2	Community facilities
---------------	-----------------------------

1. Activity status: **Permitted**

P1 Sch1

CCZ-R3	Educational facilities
---------------	-------------------------------

1. Activity status: **Permitted**

P1 Sch1

CCZ-R4	Recreation activities
---------------	------------------------------

1. Activity status: **Permitted**

P1 Sch1

CCZ-R5	Arts, culture, and entertainment activities
---------------	--

1. Activity status: **Permitted**

P1 Sch1

CCZ-R6	Emergency service facilities
---------------	-------------------------------------

1. Activity status: **Permitted**

P1 Sch1

CCZ-R7	Marae activities
---------------	-------------------------

1. Activity status: **Permitted**

P1 Sch1

CCZ-R8	Community corrections activities
---------------	---

	1. Activity status: Permitted	
P1 Sch1	CCZ-R9	Public transport activities
	1. Activity status: Permitted	
P1 Sch1	CCZ-R10	Visitor accommodation activities
	1. Activity status: Permitted	
P1 Sch1	CCZ-R11	Repair and maintenance service activities
	1. Activity status: Permitted	
P1 Sch1	CCZ-R12	Parliamentary activities
	1. <u>Activity status: Permitted</u>	
P1 Sch1	CCZ-R13	Government activities
	1. <u>Activity status: Permitted</u>	
P1 Sch1	CCZ-R14	Civic activities
	1. <u>Activity status: Permitted</u>	
P1 Sch1	CCZ-R15	Retirement Villages
	1. <u>Activity status: Permitted</u>	
P1 Sch1	CCZ-R16	Residential activities
	1. Activity status: Permitted	
	Where:	
	a. The activity is located:	
	i. Above ground floor level; or	
	ii. At ground floor level along any street edge not identified as an active frontage; or	
	iii. At ground level along any street not identified as requiring verandah coverage; or	
	iv. At ground level on any site contained within a Natural Hazard Overlay.	
	2. Activity status: Discretionary	
	Where:	
	a. Compliance with the requirements of CCZ-R12.1.a cannot be achieved.	
	Notification status: An application for resource consent made in respect of rule CCZ-R12.2.a is precluded from being either publicly or limited notified.	

<p>2. Activity status: <u>Restricted Discretionary</u></p> <p><u>Where:</u></p> <p><u>a. Compliance with the requirements of CCZ-R16.1.a cannot be achieved.</u></p> <p><u>Matters of discretion are:</u></p> <ol style="list-style-type: none"> <u>1. The matters in CCZ-P2, CCZ-P4 and CCZ-P9;</u> <u>2. The extent and effect of non-compliance with CCZ-S7 and CCZ-S8;</u> <u>3. Whether residential activities exceed 50% of the street frontage at ground floor;</u> <u>4. The extent to which an acceptable level of passive surveillance is maintained between the interior of the building and the street or area of public space;</u> <u>5. The extent to which the building frontage is designed and located to create a strong visual alignment with adjoining buildings;</u> <u>6. The effect on the visual quality of the streetscape and the extent to which the activity contributes to or detracts from the surrounding public space;</u> <u>7. The continuity of verandah coverage along the identified street, informal access route or public space; and</u> <u>8. The extent to which non-compliance with verandah coverage will adversely affect the comfort and convenience of pedestrians.</u> <p><u>Notification status: An application for resource consent made in respect of rule CCZ-R16.2.a is precluded from being either publicly or limited notified.</u></p>

P1 Sch1

CCZ-R1743	Industrial activities, excluding repair and maintenance service activities
------------------	---

<p>1. Activity status: Restricted Discretionary</p> <p>Where:</p> <p style="padding-left: 40px;">a. The activity is not a Heavy Industrial Activity.</p> <p>Matters of discretion are:</p> <ol style="list-style-type: none"> 1. The compatibility with, and nature and form of, neighbouring activities; 2. The effect on the visual quality of the streetscape and the extent to which the activity contributes to or detracts from the surrounding public space; and 3. Effects on the amenity of the area, particularly in relation to noise, traffic generation, dust, odour and light spill. <p>Notification status: An application for resource consent made in respect of rule CCZ-R1743.1.a is precluded from being publicly notified.</p>
<p>2. Activity status: Non-complying</p> <p>Where:</p> <p style="padding-left: 40px;">a. Compliance with the requirements of CCZ-R1743.1.a cannot be achieved</p>

	Notification status: An application for resource consent made in respect of rule CCZ-R 1743 .2 must be publicly notified.	
P1 Sch1	CCZ-R1844	Carparking activities
	<p>1. Activity status: Permitted</p> <p>Where:</p> <p>a. The activity involves:</p> <ul style="list-style-type: none"> i. Provision of carpark above ground floor level; or ii. Provision of carpark below ground floor level; or iii. Provision of parking spaces for people with disabilities; or iv. Provision of ground floor level carpark that form part of a building specifically constructed and used for carparking purposes <u>and that complies with CCZ-S8; or</u> v. <u>Provision of ground floor level carpark that form part of a building, are located to the rear of the site, comply with CCZ-S8 and are not visible from the street; or</u> vi. <u>Provision of carpark on a road.</u> 	
	<p>2. Activity status: Discretionary</p> <p>Where:</p> <p>a. Compliance with the requirements of CCZ-R1844.1.a cannot be achieved.</p> <p>Notification status: An application for resource consent made in respect of rule CCZ-R1844.2.a must be publicly notified.</p>	
P1 Sch1	CCZ-R1945	Yard-based retailing activities
	<p>1. Activity status: Discretionary</p> <p>Notification Status: An application for resource consent made in respect of rule CCZ-R1945 <u>that is either a new activity or expands the net area of an existing activity</u> must be publicly notified.</p>	
P1 Sch1	CCZ-R2046	All other land use activities
	<p>1. Activity status: Discretionary</p> <p>Where:</p> <p>a. The activity is not otherwise provided for as a permitted activity, restricted discretionary activity, or a non-complying activity.</p>	
Rules: Land use activities in the Te Ngākau Civic Square Precinct		
P1 Sch1	CCZ- PREC01-R1	Civic activities
	<p>1. Activity status: Permitted</p>	

P1 Sch1	CCZ- PREC01-R2	Arts, culture, and entertainment activities
	1. Activity status: Permitted	
P1 Sch1	CCZ- PREC01-R3	Community activities
	1. Activity status: Permitted	
P1 Sch1	CCZ- PREC01-R4	Commercial facilities
	1. Activity status: Permitted	
P1 Sch1	CCZ- PREC01-R5	Recreation activities
	1. Activity status: Permitted	
P1 Sch1	CCZ- PREC01-R6	Residential activities
	1. Activity status: Permitted Where: a. The activity is located above ground floor level.	
<u>P1 Sch1</u>	<u>CCZ- PREC01-R7</u>	<u>Educational facilities</u>
	1. <u>Activity status: Permitted</u>	
<u>P1 Sch1</u>	<u>CCZ- PREC01-R8</u>	<u>Government activities</u>
	1. <u>Activity status: Permitted</u>	
P1 Sch1	CCZ- PREC01- R97	All other land use activities
	1. Activity status: Discretionary Where: a. The activity is not otherwise provided for as a permitted activity, restricted discretionary activity, or a non-complying activity.	
Rules: Building and structure activities in the City Centre Zone		

ISPP	CCZ-R 2147	Maintenance and repair of buildings and structures
1. Activity status: Permitted		
ISPP	CCZ-R 2248	Demolition or removal of buildings and structures
1. Activity status: Permitted		
Where:		
<p>a. The demolition or removal of a building:</p> <ol style="list-style-type: none"> i. Is required to avoid an imminent threat to life and/or property; or ii. Enables the creation of public space or private outdoor living space associated with the use of a building; or iii. Is required for the purposes of constructing a new building or adding to or altering an existing building that <u>is a permitted activity under CCZ-R23 or CCZ-R24, or that</u> has an approved resource consent or resource consent is being sought concurrently under CCZ-R19.2, CCZ-R20.2 or CCZ-R20.3; or <p>b. The demolition or removal involves a structure, excluding any building.</p>		
2. Activity status: Non-complying		
Where:		
a. Compliance with any of the requirements of CCZ-R 2248 .1 cannot be achieved.		
Notification status: An application for resource consent made in respect of rule CCZ-R 2248 .2.a is precluded from being either publicly or limited notified.		
ISPP	CCZ-R 2349	Alterations and additions to buildings and structures
1. Activity status: Permitted		
Where:		
<p>a. The Any alterations or additions to a building or structure that:</p> <ol style="list-style-type: none"> i. Do not alter its the external appearance of the building or structure; or ii. Involve the placement of solar panels on rooftops; or iii. Involve maintenance, repair or painting; or iv. Involve re-cladding with like for like materials and colours; or v. Relate to a building frontage that is: <ul style="list-style-type: none"> • below verandah level, including entranceways and glazing; and • compliantes with CCZ-S8 is achieved; or vi. Are not visible from a public space; and <p>b. The alterations or additions:</p> <ol style="list-style-type: none"> iii-i_d Do not result in the creation of new residential units; and iv. Are not visible from public spaces; and ii. Comply with standards <u>CCZ-S1, CCZ-S2, CCZ-S3, CCZ-S4, CCZ-S5, CCZ-S6, CCZ-S7, and CCZ-S8, CCZ-S15 and CCZ-S16.</u> 		

ISPP	<p>2. Activity status: Restricted Discretionary</p> <p>Where:</p> <p>a. Compliance with any of the requirements of CCZ-R2349.1 cannot be achieved.</p> <p>Matters of discretion are:</p> <ol style="list-style-type: none"> 1. The matters in CCZ-P4, CCZ-P5, CCZ-P6, CCZ-P7, CCZ-P8, CCZ-P9, CCZ-P10, CCZ-P14 and CCZ-P12 and CCZ-P13; 2. The extent and effect of non-compliance with CCZ-S1, CCZ-S2, CCZ-S3, CCZ-S4, CCZ-S5, CCZ-S6, CCZ-S7, CCZ-S8, CCZ-S9, CCZ-S10, CCZ-S11, CCZ-S12 and CCZ-S13, and CCZ-S13, CCZ-S15 and CCZ-S16; and 3. Construction impacts on the transport network; and 4. The Centres and Mixed-Use Design Guide, including guideline G107 – City Outcomes Contribution for any building that exceeds the maximum height requirement and either comprises 50 or more residential units or is a non-residential building; and 5. The Residential Design Guide. <p>Notification status:</p> <p><u>An application for resource consent made in respect of rule CCZ-R23.2.a that complies with all of the identified standards in CCZ-R23.2.a.2 is precluded from being either publicly or limited notified.</u></p> <p>An application for resource consent made in respect of rule CCZ-R2349.2.a which results in non-compliance with CCZ-S5, CCZ-S9, and CCZ-S10, CCZ-S11, CCZ-S12 and CCZ-S13 is precluded from being either publicly or limited notified.</p> <p>An application for resource consent made in respect of rule CCZ-R2349.2.a which results in non-compliance with CCZ-S1, CCZ-S2, CCZ-S3, CCZ-S4, CCZ-S6, CCZ-S7, and CCZ-S8, CCZ-S11, CCZ-S12, CCZ-S13, CCZ-S15 and CCZ-S16 is precluded from being publicly notified.</p>
	<p><u>3. Activity status: Restricted Discretionary</u></p> <p><u>Where:</u></p> <p>a. <u>In addition to the requirements in CCZ-R23.2, any addition to a building or structure where the relevant City Outcome Contribution Height Threshold set out in CCZ-S1 is exceeded.</u></p> <p><u>Matters of discretion are:</u></p> <ol style="list-style-type: none"> 1. <u>The matters in CCZ-P11; and</u> 2. <u>The application and implementation of the City Outcome Contribution set out in Appendix 16.</u> <p><u>Notification status: An application for resource consent made in respect of rule CCZ- R23.3 is precluded from being either publicly or limited notified, except where the application does not satisfy the outcome threshold test in CCZ-P11 City Outcomes Contribution.</u></p>
CCZ-R 2420	Construction of buildings and structures
<p>1. Activity status: Permitted</p>	

Where:

- a. It involves the construction of any new building or structure that:
 - i. Will have a gross floor area of 100m² or less; and
 - ii. Will result in a building coverage of no more than 20 percent; and
- b. Compliance with CCZ-S1, CCZ-S2, CCZ-S3, CCZ-S4, CCZ-S5, CCZ-S6, CCZ-S7, CCZ-S8, CCZ-S9, CCZ-S10, CCZ-S11, CCZ-S12, ~~and CCZ-S13~~, CCZ-S14, CCZ-S15 and CCZ-S16 is achieved.

2. Activity status: **Restricted Discretionary**

Where:

- a. Compliance with any of the requirements of CCZ-R~~2420~~.1, excluding CCZ-S1 and CCZ-S4, cannot be achieved.

Matters of discretion are:

1. The matters in CCZ-P4, CCZ-P5, CCZ-P6, CCZ-P7, CCZ-P8, CCZ-P9, CCZ-P10, ~~CCZ-P14 and CCZ-P12~~ and CCZ-P13;
2. The extent and effect of non-compliance with ~~CCZ-S1~~, CCZ-S2, CCZ-S3, CCZ-S5, CCZ-S6, CCZ-S7, CCZ-S8, CCZ-S9, CCZ-S10, CCZ-S11, CCZ-S12, ~~and CCZ-S13~~, CCZ-S14, CCZ-S15 and CCZ-S16;
- ~~3. The Centres and Mixed-Use Design Guide, including guideline G107 – City Outcomes Contribution for any building that exceeds the maximum height requirement and either comprises 50 or more residential units or is a non-residential building;~~
- ~~4. The Residential Design Guide;~~
4. The extent and effect of any identifiable site constraints;
5. The impacts of related construction activities on the transport network; and
6. The availability and connection to existing or planned three waters infrastructure.

Notification status:

An application for resource consent made in respect of rule CCZ-R24.2.a which complies with all of the identified standards in CCZ-R24.2.2 is precluded from being either publicly or limited notified.

An application for resource consent made in respect of rule R~~2420~~.2.a which results in non-compliance with CCZ-S5, CCZ-S9, and CCZ-S10, ~~CCZ-S11, CCZ-S12 and CCZ-S13~~ is precluded from being either publicly or limited notified.

An application for resource consent made in respect of rule R~~2420~~.2.a which results from non-compliance with ~~CCZ-S1~~, CCZ-S2, CCZ-S3, CCZ-S6, CCZ-S7, ~~and CCZ-S8~~, CCZ-S11, CCZ-S12, CCZ-S13, CCZ-S15 and CCZ-S16 is precluded from being publicly notified.

3. Activity status: **Restricted Discretionary**

Where:

- a. In addition to the requirements in CCZ-R24.2, the relevant City Outcome Contribution Height Threshold set out in CCZ-S1 is exceeded.

Matters of discretion are:

- ~~3-1. The matters in CCZ-P11; and~~
- ~~4-2. The application and implementation of the City Outcome Contribution set out in Appendix 16.~~

Notification status:

P1 Sch1

	<p>An application for resource consent made in respect of rule CCZ- R24.3 is precluded from being either publicly or limited notified, <u>except where the application does not satisfy the outcome threshold test in CCZ-P11 City Outcomes Contribution.</u></p>
	<p>4.3. Activity status: Discretionary</p> <p>Where:</p> <p>a. Compliance with the requirements of CCZ-S4 cannot be achieved.</p> <p>Notification status:</p> <p>An application for resource consent made in respect of rule CCZ- R2420.43 <u>which results in non-compliance with CCZ-S4</u> is precluded from being either publicly or limited notified, <u>except where the application does not satisfy the outcome threshold test in CCZ-P11 City Outcomes Contribution.</u></p>

CCZ-R2524	Conversion of buildings, or parts of buildings, for residential activities
-----------------------------	---

P1 Sch1

	<p>1. Activity status: Restricted Discretionary</p> <p>Matters of discretion are:</p> <ol style="list-style-type: none"> The matters in CCZ-P1, CCZ-P4, <u>and</u> CCZ-P10 <u>and</u> CCZ-P13; The extent of compliance with standards CCZ-S9, CCZ-S10 and CCZ-S13 and satisfaction of associated assessment criteria; <u>and</u> The relevant guidance contained within the Residential Design Guide; and 4.3. The availability and connection to existing or planned three waters infrastructure. <p>Notification status: An application for resource consent made in respect of rule CCZ-R2524.1 is precluded from being either publicly or limited notified.</p>
--	--

CCZ-R2622	Outdoor storage areas
-----------------------------	------------------------------

	<p>1. Activity status: Permitted</p> <p>Where:</p> <ol style="list-style-type: none"> The storage area is screened by either a fence or landscaping of 1.8m in height from any adjoining road or site. <u>Screening does not obscure emergency or safety signage or obstruct access to emergency panels, hydrants, shut-off valves, or other emergency response facilities.</u>
	<p>2. Activity status: Restricted Discretionary</p> <p>Where:</p> <p>a. Compliance with the requirements of CCZ-R2622.1 cannot be achieved</p> <p>Matters of discretion are:</p> <ol style="list-style-type: none"> The matters in CCZ-P7 and CCZ-P10; The extent to which any lesser screening is necessary to provide for functional or

- operational requirements of the activities on the site, or for people’s health and safety; and
- 3. The extent to which outdoor storage is visible to surrounding areas, including any associated effects on amenity values where visible from residential or open space areas.

Notification status: An application for resource consent made in respect of rule CCZ-R~~2622~~ is precluded from being publicly and limited notified.

Rules: Building and structures activities in the Te Ngākau Civic Square Precinct (CCZ-PREC01)

ISPP

CCZ-PREC01-R~~107~~

Construction of buildings and structures, additions and alterations to buildings and structures

1. Activity status: **Restricted Discretionary**

Matters of discretion are:

- 1. The matters in CCZ-PREC01-P2, CCZ-PREC01-P3 and CCZ-PREC01-P4;
- 2. The extent and effect of non-compliance with CCZ-S1, CCZ-S3, CCZ-S5, CCZ-S6, CCZ-S7, CCZ-S8, CCZ-S9, CCZ-S10, CCZ-S11, CCZ-S12 and CCZ-S13;
- ~~3. The Centres and Mixed Use Design Guide;~~
- ~~4. The Residential Design Guide;~~
- ~~5. 3.~~ The outcomes of any consultation undertaken with mana whenua;
- ~~6. 4.~~ The extent and effect of any identifiable site constraints;
- ~~7. 5.~~ The extent to which the proposed building or addition/alteration respects the form, scale and style of historic heritage buildings located within the precinct;
- ~~8. 6.~~ The extent to which the new building or addition/alteration to a building has an adverse impact on the micro-climate of surrounding public space, including any impacts on sunlight access and wind protection; and
- ~~9. 7.~~ The design, scale and configuration of the proposed building/structure or building additions/ alterations, including:
 - a. The scale of development anticipated within the precinct and in the vicinity of the site;
 - b. Their visual and architectural quality based on such factors as form, scale, design, portion and detailing of the building/structure or building additions/alterations; and
 - c. The safe movement of people to, from and within the site, precinct and surrounding transport and street network.

Notification status: An application for resource consent made in respect of rule CCZ-PREC01-R~~107~~.1 for any additions and alterations to a building or structure, is precluded from being either ~~must be~~ publicly or limited notified.

2. Activity status: **Restricted Discretionary**

Where:

- a. In addition to the requirements in CCZ-PREC01-R10, tThe relevant City Outcome Contribution Height Threshold set out in CCZ-PREC01-S1 is exceeded.

Matters of discretion are:

- 1. The matters in CCZ-P11; and
- 2. The application and implementation of the City Outcome Contribution set out in Appendix 16.

Notification status: An application for resource consent made in respect of rule CCZ-PREC01-R10.2 is precluded from being either publicly or limited notified, except where the application does not satisfy the outcome threshold test in CCZ-P11 City Outcomes Contribution.

Standards

City Centre Zone

ISPP

CCZ-S1	<u>Maximum height City Outcomes Contribution Height Threshold</u>
---------------	--

<p>1. The following maximum height limits <u>The following City Outcomes Contribution Height Thresholds must be complied with</u> (measured above ground level unless otherwise specified) <u>apply to any new building or addition to an existing building:</u></p>	<p>Assessment criteria where the standard is infringed:</p> <ol style="list-style-type: none"> 1. Streetscape and visual amenity effects; 2. Dominance and privacy effects on adjoining sites; and 3. The extent to which taller buildings would substantially contribute to increasing residential accommodation in the city. 																						
<table border="1" style="width: 100%;"> <thead> <tr> <th style="width: 70%;">Location</th> <th style="width: 30%;">Limit Height threshold</th> </tr> </thead> <tbody> <tr> <td>a. Height Control Area 1 – Thorndon Quay</td> <td>35.4m</td> </tr> <tr> <td>b. Height Control Area 2 – Waterloo Quay section</td> <td>50m</td> </tr> <tr> <td>c. Height Control Area 3 – Bulk of Thorndon</td> <td>27m</td> </tr> <tr> <td>d. Height Control Area 4 – Mid and Upper Molesworth Street</td> <td>43.8m</td> </tr> <tr> <td>e. Height Control Area 5 - CBD East</td> <td>48.5m-93m</td> </tr> <tr> <td>f. Height Control Area 6 - CBD West</td> <td>75m-95m (MSL) Mean Sea Level as defined by the New Zealand Vertical Datum 2016 (NZVD2016)</td> </tr> <tr> <td>g. Height Control Area 7– Southern edge of CBD</td> <td>43.8m</td> </tr> <tr> <td>h. Height Control Area 8 –Te Aro</td> <td>42.5m</td> </tr> <tr> <td>i. Height Control Area 9 - South-East, South-West Zone Edge</td> <td>28.5m</td> </tr> <tr> <td>j. Height Control Area 10 - Adelaide Road</td> <td>42.5m</td> </tr> </tbody> </table>	Location	Limit Height threshold	a. Height Control Area 1 – Thorndon Quay	35.4m	b. Height Control Area 2 – Waterloo Quay section	50m	c. Height Control Area 3 – Bulk of Thorndon	27m	d. Height Control Area 4 – Mid and Upper Molesworth Street	43.8m	e. Height Control Area 5 - CBD East	48.5m-93m	f. Height Control Area 6 - CBD West	75m-95m (MSL) Mean Sea Level as defined by the New Zealand Vertical Datum 2016 (NZVD2016)	g. Height Control Area 7– Southern edge of CBD	43.8m	h. Height Control Area 8 –Te Aro	42.5m	i. Height Control Area 9 - South-East, South-West Zone Edge	28.5m	j. Height Control Area 10 - Adelaide Road	42.5m	
Location	Limit Height threshold																						
a. Height Control Area 1 – Thorndon Quay	35.4m																						
b. Height Control Area 2 – Waterloo Quay section	50m																						
c. Height Control Area 3 – Bulk of Thorndon	27m																						
d. Height Control Area 4 – Mid and Upper Molesworth Street	43.8m																						
e. Height Control Area 5 - CBD East	48.5m-93m																						
f. Height Control Area 6 - CBD West	75m-95m (MSL) Mean Sea Level as defined by the New Zealand Vertical Datum 2016 (NZVD2016)																						
g. Height Control Area 7– Southern edge of CBD	43.8m																						
h. Height Control Area 8 –Te Aro	42.5m																						
i. Height Control Area 9 - South-East, South-West Zone Edge	28.5m																						
j. Height Control Area 10 - Adelaide Road	42.5m																						
<p>2. Fences and standalone walls must not exceed a maximum height of 1.8 metres (measured above ground level).</p>																							

<p>- This standard does not apply to:</p> <ul style="list-style-type: none"> a. Solar panel and heating components attached to a building provided these do not exceed the <u>height City Outcomes Contribution Height Threshold</u> by more than 500mm; b. Satellite dishes, antennas, aerials, chimneys, flues, architectural or decorative features (e.g. finials, spires) provided that none of these exceed 1m in diameter and do not exceed the <u>height City Outcomes Contribution Height Threshold</u> by more than 1m; and c. Lift overruns provided these do not exceed the <u>height City Outcomes Contribution Height Threshold</u> by more than 4m; <p><u>b-d. Fences and standalone walls; and</u> <u>e. Circumstances where up to 50% of a building's roof in elevation exceeds the City Outcomes Contribution Height Threshold where the entire roof slopes 15° or more.</u></p>	
--	--

ISPP

<p>CCZ-S2</p>	<p>Old St Paul's Church – Adjoining site specific building height</p>
---------------	---

1. Buildings and structures on sites bounded by Mulgrave Street, Pipitea Street, Moore Street and Thorndon Quay (refer to Diagram 17 – CCZ: Old St Paul’s Church – Adjoining Site Specific Building Height below):
 - a. Maximum height:
 - i. Southern, western and eastern site boundaries: 10m above and parallel to each of the Old St Paul’s site boundaries, rising at an angle to the horizontal of 1.5 vertical to 1 horizontal outwards in a direction perpendicular to the boundary.
 - ii. Northern site boundary: 10m above and parallel to the Old St Paul’s site boundary, rising at an angle to the horizontal of 1.5 vertical to 1 horizontal extending outwards in a north (i.e. perpendicular to the boundary) and north east direction (i.e. 45 degrees off perpendicular).
 - iii. Building line restriction area: No building or part thereof is permitted to be erected above the existing ground level between the building line restriction and Mulgrave Street as shown in Diagram 17 below.

Assessment criteria where the standard is infringed:

1. Dominance and shading effects on Old St Paul’s Church and associated setting.

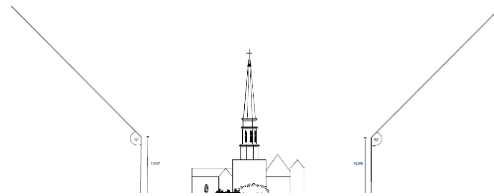

- KEY**
- Old St Paul's Church Site
 - Building Line
 - Recession Plane Section Cut
 - Building Line Restriction

Note: This standard prevails over the general height requirements specified in CCZ-S1.

ISPP

	CCZ-S3	Character precincts and Residentially Zoned heritage areas – Adjoining site specific building and structure height
	<p>1. Identified character precincts and Residentially Zoned heritage areas:</p> <p style="margin-left: 20px;">a. For any site adjoining a site identified within a Character Precinct or a Residentially Zoned Heritage Area: no part of any building, accessory building or structure may project beyond a line of 60° measured from a height of 8m above ground level from all side and rear boundaries that adjoin that precinct.</p> <p>This standard does not apply to:</p> <p style="margin-left: 20px;">a. Fences or standalone walls no greater than 1.8m in height;</p> <p style="margin-left: 20px;">b. Solar panel and heating components attached to a building provided these do not exceed the height by more than 500mm;</p> <p style="margin-left: 20px;">c. Satellite dishes, antennas, aerials, chimneys, flues, architectural or decorative features (e.g. finials, spires) provided that none of these exceed 1m in diameter and do not exceed the height by more than 1m; and</p> <p style="margin-left: 20px;">d. Lift overruns provided these do not exceed the height by more than 4m.</p> <p>Note: this standard prevails over the general height requirements specified in CCZ-S1.</p>	<p>Assessment criteria where the standard is infringed:</p> <p style="margin-left: 20px;">1. Dominance and shading effects on adjoining sites.</p>

ISPP

	CCZ-S4	Minimum building height
	<p>1. A minimum height of 22m is required for new buildings or structures.</p> <p>This standard does not apply to:</p> <p style="margin-left: 20px;">1. Any site adjoining a site located within a character precinct or Residentially Zoned Heritage Area and thus subject to CCZ-S3; and</p> <p style="margin-left: 20px;">2. Any site within the Te Ngākau Civic Square Precinct.</p>	<p>Assessment criteria where the standard is infringed:</p> <p style="margin-left: 20px;">1. The extent to which a reduced height is necessary to provide for the functional needs or operational needs of a proposed activity; and</p> <p style="margin-left: 20px;">2. Whether topographical or other site</p> <p style="margin-left: 20px;">3. constraints make compliance with the standard impracticable or unnecessary.</p>

ISPP

	CCZ-S5	Minimum ground floor height
	<p>1. The minimum ground floor height to <u>the</u> underside of <u>a</u> structural slab or equivalent shall be 4m.</p>	<p>Assessment criteria where the standard is infringed:</p> <p style="margin-left: 20px;">1. The extent to which a reduced height:</p> <p style="margin-left: 40px;">a. Will compromise or preclude future use or adaptation of the</p>

	<p>ground floor for non-residential activities;</p> <p>b. Is necessary to provide for functional needs or operational needs of a proposed activity; and</p> <p>2. Whether topographical or other Site constraints make compliance with the standard impracticable or unnecessary.</p>
--	---

ISPP

CCZ-S6	Minimum sunlight access – public space
---------------	---

<p>1. All buildings or structures within the City Centre Zone must be designed and located to maintain sunlight access to any area mapped with the "Minimum Sunlight Access - Public Space Requirements", during the time periods specified in Table 1 of Appendix 9;</p> <p>2. For areas in Appendix 9 with a specified time period:</p> <ul style="list-style-type: none"> a. 11:30am-1:30pm; b. 12:00pm-2pm; or c. 1:30pm-3:00pm; and <p>Sunlight access must be maintained in the entire area during this period.</p> <p>3. For areas in Appendix 9 with a specified time period:</p> <ul style="list-style-type: none"> a. 10:00am-3:00pm; or b. 10:00am-4:00pm; and <p>Sunlight access must be maintained in a minimum of 70% of the area during this period.</p> <p><u>4.</u> This standard does not apply to:</p> <ul style="list-style-type: none"> a. Any temporary structure erected and dismantled in less than 30 days; and b. Any public amenity facility erected within an identified public space. 	<p>Assessment criteria where the standard is infringed:</p> <p>1. The extent of increased shadowing and any associated adverse amenity effects on the open space.</p>
---	---

ISPP

CCZ-S7	Verandahs
---------------	------------------

<p>1. Verandahs must be provided on building elevations on identified street frontages;</p> <p>2. Any verandah must:</p> <ul style="list-style-type: none"> a. Extend the full width of the building elevation; b. Connect with any existing adjoining verandah; c. Have a minimum clearance of 2.5m directly above the footpath or formed ground surface; 	<p>Assessment criteria where the standard is infringed:</p> <p>1. The extent to which any non-compliance:</p> <ul style="list-style-type: none"> a. Will adversely affect the comfort and convenience of pedestrians; b. Will result in further street trees being added to public space as part the
---	--

<p>d. Not exceed a maximum height of 4m measured between the base of the verandah fascia and the footpath or formed ground surface directly below;</p> <p>e. Be setback a minimum of 450mm from any point along the kerbing extending back to the site boundary; and</p> <p>f. Not exceed a maximum width of 3m from the front of the building.</p> <p>This standard does not apply to:</p> <p>a. Any scheduled building identified in SCHED1 - Heritage Buildings. However, if for any reason these buildings received resource consent approval to be demolished, then a verandah would be required for any replacement buildings on these sites; and</p> <p>b. Any building where compliance with the standard results in an encroachment into the dripline of an existing street-tree; and-</p> <p>c. <u>Service stations.</u></p>	<p>development; and</p> <p>2. The continuity of verandah coverage along the identified street, informal access route or public space.</p>
---	---

ISPP

CCZ-S8	Active frontage control
---------------	--------------------------------

<p>1. Any new building or addition to an existing building adjoining facing an identified street with an active frontage control must:</p> <p>a. Be built up to the street edge at ground floor level along at least 90% on all street boundaries and along the of the full width of the site that borders the street(s) bordering any street boundary;</p> <p>b. Provide a minimum of 60% of continuous display windows or transparent glazing along the width of the ground floor building frontage; and</p> <p>c. Locate the principal public entrance on the front boundary.</p> <p><u>This standard does not apply to</u>Except that:</p> <p>a. <u>Any vehicle and pedestrian access to a site situated on a street subject to an active frontage control;</u></p> <p>a. b. This does not apply to aAny heritage building identified in SCHED1-heritage buildings or service stations; and</p> <p>3. Any ground level addition to, or alteration of, a building or structure facing a public space must not result in a featureless façade that:</p> <p>a. Is more than 4 metres wide;</p> <p>b. Extends from a height of 1m above ground level to a maximum height of 2.5m; and</p> <p>c. Any roller shutter doors, security grilles, screens or similar structures fitted to the facade of any building must be at least 50% visually transparent.</p>	<p>Assessment criteria where the standard is infringed:</p> <p>1. The extent to which:</p> <p>a. Any non-compliance is required for on-site functional needs or operational needs;</p> <p>b. The building frontage is designed and located to create a strong visual alignment with adjoining buildings or otherwise enhances the streetscape; and</p> <p>c. An acceptable level of passive surveillance is maintained between the interior of the building and the street.</p>
---	--

ISPP

CCZ-S9	Minimum residential – unit size	
1. Residential units, including any dual key unit, must meet the following minimum sizes:		Assessment criteria where the standard is infringed: 1. The extent to which: a. The design of the proposed unit provides a good standard of amenity; and b. Other on-site factors compensate for a reduction in unit size.
Residential unit type	Minimum net floor area	
a. Studio unit	35m ²	
b. 1 bedroom unit	40m ²	
c. 2+ bedroom unit	55m ²	

ISPP

CCZ-S10	Residential – outdoor living space		
1. Each residential unit, including any dual key unit, must be provided with either a private outdoor living space or access to a communal outdoor living space; 2. Where private outdoor living space is provided it must be: a. For the exclusive use of residents; b. Directly accessible from a habitable room; c. A single contiguous space; and d. Of the minimum area and dimension specified in the table below; 3. Where communal outdoor living space is provided it does not need to be a single continuous space but it must be: a. Accessible from the residential units it serves; b. Of the minimum area and dimension specified in the table below; and c. Free of buildings, parking spaces, and servicing and manoeuvring areas.		Assessment criteria where the standard is infringed: 1. The extent to which: a. Any proposed outdoor living space provides a good standard of amenity relative to the number of occupants the space is designed for; b. Other on-site factors compensate for a reduction in the size or dimension of the outdoor living space; and c. The availability of public open space in proximity to the site.	
Living space type	Minimum area		Minimum dimension
a. Private			
i. Studio unit and 1- bedroom unit	5m ²		1.8m
ii. 2+ bedroom unit	8m ²		1.8m
b. Communal			
i. For every 5 <u>4-15</u> units	1064m² per unit		8m
ii. <u>For each additional unit above 15 units</u>	<u>2m²</u>		=

Note: Communal outdoor living space is calculated on the basis of the number of units without exclusive access to private outdoor living space.

ISPP

CCZ-S11

Minimum building separation distance for residential activities

1. Any new building or addition to an existing building used for residential activities must provide a 8m separation distance between buildings located on the same site, as shown in Diagram 18 and Diagram X below.

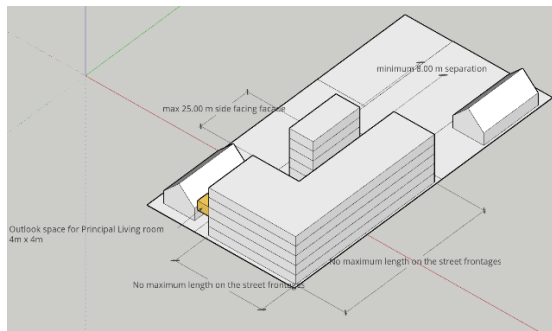
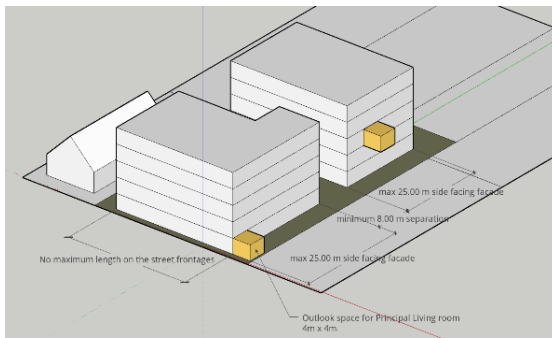
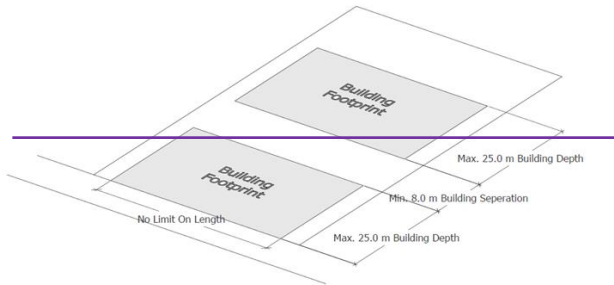

Assessment criteria where the standard is infringed:

1. The extent to which a reduced setback will increase dominance and shadowing related effects on residential units within the development site; and
2. Dominance and privacy effects on adjoining sites.

ISPP

CCZ-S12

Maximum building depth for residential activities

- Any new building, part of a new building, or additions to an existing building, constructed for residential activities on any site aside from a rear site, must not result in the continuous depth length of any external side wall façade, facing a neighbouring site, being greater than 25m, as shown in Diagram 19 and Diagram X below.

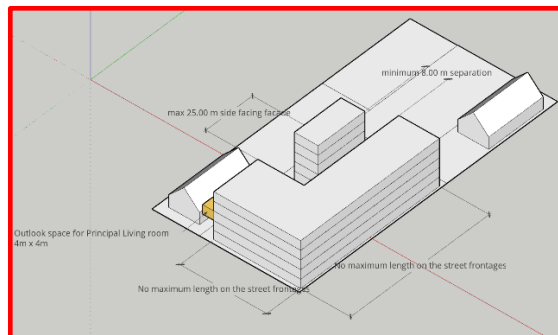
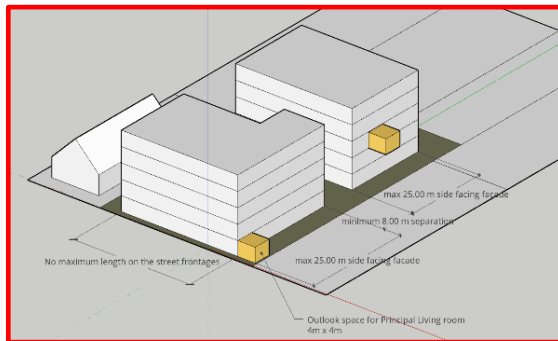
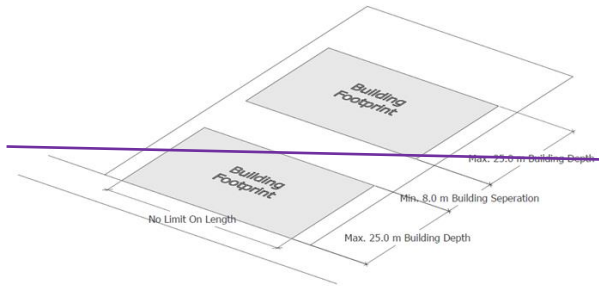

Assessment criteria where the standard is infringed:

- The extent to which the design mitigates the effect of a long featureless building façade; and
- Dominance and privacy effects on adjoining sites.

ISPP

CCZ-S13

Outlook space

- An outlook space must be provided for each residential unit as specified in this standard;
- All principal living rooms must have an outlook space of a minimum dimension of 4m in depth and 4m in width as shown in Diagram X and Diagram X below.
- All habitable rooms must have an outlook space of a minimum dimension of 1m in depth

Assessment criteria where the standard is infringed:

- The extent to which:
 - Acceptable levels of natural light are provided to habitable rooms;
 - The design of the proposed unit provides a healthy living environment; and
 - The extent of dominance and privacy related effects on

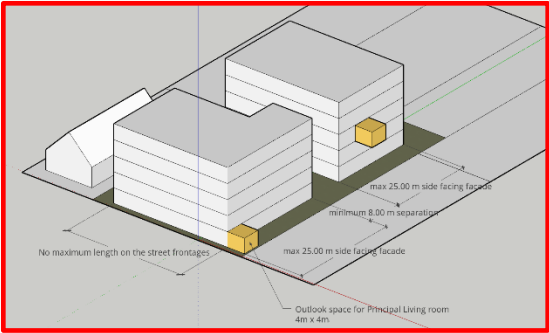
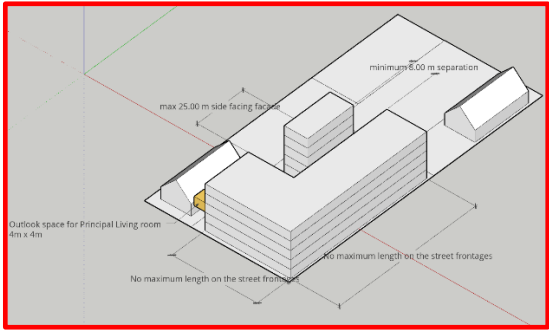
<p>and 1m in width <u>as shown in Diagram X and Diagram X below</u>;</p> <p><u>3-4</u>. The width of the outlook space is measured from the centre point of the largest window on the <u>building</u> face to which it applies;</p> <p><u>4-5</u>. Outlook spaces may be over driveways and footpaths within the <u>site</u> or over a public street or other public open space;</p> <p><u>5-6</u>. Outlook spaces may overlap where they are on the same wall plane in the case of a multi-storey <u>building</u>;</p> <p><u>6-7</u>. Outlook spaces may be under or over a balcony;</p> <p><u>7-8</u>. Outlook spaces required from different rooms within the same <u>building</u> may overlap; and</p> <p><u>8-9</u>. Outlook spaces must:</p> <ol style="list-style-type: none"> be clear and unobstructed by <u>buildings</u>; and not extend over an outlook space or <u>outdoor living space</u> required by another dwelling.  	<p>adjoining sites.</p>
--	-------------------------

ISPP

CCZ-S14

Fences and standalone walls

<p>1. <u>Fences and standalone walls must not exceed a maximum height of 1.8 metres (measured above ground level).</u></p>	<p><u>Assessment criteria where the standard is infringed:</u></p> <ol style="list-style-type: none"> <u>Streetscape and visual amenity effects; and</u> <u>Dominance and privacy effects on adjoining sites.</u>
--	---

ISPP

	<u>CCZ-S15</u>	<u>Boundary setback from a rail corridor</u>
	<p>1. <u>Buildings or structures must not be located within 1.5m of the boundary of a designated rail corridor.</u></p>	<p><u>Assessment criteria where the standard is infringed:</u></p> <p>1. <u>The extent to which the location and design of the building relates to the ability to safely use, access and maintain buildings without requiring access on, above or over the rail corridor.</u></p>

ISPP

	<u>CCZ-S16</u>	<u>Sites adjoining residential zones</u>
	<p>1. <u>For any site adjoining a Residentially Zoned site:</u></p> <p style="margin-left: 20px;">a. <u>no part of any building, accessory building or structure may project beyond a line of 60° measured from a height of 19m above ground level from all side and rear boundaries that adjoin the Residentially Zoned site.</u></p> <p><u>This standard does not apply to:</u></p> <p style="margin-left: 20px;">a. <u>Fences or standalone walls no greater than 1.8m in height;</u></p> <p style="margin-left: 20px;">b. <u>Solar panel and heating components attached to a building provided these do not exceed the height by more than 500mm;</u></p> <p style="margin-left: 20px;">c. <u>Satellite dishes, antennas, aerials, chimneys, flues, architectural or decorative features (e.g. finials, spires) provided that none of these exceed 1m in diameter and do not exceed the height by more than 1m; and</u></p> <p style="margin-left: 20px;">d. <u>Lift overruns provided these do not exceed the height by more than 4m.</u></p> <p><u>Note: this standard prevails over the general height requirements specified in CCZ-S1.</u></p>	<p><u>Assessment criteria where the standard is infringed:</u></p> <p>1. <u>Dominance and shading effects on adjoining sites.</u></p>

Te Ngākau Civic Square Precinct					
ISPP	<table border="1"> <tr> <td style="text-align: center;">CCZ- PREC01-S1</td> <td style="text-align: center;">Maximum height <u>City Outcomes Contribution Threshold</u></td> </tr> </table>	CCZ- PREC01-S1	Maximum height <u>City Outcomes Contribution Threshold</u>		
CCZ- PREC01-S1	Maximum height <u>City Outcomes Contribution Threshold</u>				
<p>1. The following maximum height limit <u>City Outcomes Contribution Height Thresholds above ground level must be complied with (measured above ground level unless otherwise specified) apply to any new building or addition to an existing building:</u></p> <table border="1"> <thead> <tr> <th style="text-align: left;">Location</th> <th style="text-align: left;">Limit <u>Height Threshold</u></th> </tr> </thead> <tbody> <tr> <td>a. Entire Precinct</td> <td>40m</td> </tr> </tbody> </table> <p>This standard does not apply to:</p> <ul style="list-style-type: none"> a. Solar panel and heating components attached to a building provided these do not exceed the height <u>City Outcome Contribution Threshold</u> by more than 500mm; b. Satellite dishes, antennas, aerials, chimneys, flues, architectural or decorative features (e.g. finials, spires) provided that none of these exceed 1m in diameter and do not exceed the height <u>City Outcomes Contribution Threshold</u> by more than 1m; and c. Lift overruns provided these do not exceed the height <u>City Outcomes Contribution Height Threshold</u> by more than 4m-; d. Fences and standalone walls; and e. Circumstances where up to 50% of a building's roof in elevation exceeds the <u>City Outcomes Contribution Height Threshold</u> where the entire roof slopes 15° or more. 		Location	Limit <u>Height Threshold</u>	a. Entire Precinct	40m
Location	Limit <u>Height Threshold</u>				
a. Entire Precinct	40m				
<p>Assessment criteria where the standard is infringed:</p> <ol style="list-style-type: none"> 1. Dominance and shading effects within the Precinct and on adjoining sites; and 2. Streetscape and visual amenity Effects; and 3. <u>The extent to which taller buildings would substantially contribute to increasing residential accommodation in the city.</u> 					

Methods

<u>CCZ-M1</u>	<u>Urban Design Panel</u>
---------------	---------------------------

Subject to obtaining relevant approvals and supporting funding Council will seek to establish and facilitate an independent, non-statutory Urban Design Panel to inform urban design assessments of relevant policies and matters of discretion that apply to significant resource consent applications as required.

Reader note: Where I recommend changes in response to submissions, these are shown as:

- Text recommended to be added to the PDP is underlined.
- Text recommended to be deleted from the PDP is ~~struck through~~.



Figure 1: New Waterfront Public Open Space specific control north of Bell Gully building

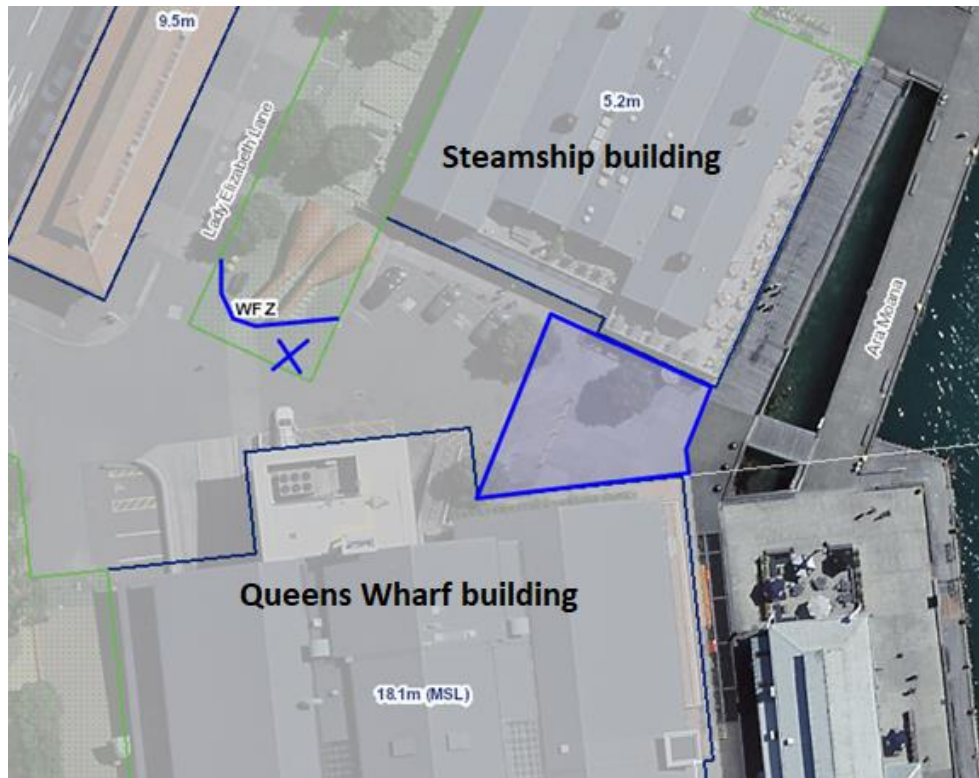

Figure 2: Amended delineation and new area of Waterfront Public Open Space specific control around the Steamship building. X = Area to remove the Public Open Space.

Recommend aligning Plan map layers with sea walls in the Waterfront Zone

Maps 1-3 show how the Plan's spatial layers' seaward boundaries within the Waterfront Zone are better aligned with the survey map of the precast concrete and rock revetment walls along the red line that indicates mean high water springs.



Location of Waterfront Sea Walls - Map 1

This maps shows the location of the sea walls along the Wellington Waterfront. It includes the Proposed District Plan Zones and Specific Controls, and building footprints.

Basemap credits: Esri Community Maps Contributors, LINZ, Stats NZ, Esri, HERE, Garmin, Foursquare, METI/ NASA, USGS, LINZ

Date: 31/05/2023
 Contact: District.Plan@wcc.govt.nz

Absolutely Positively
Wellington City Council
 Me Heke Ki Pōneke



Location of Waterfront Sea Walls - Map 2

This maps shows the location of the sea walls along the Wellington Waterfront. It includes the Proposed District Plan Zones and Specific Controls, and building footprints.

Basemap credits: Esri Community Maps Contributors, LINZ, Stats NZ, Esri, HERE, Garmin, Foursquare, METV, NASA, USGS, LINZ

Date: 31/05/2023
 Contact: District.Plan@wcc.govt.nz

**Absolutely Positively
 Wellington City Council**
 Me Heke Ki Pōneke



Location of Waterfront Sea Walls - Map 3

This map shows the location of the sea walls along the Wellington Waterfront. It includes the Proposed District Plan Zones and Specific Controls, and building footprints.

Basemap credits: Esri Community Maps Contributors, LINZ, Stats NZ, Esri, HERE, Garmin, Foursquare, METI/NASA, USGS, LINZ

Date: 31/05/2023
Contact: District.Plan@wcc.govt.nz

Absolutely Positively
Wellington City Council
Me Heke Ki Pōneke

Parts of this chapter have been notified using either a Part One Schedule 1 process (**P1 Sch1**), or as part of an Intensification Planning Instrument using the Intensification Streamlined Planning Process (**ISPP**). Please see notations.

He Rohe Tāhuna

Waterfront Zone

WFZ	Waterfront Zone
------------	------------------------

P1 Sch1

Introduction

The Waterfront Zone provides an interface between the city centre and Te Whanganui a Tara. It contains one of the city's primary promenades along with two major parks: Frank Kitts Park and Waitangi Park. It caters to a variety of cultural, recreation and entertainment activities and includes buildings such as Te Papa, Te Wharewaka o Pōneke and the Events Centre along with residential apartment living.

The land now covered by the Waterfront Zone was created through reclamation, structures and encroachments into the harbour that are seaward of the original natural shoreline from the late 1800s to 1970. Its original purpose was to facilitate travel, trade, and general industry and commerce. The Zone has a number of remaining heritage buildings and other structures from this era that influence its character today.

Development since the 1980s on the land covered by the Waterfront Zone has transformed the area into a space for recreation, events, arts and culture, business, residences, and active transport including walking and cycling. This evolution of the waterfront is in line with the vision of the Wellington Waterfront Framework (2001), which is still relevant and important today:

Wellington's Waterfront is a special place that welcomes all people to live, work and play in the beautiful and inspiring spaces and architecture that connects our city to the sea and protect our heritage for future generations.

The Council uses the Wellington Waterfront Framework to help manage the waterfront in its role as property owner and manager of the land and public assets. The Framework has also helped inform the Waterfront Zone content in this District Plan.

Mana whenua, particularly Te Āti Awa, have an important connection with Te Whanganui a Tara and the Whairepo Lagoon. Both Taranaki Whānui and Ngāti Toa's Claims Settlement Acts identify the Wellington Harbour as a statutory area. Wellington City Council must have regard to these statutory acknowledgments. The Natural Resources Plan for the Wellington Region (Schedule C4 Map 6) identifies a coastal site adjoining the Waterfront Zone with significant mana whenua values linked to the historic Te Aro Pā. The Waterfront Zone recognises the landward side of this site as also having particular significance to mana whenua, anchored by Te Wharewaka o Pōneke, through a method enabling greater mana whenua involvement in resource consents and plan changes affecting this area.

Management of the Waterfront area needs to be integrated across mean high water springs and actively engage mana whenua and other agencies with management responsibilities.

When constructing new and redeveloped buildings and public spaces, the Waterfront Zone requires public involvement and weighs the public interest very highly as the Zone is predominantly a public area. Applications for significant new development in the Waterfront Zone are publicly notified, [as specified in the relevant rules' notification status.](#)

Eventually, the Waterfront Zone is anticipated to be extended further north to the ramp that connects to the Fran Wilde Walkway (the walkway to the Wellington Regional Stadium). This extension would replace the Inner Harbour Port Precinct. This is currently CentrePort land that was previously partly redeveloped into office buildings and is currently zoned Port Zone. Any Zone extension will be done through a plan change. The plan change process would include a companion master plan to guide the comprehensive redevelopment.

Activities that cross the mean high water springs boundary will be managed by having regard to the Proposed Natural Resources Plan for the Wellington Region and in conjunction with the Greater Wellington Regional Council.

The Waterfront has three areas where specific controls apply. These areas of specific controls are identified in the Planning Maps. They are:

1. Areas of change. These are areas identified for redevelopment into buildings and/or public spaces.
2. Public open spaces. These are public spaces specifically mapped within the Waterfront Zone to be retained for public activities with minimal buildings.
3. Queens Wharf buildings. These areas have specific height standards and external alternation and addition rules.

These three specific controls are mentioned in some Waterfront Zone objectives and policies, and are labelled to the left of the relevant rules for building and structure activities. The label "Entire Zone" to the left of a rule or standard means the rule or standard applies to areas both with and without specific controls, unless otherwise specified.

Other relevant District Plan provisions

There may be a number of provisions that apply to an activity, building, structure or site. Resource consent may therefore be required under rules in this chapter as well as other chapters. Unless specifically stated in a rule, resource consent is required under each relevant rule. The steps to determine the status of an activity are set out in the General Approach chapter.

Objectives

ISPP

WFZ-01

Purpose

Activities and development in the Waterfront Zone contribute to Wellington's identity and sense of place, with public spaces, buildings and other structures that reflect the unique ~~and special components and elements that make up location and~~ character of the waterfront.

ISPP

WFZ-02

Ahi Kā

Taranaki Whānui and Ngāti Toa Rangatira are acknowledged as the mana whenua of Te Whanganui ā Tara (Wellington) and their cultural associations and landowner and development interests are recognised in planning and developing the Waterfront Zone.

ISPP

WFZ-03

Protection of public open spaces

The Waterfront's public open spaces mapped as specific controls are protected and maintained for temporary activities and recreation activity.

ISPP

WFZ-04

Areas of change

		Areas of change are redeveloped over time into high-quality public spaces and buildings.
P1 Sch1	WFZ-O5	<p>Active transport and micro-mobility connectivity Connections to Te Whanganui a Tara, public transport and the City Centre</p> <p>Active transport and micro-mobility connectivity within the Waterfront Zone, and between the edge of Te Whanganui a Tara, public transport and the City Centre <u>are</u>, is maintained or enhanced.</p>
P1 Sch1	WFZ-O6	<p>Vibrant and diverse mix of activities</p> <p>The Waterfront Zone has a diverse and vibrant mix of activities that collectively provide and encourage public interest, use and enjoyment of the Zone during the day and night.</p>
ISPP	WFZ-O7	<p>Managing adverse effects</p> <p>Adverse effects of activities and development in the Waterfront Zone are managed effectively both:</p> <ol style="list-style-type: none"> 1. Within the zone, including on its role, and function <u>and connectivity</u>; and 2. At interfaces with: <ol style="list-style-type: none"> a. Heritage buildings, heritage structures and heritage areas; b. Scheduled sites and areas of significance to Māori; c. Mapped public open space <u>specific controls</u>; d. Identified pedestrian streets; e. Residential zoned areas; f. Open space zoned areas; and g. The coastal marine area.

Policies

P1 Sch1	WFZ-P1	<p>Enabled activities</p> <p>Enable a range and diversity of activities that support the role and function of the Waterfront Zone and enhance the Zone’s vitality, vibrancy and amenity during the day and night, including:</p> <ol style="list-style-type: none"> 1. Commercial activities; 2. Community facilities; 3. Recreation activities; 4. Emergency service facilities; 5. Marae activities; 6. Public transport activities <u>on Waterloo Quay, Customhouse Quay, Jervois Quay, Cable Street, Oriental Parade and in the Post Office Square Heritage Area</u>; 7. Visitor accommodation; and 8. Residential activities above ground floor.
P1 Sch1	WFZ-P2	<p>Managed activities</p> <p>Manage the location and scale of activities which could result in cumulative adverse effects on the vitality, vibrancy and amenity of the Waterfront Zone, including:</p> <ol style="list-style-type: none"> 1. Industrial activities; 2. Construction of apartments and visitor accommodation; 3. New and expanded buildings; 4. New and modified public space; and

		5. <u>Demolition of buildings that results in the creation of unutilised vacant land Public transport activities seaward of Waterloo Quay, Customhouse Quay, Jervois Quay, Cable Street, Oriental Parade and the Post Office Square Heritage Area.</u>
P1 Sch1	WFZ-P3	<p>Incompatible activities</p> <p>Avoid activities that are incompatible with the role and functions of the Waterfront Zone.</p> <p>These incompatible activities include:</p> <ol style="list-style-type: none"> 1. Heavy industrial activities; 2. Demolition of buildings that results in the creation of unutilised vacant land; 3. Ground floor residential activities; 4. Significant buildings in mapped public open space; and 5. Surface-level carparks, other than car parks for people with mobility issues, for service vehicles, and pick-up/drop-off parking
P1 Sch1	WFZ-P4	<p>Access, connections and public space</p> <p>Require that the use, development, and operation of the Waterfront Zone:</p> <ol style="list-style-type: none"> 1. Provides attractive, safe, efficient, and convenient connections to existing and planned transport networks; 2. Promotes and enhances existing and planned pedestrian and cycle access and connections <u>between</u> to the City Centre Zone; 3. Provides well-designed, <u>connected</u> and safe public space and pedestrian, cycle and micro-mobility access; 4. Provides equitable access to and along the edge of the coastal marine area and structures within it; and 5. Provides a safe environment for people that promotes a sense of security and allows informal surveillance.
ISPP	WFZ-P5	<p>Sense of place</p> <p>Require development of public spaces, buildings and other structures to maintain or enhance the sense of place and distinctive form, quality and amenity of the Waterfront Zone including, where relevant:</p> <ol style="list-style-type: none"> 1. A balance of buildings and open space with no more than 35% <u>total</u> building <u>site</u>-coverage over the whole Waterfront Zone to form a sense of openness and transition between the dense city centre environment and the expansiveness of Te Whanganui a Tara; 2. Design relating to the maritime location and activities; 3. Rich Māori and tauīwi/non-Māori history; 4. Sunlight to parks, plazas and other open spaces where people regularly congregate; 5. Visual connections to the City and Te Whanganui a Tara; and 6. Accessibility for people of all ages and mobility levels.
ISPP	WFZ-P6	<p>Development of buildings</p> <p>Require new and altered buildings to be of a high quality, including:</p> <ol style="list-style-type: none"> 1. Building forms and facades, especially those that are visually prominent; 2. Bulk, scale and heights that are complementary to and of a scale appropriate to the existing nearby buildings in the Waterfront Zone; 3. Heights that are consistent with the low-rise nature of buildings in this zone;

		<ol style="list-style-type: none"> 4. Active building frontages and publicly-accessible areas on the ground floors of buildings, except for storage and/or service areas; 5. Storage and/or service areas screened from public view; 6. Sustainable, resilient building design that is adaptable to changes in use over time; 7. Buildings that respond to any identified significant natural hazard risks and climate change effects, including the strengthening and adaptive reuse of existing buildings; and 8. Design that responds positively to identified historic heritage structures, buildings and areas, including those seaward of mean high water springs and identified in the Regional Natural Resources Plan, that are adjacent to the new or altered building; and <p>9. Fulfilling the intent of the Centres and Mixed Use Design Guide.</p>
ISPP	WFZ-P7	<p>Protection of public open space</p> <p>Protect the Waterfront Zone’s mapped public open spaces by avoiding new permanent buildings above-ground on public open space except where they improve the space for public use and enjoyment and do not dominate or cumulatively diminish the public open space.</p>
ISPP	WFZ-P8	<p>Areas of change</p> <p>Enable re-development of Areas of Change from car parking to high quality buildings and/or public spaces.</p>
ISPP	WFZ-P9	<p>Sustainable long term use</p> <p>Encourage new development and redevelopment in the Waterfront Zone to be sustainable, resilient and adaptable to change in use over time, including enabling sufficient flexibility for ground floor space to be used and converted for a range of activities and responding to future coastal hazards.</p>
P1 Sch1	WFZ-P10	<p>Ahi kā</p> <p>Recognise and provide for the cultural associations and development interests of Ngāti Toa Rangatira and Taranaki Whānui ki te Upoko o te Ika in the Waterfront Zone by:</p> <ol style="list-style-type: none"> 1. Managing new development adjoining sites and areas of significance to Māori; and 2. Collaborating on the design and incorporation of Māori cultural elements into public open space within the zone.
Methods		
P1 Sch1	WFZ-M1	<p>Mana whenua involvement in managing the Waterfront Zone</p> <p>For all resource consent applications and private plan change requests in the Waterfront Zone from Te Papa to Frank Kitts Park inclusive, and elsewhere in the Waterfront Zone that affect Te Whanganui a Tara, Wellington City Council will:</p> <ol style="list-style-type: none"> 1. Require the applicant to include a record of engagement with Te Aro Pā Trust and Te Rūnanga o Toa Rangatira with the application for resource consent or request for private plan change; and 2. If a public hearing is required, enable Te Aro Pā Trust and Te Rūnanga o Toa Rangatira to select up to half of the hearing commissioners on the panel to hear submissions and make recommendations or delegated decisions, provided

		these commissioners are certified by the Ministry for the Environment for this purpose.
P1 Sch1	WFZ-M2	<p>Integrated management across mean high water springs</p> <p>Wellington City Council will work with mana whenua, Wellington Regional Council, and other agencies with management responsibilities, on the integrated management of resource management matters across mean high water springs, in particular:</p> <ol style="list-style-type: none"> 1. Activities and development on structures in the coastal marine area that are connected to land; 2. Activities and development, and their effects, that cross the mean high water springs boundary; 3. Communication and information sharing; 4. Improved biodiversity values; and 5. Improved public access to the coast.

Rules: Land use activities

P1 Sch1	WFZ-R1	Commercial activities
---------	---------------	------------------------------

1. Activity status: **Permitted**

P1 Sch1	WFZ-R2	Community facilities
---------	---------------	-----------------------------

1. Activity status: **Permitted**

P1 Sch1	WFZ-R3	Recreation activities
---------	---------------	------------------------------

1. Activity status: **Permitted**

P1 Sch1	WFZ-R4	Emergency service facilities
---------	---------------	-------------------------------------

1. Activity status: **Permitted**

P1 Sch1	WFZ-R5	Marae activities
---------	---------------	-------------------------

1. Activity status: **Permitted**

P1 Sch1	WFZ-R6	Public transport activities
---------	---------------	------------------------------------

1. Activity status: **Permitted**
Where:

a. The activity is located in one or more of:

- i. Waterloo Quay
- ii. Customhouse Quay
- iii. Jervois Quay
- iv. Cable Street
- v. Oriental Parade
- vi. Post Office Square Heritage Area.

2. Activity status: Discretionary
Where:
 -

		a. <u>Compliance with the requirements of WFZ-R6.1 cannot be achieved.</u>
P1 Sch1	WFZ-R7	Visitor accommodation
		1. Activity status: Permitted
P1 Sch1	WFZ-R8	Residential activities
		1. Activity status: Permitted Where: a. The activity is located above ground floor level. Cross-reference – also refer to NOISE-R5 and NOISE-S4 for noise-sensitive controls near the Port Zone.
		2. Activity status: Non-complying Where: a. Compliance with any of the requirements of WFZ-R8.1.a cannot be achieved
P1 Sch1	WFZ-R9	Industrial activities
		1. Activity status: Restricted discretionary Where: a. The activity is not a heavy industrial activity. Matters of discretion are: 1. The extent to which the activity contributes to or detracts from the surrounding activities and public enjoyment; 2. The design of the activity relating to the maritime location and adjacent public open space; and 3. Effects on the safety and amenity of the area, particularly in relation to noise, vehicle movements, dust, odour, fumes and hazardous substances. Notification status: An application for resource consent made in respect of WFZ-R9.1 is precluded from being publicly notified.
		2. Activity status: Non-complying Where: a. Compliance with the requirements of WFZ-R9.1 cannot be achieved Notification status: An application for resource consent made in respect of WFZ-R9.2 must be publicly notified.
P1 Sch1	WFZ-R10	Car parking activities
		1. Activity status: Permitted Where: a. The activity is providing: i. Car parking for people with mobility issues, or ii. Pick-up/drop-off parking of 10 minutes or less, or iii. For service vehicles; or b. The activity is located within a building below ground floor or under public open space; <u>or</u> c. <u>The activity involves the provision of carparks on a road.</u>

P1 Sch1	2. Activity status: Non-complying Where: a. Compliance with the requirements of WFZ-R10.1 cannot be achieved	
	WFZ-R11	All other land use activities
ISPP	Entire zone	2. Activity status: Discretionary Where: a. The activity is not otherwise provided for as a permitted activity, restricted discretionary activity, or a non-complying activity
	Rules: Building and structure activities	
ISPP	WFZ-R12	Maintenance and repair of buildings, structures and public open space
ISPP	Entire Zone	1. Activity status: Permitted
	WFZ-R13	Demolition or removal of buildings and structures
ISPP	Entire Zone	1. Activity status: Permitted Where: a. The demolition or removal of a building: <ul style="list-style-type: none"> i. Is required to avoid an imminent threat to life and/or property; or ii. Enables the creation of public space or for private outdoor living space; or iii. Is required for the purposes of constructing a new building or adding to or altering an existing building that <u>is a permitted activity under WFZ-R14 or WFZ-R15, or that</u> has an approved resource consent or resource consent is being sought concurrently under WFZ-R14 or WFZ-R15; or b. The demolition or removal involves a structure, excluding any building.
	Entire Zone	1. 2. Activity status: Non-complying Where: a. Compliance with the requirements of WFZ-R13.1 cannot be achieved The assessment of the activity must have regard to the Principles and Outcomes in the Wellington City Council Design Guides Introduction [2022]. Notification status: An application for resource consent made in respect of WFZ-R13.1 is precluded from being either publicly or limited notified.
ISPP	WFZ-R14	Alterations or additions to buildings and structures
ISPP	Public Open Space	1. Activity status: Permitted Where: a. The building or structure is: <ul style="list-style-type: none"> i. Waterfront furniture; or

	<ul style="list-style-type: none"> ii. Play equipment; or iii. Sculptures or public art; or iv. Former cargo handling equipment, cranes or similar port-related equipment <p>Or</p> <ul style="list-style-type: none"> b. The alterations or additions result in the building or structure being: <ul style="list-style-type: none"> a. Less than 30 m² in site coverage; and b. Less than 4 metres high; and c. The aggregate area of all buildings in the contiguous public open space does not exceed 200 m² per hectare.
Public Open Space	<p>2. Activity status: Discretionary</p> <p>Where:</p> <ul style="list-style-type: none"> a. Compliance with the requirements of WFZ-R14.1 cannot be achieved <p>The assessment of the activity must have regard to the Principles and Outcomes in the Wellington City Council Design Guides Introduction [2022].</p>
Queens Wharf Buildings	<p>3. Activity status: Controlled</p> <p>Where:</p> <ul style="list-style-type: none"> a. The alterations or additions do not exceed the existing site coverage of the existing building; and b. Compliance with the requirements of WFZ-S1 – WFZ-S6 are achieved. <p>Matters of control are:</p> <ul style="list-style-type: none"> 1. Building design; 2. External appearance of the building; and 3. Siting of the building. <p>Notification status: An application for resource consent made in respect of WFZ-R14.3 is precluded from being either publicly or limited notified.</p>
Queens Wharf Buildings	<p>4. Activity status: Discretionary</p> <p>Where:</p> <ul style="list-style-type: none"> a. Compliance with the requirements of WFZ-R14.3 cannot be achieved <p>The assessment of the activity must have regard to the Principles and Outcomes in the Wellington City Council Design Guides Introduction [2022].</p> <p>Notification status: An application for resource consent made in respect of Rule WFZ-R14.4 must be publicly notified.</p>
Entire Zone, except Public Open Space, Queens Wharf Buildings	<p>5. Activity status: Restricted Discretionary</p> <p>Where:</p> <ul style="list-style-type: none"> a. The alterations or additions do not extend the footprint of the existing building by more than 5% of the footprint at 18 July 2022; and b. Compliance with the requirements of WFZ-S1 – WFZ-S6 are achieved. <p>Matters of discretion are:</p> <ul style="list-style-type: none"> 1. Screening of activities and storage; 2. Dust; 3. Lighting; 4. Design;

	<p>5. External appearance; and</p> <p>6. Height and the placement of building mass; and</p> <p><u>7. The Centres and Mixed Use Design Guide.</u></p> <p>The assessment of the activity must have regard to the Principles and Outcomes in the Wellington City Council Design Guides Introduction [2022].</p>
Entire Zone except Public Open Space, Queens Wharf Buildings	<p>6. Activity status: Discretionary</p> <p>Where:</p> <p>a. Compliance with the requirements of WFZ-R14.5 cannot be achieved</p> <p>The assessment of the activity must have regard to the Principles and Outcomes in the Wellington City Council Design Guides Introduction [2022].</p> <p>Notification status: An application for resource consent made in respect of Rule WFZ-R14.6 <u>where WFZ-R14.5(a) or WFZ-S1 has not been complied with</u> must be publicly notified.</p>
	<p>WFZ-R15 Construction of new buildings and structures</p>
Public Open Space	<p>1. Activity status: Permitted</p> <p>Where:</p> <p>a. The building or structure is:</p> <ul style="list-style-type: none"> i. Outdoor furniture; or ii. Play equipment; or iii. Sculptures or public art; or iv. Former cargo handling equipment, cranes or similar port-related equipment <p>Or</p> <p>b. The new building or structure:</p> <ul style="list-style-type: none"> i. Has a site coverage of less than 30 m²; and ii. Is less than 4 metres high; and c. The aggregate area of all buildings in the contiguous public open space does not exceed 200 m² per hectare.
Public Open Space	<p>2. Activity status: Discretionary</p> <p>Where:</p> <p>a. Compliance with the requirements of WFZ-R15.1.a or b cannot be achieved</p> <p>The assessment of the activity must have regard to the Principles and Outcomes in the Wellington City Council Design Guides Introduction [2022].</p> <p>Notification status: An application for resource consent made in respect of Rule WFZ-R15.2 must be publicly notified.</p>
Public Open Space	<p>3. Activity status: Non-complying</p> <p>Where:</p> <p>a. Compliance with the requirements of WFZ-R15.1.c cannot be achieved</p> <p>The assessment of the activity must have regard to</p>

ISPP

		<p>1. The Principles and Outcomes in the Wellington City Council Design Guides Introduction [2022]; and 2. Standards WFZ-S1, WFZ-S2, and WFZ-S6.</p> <p>Notification status: An application for resource consent made in respect of Rule WFZ-R15.3 must be publicly notified.</p>
	Areas of Change	<p>4. Activity status: Permitted</p> <p>Where:</p> <p>a. The structure is:</p> <ul style="list-style-type: none"> i. Outdoor furniture; or ii. Servicing transport functions; or iii. Sculptures or public art.
	Entire Zone except Public Open Space, Areas of Change	<p>5. Activity status: Permitted</p> <p>Where:</p> <p>a. The building or structure is:</p> <ul style="list-style-type: none"> i. Outdoor furniture; or ii. Play equipment; or iii. Sculptures or public art; or iv. Former cargo handling equipment, cranes or similar port-related equipment <p>Or</p> <p>b. The new building or structure:</p> <ul style="list-style-type: none"> i. Has a site coverage of less than 30 m²; and ii. Is less than 4 metres high.
	Entire Zone except Public Open Space	<p>6. Activity status: Discretionary</p> <p>Where:</p> <p>a. Compliance with the requirements of WFZ-R15.4 or 5 cannot be achieved</p> <p>The assessment of the activity must</p> <ul style="list-style-type: none"> 1. Ensure that the bulk, scale and height of any new buildings achieve WFZ-P6.b and c.2 and .3- 2. Have regard to the Principles and Outcomes in the Wellington City Council Design Guides Introduction [2022]; and 3. Have regard to standards WFZ-S1 – WFZ-S6. <p>Notification Status: An application for resource consent made in respect of WFZ-R15.6 must be publicly notified.</p>
P1 Sch1		<p>WFZ-R16 Development of new public space, or modification of existing public open space</p>
	Public Open Space	<p>1. Activity status: Discretionary</p> <p>The assessment of the activity must have regard to the Principles and Outcomes in the Wellington City Council Design Guides Introduction [2022].</p> <p>Note this rule does not apply to activities in WFZ-R12, WFZ-R15 or WFZ-R18.</p>
P1 Sch1		<p>WFZ-R17 Conversion of buildings or parts of buildings to residential activities</p>

P1 Sch1

Entire Zone	<p>1. Activity status: Restricted Discretionary</p> <p>Matters of discretion are:</p> <ol style="list-style-type: none"> 1. The extent of compliance with standards WFZ-S3 and WFZ-S4 and associated assessment criteria; 2. The <u>Centres and Mixed Use Residential Design Guide [2022]</u>; 3. The Principles and Outcomes in the Wellington City Council Design Guides Introduction [2022]; 4. The availability and connection existing or planned three waters infrastructure; and 5. The safe movement of people and vehicles to and from the site and within the surrounding area. <p>Notification status: An application for resource consent made in respect of WFZ-R17 is precluded from being either publicly or limited notified.</p>
-------------	--

WFZ-R18	Outdoor storage areas
---------	------------------------------

Entire zone	<p>1. Activity status: Permitted</p> <p>Where:</p> <ol style="list-style-type: none"> a. The storage area is screened by a fence or landscaping of 1.8m in height from any adjoining road or site, <u>and</u>; b. <u>Screening does not obscure emergency or safety signage or obstruct access to emergency panels, hydrants, shut-off valves, or other emergency response facilities.</u>
-------------	---

Entire zone	<p>2. Activity status: Restricted Discretionary</p> <p>Where:</p> <ol style="list-style-type: none"> a. Compliance with the requirements of WFZ-R18.1 cannot be achieved <p>Matters of discretion are:</p> <ol style="list-style-type: none"> 1. The extent to which any lesser screening is necessary to provide for functional or operational requirements of the activities on the site, or for people’s health and safety; and 2. The extent to which outdoor storage is visible to surrounding areas, including any effects on the distinctive form, quality and amenity of the Waterfront Zone. <p>Notification status: An application for resource consent made in respect of rule WFZ-R18.2 is precluded from being publicly and limited notified.</p>
-------------	--

Standards

ISPP

WFZ-S1	Maximum building height outside of Public Open Space and Areas of Change
--------	---

Entire Zone, except Queens Wharf Buildings	<p>Assessment Criteria where the standard is infringed:</p> <ol style="list-style-type: none"> 1. The building at any point does not exceed the height of the existing building heights. <p>Note that new buildings outside of existing building footprints and Queens Wharf Buildings do not have a maximum building height. Instead, each building height must be justified through a discretionary or non-complying consent, with particular regard to Policy 6(b and c)-WFZ-P6.2 and .3.</p>
--	---

Queens Wharf Buildings	2. The building does not exceed 18.1 metres above New Zealand Vertical Datum 2016 (NZVD 2016).	
ISPP	WFZ-S2	Minimum Sunlight Access - Public Space
	<p>1. All buildings or structures within the Waterfront Zone must be designed and located to maintain sunlight access to any area mapped with the specific control "Minimum Sunlight Access - Public Space Requirements", during the time periods specified in Table 1 of Appendix 9;</p> <p>2. For areas in Appendix 9 with a specified time period:</p> <ul style="list-style-type: none"> a. 11:30am-1:30pm; b. 12:00pm-2:00pm; and c. 1:30-3:00pm; and <p>Ssunlight access must be maintained in the entire area during this period.</p> <p>3. For areas in Appendix 9 with a specified time period:</p> <ul style="list-style-type: none"> a. 10:00am-3:00pm; and b. 10:00am-4:00pm; and <p>Ssunlight access must be maintained in a minimum of 70% of the area during this period.</p> <p>This standard does not apply to:</p> <ul style="list-style-type: none"> a. Any temporary structure erected and dismantled in less than 30 days. b. Any public amenity facility erected within an identified public space. 	<p>Assessment criteria where the standard is infringed:</p> <ul style="list-style-type: none"> 1. The extent of increased shadowing and any associated adverse amenity effects on the sunlight access area.
ISPP	WFZ-S3	Outlook space (per residential unit)
	<ul style="list-style-type: none"> 1. An outlook space must be provided for each residential unit as specified in this standard; 2. All habitable rooms must have an outlook space with a minimum dimension of 1m in depth and 1m in width; 3. The width of the outlook space is measured from the centre point of the largest window on the building face to which it applies; 4. Outlook spaces may be over driveways and footpaths within the site or over a public street or other public open space; 5. Outlook spaces may overlap where they are on the same wall plane in the case of a multi-storey building; 6. Outlook spaces may be under or over a balcony; 7. Outlook spaces required from different rooms within the same building may overlap; and 8. Outlook spaces must: <ul style="list-style-type: none"> a. be clear and unobstructed by buildings; and 	<p>Assessment criteria where the standard is infringed:</p> <ul style="list-style-type: none"> 1. The extent of increased shadowing and any associated adverse amenity effects on the sunlight access area <u>1. The extent to which:</u> <ul style="list-style-type: none"> a. <u>Acceptable levels of natural light are provided to habitable rooms;</u> b. <u>The design of the proposed unit provides a healthy living environment; and</u> c. <u>The extent of dominance and privacy related effects on adjoining sites.</u>

ISPP

b. not extend over an outlook space or outdoor living space required by another dwelling.		
WFZ-S4	Minimum residential unit size	
1. Residential units, including any dual key unit, must meet the following minimum sizes:		Assessment criteria where the standard is infringed:
Residential Unit Type	Minimum Net Floor Area	1. The extent to which: <ul style="list-style-type: none"> a. The design of the proposed unit provides a good standard of amenity; and b. Other on-site factors compensate for a reduction in unit sizes.
a. Studio unit	35m ²	
b. 1 bedroom unit	40m ²	
c. 2+ bedroom unit	55m ²	

ISPP

WFZ-S5	Building separation distance	
1. Any new residential building or addition to an existing residential building must provide a 8 m separation distance between buildings located on the same site.		Assessment criteria where the standard is infringed:
		1. The extent to which a reduced setback will increase dominance and shadowing related effects on residential units within the development site.

ISPP

WFZ-S6	Waterfront Zone <u>site-total building coverage</u>	
1. All development must result in the sum of all buildings in the Waterfront Zone having a <u>site-total building coverage</u> of less than 35% of the whole Waterfront Zone.		Assessment criteria where the standard is infringed:
		1. The extent to which an exceedance is temporary, or is not perceived as a dominant above-ground building (for example, a low-level building with easily accessible public space on top).

This entire chapter has been notified using the RMA Part One, Schedule 1 process ([P1 Sch1](#)).

He Rohe Ahumai Whānui

General Industrial Zone

GIZ	General Industrial Zone
------------	--------------------------------

Introduction

The purpose of the General Industrial Zone is to provide predominantly for a range of industrial activities. The Zone is also used for activities that are compatible with the adverse effects generated from industrial activities, as well as ancillary activities.

The General Industrial Zone covers areas which are primarily utilitarian working environments in locations where industrial activities can operate without having to compete for land with, or be interfered with by, non-industrial activities requiring higher amenity standards. To ensure the supply of land available for industrial activities is not reduced, the Council will limit the nature and scale of commercial activities in the General Industrial Zone. Ancillary retail and office activities are recognised as necessary components of areas providing for industrial-based activities. Accordingly, these activities are considered to be appropriate in the General Industrial Zone.

If activities that are sensitive to the nature and scale of effects from industrial activities locate in the General Industrial Zone, the ongoing functional operation of these zones for industrial activities may be compromised. Accordingly, sensitive activities will not be enabled in the General Industrial Zone unless they are ancillary to, or support the functional use of, activities anticipated in the Zone. Such activities will also need to be designed and constructed in a manner that effectively reduces the elevated effects of industrial uses in order to minimise the potential for reverse sensitivity.

Other appropriate retail activities in this Zone include trade supply retail, wholesalers and yard-based retail activities. These activities typically generate less frequent visits as purchase prices are high and the goods for sale are often not consumables but capital assets. Stores selling these products are by necessity large and require extensive building footprints and large servicing and carparking areas. These types of retail activity are considered to complement the activities within established centres.

Compared to Centres and other employment areas, lower levels of amenity are acceptable in the General Industrial Zone. The Council will encourage new development to contribute positively to the local neighbourhood context, while recognising and providing for the operational and functional needs of activities anticipated in the Zone.

Many industrial activities are characterised by moderate to high levels of noise, dust, odour, heavy vehicle trip generation or other environmental effects associated with high-intensity activity. The location of the General Industrial Zone is such that many of these activities can be enabled without concern about their impacts on the surrounding environment; however, more careful management will be required for:

1. New industrial use and development near sensitive activities in other Zones; and
2. Activities that generate adverse effects of a nature or scale that is potentially noxious, objectionable or offensive.

GIZ- PREC01	Miramar/Burnham Wharf Precinct
------------------------	---------------------------------------

Miramar and Burnham Wharf are regionally significant infrastructure located within the Coastal Marine Area.

The purpose of the Miramar/Burnham Wharf Precinct is to enable the continued safe and effective operation of operational port activities ~~the port~~ while regulating the use of this land for activities not related to this established use.

The Miramar/Burnham Wharf operates in close proximity to residential properties in the suburbs of Maupuia and Miramar and the neighbouring residential sites are potentially sensitive to the effects of the nearby port activities.

The provisions of the Zone and Precinct should be read in conjunction. The Zone provisions set the general direction for use and operations of the site for port activities.

Where there is any conflict between the General Industrial Zone provisions and Precinct provisions, the Precinct provisions prevail.

Other relevant District Plan provisions

There may be a number of provisions that apply to an activity, building, structure or site. Resource consent may therefore be required under rules in this chapter as well as other chapters. Unless specifically stated in a rule, resource consent is required under each relevant rule. The steps to determine the status of an activity are set out in the General Approach chapter.

Objectives	
GIZ-O1	<p>Purpose</p> <p>The General Industrial Zone is developed and used primarily for industrial activities and the City’s short, medium and long term needs for land for such activities are met.</p>
GIZ-O2	<p>Sensitive activities</p> <p>Sensitive activities are not established in the General Industrial Zone unless they are necessary for, and do not undermine, the functional operation of industrial activities.</p>
GIZ-O3	<p>Commercial activities</p> <p>Commercial activities are not established in the General Industrial Zone unless they:</p> <ol style="list-style-type: none"> 1. Are ancillary to industrial activities; or 2. Are of a nature and scale that does not undermine the hierarchy of Centres.
<u>GIZ-O4</u>	<p><u>Protection of the General Industrial Zone</u></p> <p><u>Industrial activities and the role and function of the General Industrial Zone are not constrained or compromised by:</u></p> <ol style="list-style-type: none"> <u>1. Incompatible activities and/or reverse sensitivity effects; and</u> <u>2. Activities sensitive to nuisance effects including odour, dust, and noise.</u>
GIZ-O45	<p>Amenity and design</p> <p>The scale, form and design of new development in the General Industrial Zone positively contributes to creating a well-functioning urban environment, and responds to any functional needs or operational needs.</p>
GIZ-O56	<p>Managing effects</p> <p>Adverse effects from use and development of the General Industrial Zone are compatible with the local neighbourhood and managed effectively, particularly in relation to any sensitive activities in neighbouring zones.</p>

Miramar/Burnham Wharf Precinct

<p>GIZ-PREC01-01</p>	<p>Purpose</p> <p>Miramar/Burnham Wharf is used, operated and developed effectively for operational port activities.</p>
<p>Policies</p>	
<p>GIZ-P1</p>	<p>Enabled activities</p> <p>Enable industrial activities in the General Industrial Zone.</p>
<p>GIZ-P2</p>	<p>Heavy industrial activities</p> <p>Only allow heavy industrial activities in the General Industrial Zone where adverse effects on other activities are adequately managed.</p>
<p>GIZ-P3</p>	<p>Sensitive Activities</p> <p>Avoid the establishment of sensitive activities in the General Industrial Zone, unless such activities are:</p> <ol style="list-style-type: none"> 1. Ancillary to a permitted or consented activity on the same site; and 2. Sufficiently insulated <u>or distanced</u> from <u>nuisance effects including odour, dust and</u> noise effects of existing activities or other activities permitted in the Zone.
<p>GIZ-P4</p>	<p>Commercial activities</p> <p>Avoid commercial activities in the General Industrial Zone except for:</p> <ol style="list-style-type: none"> 1. Office, retail and other commercial activities which are ancillary to industrial activities; and 2. Trade supply retail, wholesalers, building improvement centres, service retail and yard based retail.
<p>GIZ-P5</p>	<p>Design of new development</p> <p>Encourage enhancements to local context and amenity, while enabling innovation and choice in the design of new built development and recognising the functional needs and operational needs of industrial activities.</p>
<p>GIZ-P6</p>	<p>Zone interfaces</p> <p>Require uses and developments within the General Industrial Zone to maintain a reasonable level of amenity for adjoining Residential Zones or other sensitive activities.</p>
<p>Miramar/Burnham Wharf Precinct</p>	
<p>GIZ-PREC01-P1</p>	<p>Miramar/Burnham Wharf Precinct</p> <p>Provide for operational port activities in the Miramar/Burnham Wharf precinct and manage the height, bulk and location of buildings and structures in a way that:</p> <ol style="list-style-type: none"> 1. Mitigates any adverse effects on the amenity of nearby residential properties; and 2. Ensures that the height of proposed buildings and structures does not adversely affect the safe and efficient operation of Wellington International Airport.
<p>Land Use Activities</p>	
<p>GIZ-R1</p>	<p>Industrial activities</p>
<p>1. Activity status: Permitted</p> <p>Where:</p>	

	<p>a. The activity is not a heavy industrial activity; and</p> <p>b. Any ancillary retail activity is limited to the display and sale of goods produced, processed or stored on the site and does not exceed 10% of the gross floor area of all buildings on the site.</p>
	<p>2. Activity status: Discretionary</p> <p>Where:</p> <p>a. Compliance with any of the requirements of GIZ-R1.1 cannot be achieved.</p>
GIZ-R2	Trade and industrial training facilities
	<p>1. Activity status: Permitted</p>
GIZ-R3	Emergency service facilities
	<p>1. Activity status: Permitted</p>
GIZ-R4	Community Corrections Activities
	<p>1. <u>Activity status: Permitted</u></p>
GIZ-R45	Commercial activities
	<p>1. Activity status: Permitted</p> <p>Where:</p> <p>a. The activity is trade supply retail, a wholesaler, a building improvement centre, service retail or yard based retail.</p>
	<p>2. Activity status: Non-complying</p> <p>Where:</p> <p>a. Compliance with the requirements of GIZ-R45.1 cannot be achieved.</p>
GIZ-R56	Sensitive activities not ancillary to a permitted activity
	<p>1. Activity status: Non-complying</p>
GIZ-R67	All other activities
	<p>1. Activity status: Discretionary</p> <p>Where:</p> <p>a. The activity is not otherwise provided for as a permitted activity or non-complying activity.</p>
GIZ-R78	Operational port activities
	<p>1. Activity status: Permitted</p> <p>Where:</p> <p>a. The activity is located in the Miramar/Burnham precinct.</p>
	<p>2. Activity status: Non-complying</p> <p>Where:</p> <p>a. Compliance with any of the requirements of GIZ-R78.1 cannot be achieved.</p>
Rules: Building and structure activities	

GIZ-R89	Maintenance and repair of buildings and structures
1. Activity status: Permitted	
GIZ-R910	Demolition or removal of buildings and structures
1. Activity status: Permitted	
GIZ-R1011	Construction of, or additions and alterations to, buildings and structures
1. Activity status: Permitted	
Where:	
a. Compliance with GIZ-S1, GIZ-S3, GIZ-S4, GIZ-S5, and GIZ-S6, and <u>GIZ-S7</u> is achieved.	
2. Activity status: Restricted Discretionary	
Where:	
a. Compliance with any of the requirements of GIZ-R1 01 .1 cannot be achieved.	
Matters of discretion are:	
<ol style="list-style-type: none"> 1. The matters in GIZ-P5 and GIZ-P6; 2. The extent of compliance with GIZ-S2; and 3. The extent and effect of non-compliance with any relevant standard as specified in the associated assessment criteria for the infringed standards. 	
Notification status: An application for resource consent made in respect of rule GIZ-R1 01 .2 that results from non-compliance with GIZ-S1 but that complies with both GIZ-S2 and GIZ-S3 is precluded from being either publicly or limited notified.	
GIZ-R112	Outdoor storage areas
1. Activity status: Permitted	
Where:	
a. The storage area is screened by either a fence or landscaping of at least 1.8m in height high from any adjoining road or site-; and	
b. <u>Screening does not obscure emergency or safety signage or obstruct access to emergency panels, hydrants, shut-off valves, or other emergency response facilities.</u>	
2. Activity status: Restricted Discretionary	
Where:	
a. Compliance with the requirements of GIZ-R1 12 .1 cannot be achieved.	
Matters of discretion are:	
<ol style="list-style-type: none"> 1. The matters in GIZ-P5 and GIZ-P6; 2. The extent to which any lesser screening is necessary to provide for functional needs or operational needs of the activities on the site, or for people's health and safety; and 3. Visual amenity effects. 	
Notification status: An application for resource consent made in respect of rule GIZ-R1 12 .2 is precluded from being publicly or limited notified.	
Rules: Buildings and structures in the Miramar/Burnham Wharf Precinct	

GIZ-PREC01-R1	Construction of, or additions and alterations to, buildings and structures
<p>1. Activity status: Permitted</p> <p>Where:</p> <ul style="list-style-type: none"> a. The building is associated with an operational port activity; and b. Compliance with GIZ-S1, GIZ-S3, GIZ-S4, GIZ-S5 and GIZ-S6 is achieved. 	
<p>2. Activity status: Restricted Discretionary</p> <p>Where:</p> <ul style="list-style-type: none"> a. Compliance with any of the requirements of GIZ-PREC-01-R1.1 cannot be achieved. <p>Matters of discretion are:</p> <ul style="list-style-type: none"> 1. The matters in GIZ-P3, GIZ-P4, GIZ-P5, GIZ-P6 and GIZ-PREC01-P1; 2. The extent and effect of non-compliance with any relevant standard as specified in the associated assessment criteria for the infringed standards; and 3. In the Miramar/Burnham Wharf precinct, the height of construction related equipment and the construction methodology proposed to ensure no penetration of the airspace height restriction in Designation WIAL1. <p>Notification Status: An application for resource consent made in respect of rule GIZ-PREC01-R1.2 is precluded from being publicly notified.</p>	

Standards

GIZ-S1	Maximum height of buildings and structures for the purpose of GIZ-R10.1 and GIZ-PREC01-R1.1
---------------	--

<p>1. Buildings and structures must comply with the following maximum height limits above ground level:</p>	<p>Assessment criteria where the standard is infringed:</p> <ul style="list-style-type: none"> 1. The extent to which the additional height is necessary to provide for functional needs or operational needs of the activities on the site; 2. Visual and amenity effects; 3. Dominance, privacy and shading effects on adjoining sites; and 4. Proximity of the building to any Residential Zone, Open Space and Recreation Zone or sensitive activities in other zones and the extent to which the separation distance mitigates the effects of the additional height. 								
<table border="1" style="width: 100%;"> <thead> <tr> <th style="width: 30%;">Location</th> <th style="width: 25%;">Limit</th> </tr> </thead> <tbody> <tr> <td> Height Control Area 1 Southern Landfill Rongotai East Miramar south Tawa street <u>Tawa Street and Main Road</u> Glenside Area 1A, Area 1B and Area 2 Miramar/Burnham wharf precinct Moa Point </td> <td>12 metres</td> </tr> <tr> <td> Height Control Area 2 Tawa: Collins Avenue Newlands Kaiwharawhara Lincolnshire Farm <u>Grenada Village</u> </td> <td>15 metres</td> </tr> <tr> <td> Height Control Area 3 Grenada North Ngauranga Newlands </td> <td>18 metres</td> </tr> </tbody> </table>	Location	Limit	Height Control Area 1 Southern Landfill Rongotai East Miramar south Tawa street <u>Tawa Street and Main Road</u> Glenside Area 1A, Area 1B and Area 2 Miramar/Burnham wharf precinct Moa Point	12 metres	Height Control Area 2 Tawa: Collins Avenue Newlands Kaiwharawhara Lincolnshire Farm <u>Grenada Village</u>	15 metres	Height Control Area 3 Grenada North Ngauranga Newlands	18 metres	
Location	Limit								
Height Control Area 1 Southern Landfill Rongotai East Miramar south Tawa street <u>Tawa Street and Main Road</u> Glenside Area 1A, Area 1B and Area 2 Miramar/Burnham wharf precinct Moa Point	12 metres								
Height Control Area 2 Tawa: Collins Avenue Newlands Kaiwharawhara Lincolnshire Farm <u>Grenada Village</u>	15 metres								
Height Control Area 3 Grenada North Ngauranga Newlands	18 metres								

Area 1A and 1B Miramar/Burnham wharf precinct (buildings and structures associated with operational port activities only) Hyde Farm		
2. Fences and standalone walls must not exceed a maximum height of 1.8 metres (measured above ground level). This standard does not apply to: a. Cranes, elevators and similar cargo handling equipment and lighting poles in the Miramar/Burnham Wharf precinct.		
GIZ-S2	Maximum height of buildings and structures for the purpose of GIZ-R10.2 and GIZ-PREC01-R1.2	
1. Buildings and structures must comply with the following maximum height limits above ground level:		Assessment criteria where the standard is infringed:
Location	Limit	<ol style="list-style-type: none"> 1. The extent to which the additional height is necessary to provide for functional needs or operational needs of the activities on the site; 2. Visual and amenity effects; 3. Dominance, privacy and shading effects on adjoining sites; and 4. Proximity of the building to any Residential Zone, Open Space and Recreation Zone or sensitive activities in other zones and the extent to which the separation distance mitigates the effects of the additional height.
Height Control Area 1 Southern Landfill Rongotai East Miramar South Glenside Area 1A, Area 1B and Area 2 Miramar/Burnham wharf precinct Moa Point Lincolnshire Farm Grenada Village	18 metres	
Height Control Area 2 Area 1B Miramar/Burnham wharf precinct (buildings and structures associated with operational port activities only)	21 metres	
Height Control Area 3 Tawa S street and Main R oad	22 metres	
Height Control Area 4 Tawa: Collins Avenue Newlands Kaiwharawhara	22.5 metres	
Height Control Area 5 Ngauranga Newlands Grenada North Area 1A Miramar/Burnham wharf precinct (buildings and structures associated with operational port activities only) Hyde Farm	24 metres	

GIZ-S3	Height in relation to boundary		
<p>1. No part of any building or structure may project beyond the relevant recession plane shown below:</p>			<p>Assessment criteria where the standard is infringed:</p> <ol style="list-style-type: none"> 1. The extent to which any infringement is necessary to provide for functional or operational needs of the activities on the site; 2. Dominance, privacy and shading effects on adjoining sites; 3. Whether topographical or other site constraints make compliance with the standard impracticable; and 4. The effect on the function and associated amenity values of any adjacent Open Space Zone.
Location	Recession Plane		
Boundary adjoining any site within the MRZ with a height limit of 11m identified on the District Plan Maps	60° measured from a height of 4m vertically above ground level		
Boundary adjoining any site within the MRZ with a height limit of 14m identified on the District Plan Maps	60° measured from a height of 5m vertically above ground level		
Boundary adjoining any site within the HRZ	60° measured from a height of 8m vertically above ground level		
Boundary adjoining any site within an Open Space Zone	60° measured from a height of 5m vertically above ground level		
<p>These standards do not apply to:</p> <ol style="list-style-type: none"> a. A boundary with a road; b. Internal boundaries; c. Fences or standalone walls no greater than 1.8m metres in height where these are not for the purpose of screening an outdoor storage area; d. Solar power or heating components provided these do not exceed the height in relation to boundary by more than 500mm measured vertically; e. Satellite dishes, antennas, aerials, chimneys, flues, architectural or decorative features (e.g. finials, spires) provided that none of these exceed 1m in diameter and do not exceed the height in relation to boundary by more than 3m measured vertically; and f. Lift overruns, provided these do not exceed the height in relation to boundary by more than 1m measured vertically. 			
GIZ-S4	Maximum gross floor area		
<p>1. The maximum gross floor area on any site adjoining any Residential Zone must not exceed 4,000m².</p>			<p>Assessment criteria where the standard is infringed:</p> <ol style="list-style-type: none"> 1. The extent to which the additional floor area is necessary to provide for functional needs or operational needs of the activities on the site; and 2. Dominance, privacy, and shading effects on adjoining sites.
GIZ-S5	Windows adjacent to Residential Zones		

<p>1. Opaque privacy glazing must be installed in windows where:</p> <ul style="list-style-type: none"> a. Above ground floor level; and b. The associated building wall faces a site in any Residential Zone; and c. The wall is located within 5m of the boundary of a site in any Residential Zone. 	<p>Assessment criteria where the standard is infringed:</p> <ul style="list-style-type: none"> 1. Privacy effects on adjoining sites; and 2. Positive safety implications of over-looking public space.
<p>GIZ-S6 Verandah control</p>	
<p>1. Any verandah constructed on any building frontage facing a public space must:</p> <ul style="list-style-type: none"> a. Have a minimum clearance of 2.5m directly above the footpath or formed ground surface, measured from the base of the veranda fascia; b. Be no more than 4m directly above the footpath or formed ground surface, measured from the base of the verandah fascia; c. Be setback a minimum horizontal distance of 450mm from any kerbing extending to the site boundary; and d. Extend no more than 3m from the front of the building, measured horizontally. 	<p>Assessment criteria where the standard is infringed:</p> <ul style="list-style-type: none"> 1. The extent to which any non-compliance is necessary to provide for functional needs or operational needs of the activities on the site, or for people's health and safety; 2. Whether sufficient clearance is provided for pedestrians and the delivery of goods where any verandah is proposed lower than 2.5m above the footpath or ground surface level; and 3. The extent to which any verandahs wider than 3m or within 450mm of any kerbing allow clearance for unencumbered vehicle movement, parking and loading.
<p>GIZ-S7 Boundary setbacks from a rail corridor</p>	
<p>1. <u>Buildings or structures must not be located within a 1.5m setback from a rail corridor boundary.</u></p>	<p>Assessment criteria where the standard is infringed:</p> <ul style="list-style-type: none"> 1. <u>The extent to which the location and design of the building relates to the ability to safely use, access and maintain buildings without requiring access on, above or over the rail corridor.</u>

This entire chapter has been notified as part of an Intensification Planning Instrument, using the Intensification Streamlined Planning Process (ISPP) in accordance with Section 80E of the RMA.

He Rohe Whanake: Ngā Whare Pāhi o Kilbirnie

Development Area: Kilbirnie Bus Barns

DEV1	Development Area – Kilbirnie Bus Barns
-------------	---

Introduction

The 'Bus Barns' site in Kilbirnie has the potential to be developed into a high quality mixed-use development. The provisions contained in this Development Area will guide the future comprehensive redevelopment of the site from its current use as a bus depot, should this transition occur.

The Bus Barns site includes the Metropolitan Centre Zone land bound by Onepu Road, Endeavour Street, Ross Street and Coutts Street, title WN58A/1.

Eight residential zoned properties all zoned Medium Density Residential Zone (52-58, 62-64 and 85 Ross St and 47 Endeavour Street, and 73 Onepu Road are also part of the current Kilbirnie Bus Barn operations. The provisions of the Development Area do not apply to these sites, but are identified in the Development Plan as they may be involved in future works.

The provisions do not affect the current use of the site as a bus depot. In the event that the site is redeveloped for use as a bus depot the Development Area provisions would not apply. In those circumstances the provisions of the Metropolitan Centre Zone would apply.

The Development Area provisions apply in addition to those of the Metropolitan Centre Zone. Where there are any inconsistencies between the underlying zoning and the provisions in this Development Area chapter, the provisions in this chapter shall prevail.

Other relevant District Plan provisions

There may be a number of provisions that apply to an activity, building, structure or site. Resource consent may therefore be required under rules in this chapter as well as other chapters. Unless specifically stated in a rule, resource consent is required under each relevant rule. The steps to determine the status of an activity are set out in the General Approach chapter.

Objectives	
DEV1-O1	<p>Purpose</p> <p>High quality mixed use development is achieved on the Kilbirnie 'Bus Barns' site through a comprehensive development process.</p>
Policies	
DEV1-P1	<p>Comprehensive Development of the Bus Barns site</p> <p>Provide flexibility for development and subdivision of the Kilbirnie 'Bus Barns' site, while ensuring that development is undertaken in general accordance with the development principles of the Development Plan.</p>

Rules: Land use activities**DEV1-R1****Construction of, or additions and alterations to, buildings and structures**1. Activity status: **Permitted**

Where:

- a. Any alterations or additions to a building or structure that:
 - i. Do not alter the external appearance of the building or structure; or
 - ii. Relate to a building frontage below verandah level, including entranceways and glazing; or
 - iii. Are not visible from public spaces; and
 - iv. Results in the creation of new residential units; and
 - v. Comply with standards MCZ-S1, MCZ-S2, MCZ-S3, MCZ-S4, MCZ-S5, and MCZ-S6; or
- b. The construction of any building or structure:
 - i. Is not located on a site with an active frontage or non-residential activity frontage; ~~or and~~
 - ii. Is not visible from public space; and
 - iii. Will have a gross floor area of less than 100m²; and
 - iv. Will result in a total coverage (together with other buildings) of no more than 20 percent of the site; and
 - v. Comply with standards MCZ-S1, MCZ-S2, MCZ-S3, MCZ-S4, MCZ-S5, and MCZ-S6; and
 - vi. Does not involve the construction of a new building for residential activities.

~~4.~~ 2. Activity status: **Restricted Discretionary**

Where:

- a. Compliance with any of the requirements of DEV1-R1.1 cannot be achieved.

Matters of discretion are:

1. The matters in DEV1-P1, MCZ-P6, MCZ-P7, MCZ-P8 and MCZ-P9;
2. The extent and effect of non-compliance with MCZ-S1, MCZ-S2, MCZ-S3, MCZ-S4, MCZ-S5, MCZ-S6, MCZ-S7, MCZ-S8, MCZ-S9, MCZ-S10 and MCZ-S11;
- ~~3. The Centres and Mixed-Use Design Guide, including guideline G107 - City Outcomes Contribution as required in Appendix 16 for any building that exceeds the MCZ-S1 height requirement threshold and is under the minimum height and either comprises 25 or more residential units or is a non-residential building;~~
3. ~~3. The Residential Design Guide;~~
4. ~~4.~~ The extent and effect of any identifiable site constraints;
5. ~~5.~~ Construction impacts on the transport network;
6. ~~6.~~ The extent of compliance with the Kilbirnie Bus Barns Development Plan; and
7. ~~7.~~ The availability and connection to existing or planned three waters infrastructure.

Notification status:

An application for resource consent made in respect of rule MCZ-~~R2120~~.2 that complies with MCZ-S3, MCZ-S7, MCZ-S8, MCZ-S9, MCZ-S10 and MCZ-S11 is precluded from being either publicly or limited notified.

An application for resource consent made in respect of rule MCZ-~~R2120~~.2 that results from non-compliance with MCZ-S1, MCZ-S2, MCZ-S4, MCZ-S5 and MCZ-S6 is precluded from being publicly notified.

This entire chapter has been notified as part of an Intensification Planning Instrument, using the Intensification Streamlined Planning Process (ISPP) in accordance with Section 80E of the RMA.

APP8 – Rangahau Inerahi ā-Hau me te Aromatawai Inekounga ā-Hau - Ngā Herenga mō te Whakatauiratanga me te Tuku Pūrongo

APP8 – Quantitative Wind Study and Qualitative Wind Assessment – Modelling and Reporting Requirements

This appendix details the requirements for both quantitative wind studies and qualitative wind assessments in accordance with the Wind Chapter requirements.

Rule WIND-R1 details the height thresholds and development triggers when either a qualitative or quantitative wind assessment is required to show compliance with standards WIND-S1, WIND-S2 and WIND-S3 as relevant.

~~For the City Centre Zone, Metropolitan Centre Zone—Height Control Area 1, Special Purpose Port Zone, Multi-User Ferry Precinct, Inner Harbour Port Precinct, Special Purpose Stadium Zone and Special Purpose Waterfront Zone, a quantitative wind study will usually be required to show compliance with the wind standards. Council may accept a qualitative wind assessment when a development is likely to have little, if any, impact on wind conditions—refer to the Wind Chapter Best Practice Guidance Document (Appendix 14) for likely wind effects of buildings.~~

~~For the Local Centre Zone, Neighbourhood Centre Zone, Metropolitan Centre Zone—excluding Metropolitan Centre Zone Height Control Area 1, Special Purpose Hospital Zone and Special Purpose Tertiary Education Zone a qualitative wind assessment is usually all that is required to show compliance with the wind standards. However, if a development is assessed to have a large negative impact on wind conditions, then a quantitative wind study may be required to enable the wind effects of the development to be fully understood.~~

~~It is up to the discretion of the resource consent planner to decide whether a quantitative wind study or a qualitative wind assessment is required.~~

Appendix 8 Wind-A1: Modelling and reporting requirements for a Quantitative Wind Study

This Appendix details the minimum requirements for quantitative wind studies required by rules in the Wind Chapter.

1 Aims of a wind study

The aims of a wind study are:

- 1.1 To quantify the extent and magnitude of the effect of a building proposal on the surrounding pedestrian level wind environment by measuring and comparing the existing and proposed wind conditions;
- 1.2 To provide documentary evidence of the proposed building's effect on the local wind environment and level of compliance with the wind standards; and
- 1.3 To demonstrate, where the proposed building will cause wind conditions to deteriorate, to show that every reasonable alternative design has been explored and that the proposed building is the best practical aerodynamic design for the site.

2 Minimum requirements for a wind tunnel study

Wind tunnel studies must meet the following conditions:

- 2.1 Wind studies must comply with the requirements of Australasian Wind Engineering Society Quality Assurance Manual, Wind Engineering Studies of Buildings, AWES-QAM-1-2019, except where the rules and requirements of the Wind Chapter supersede them.
- 2.2 The model scale used in the wind tunnel test must not be smaller than 1:300.
- 2.3 The atmospheric boundary-layer simulation must represent the local upwind terrain, as defined in the Australia/New Zealand Loading Standard, AS/NZS 1170.2:2021.
- 2.4 All wind speeds must be measured at a full-scale height of 2 metres.
- 2.5 Wind speeds must be measured for wind directions at no greater than 20° intervals for the prevailing wind directions at the site. The measurements must be scaled to full-scale wind speeds using reference wind data corresponding to 20° sectors.
- 2.6 For Wellington CBD, reference wind conditions have been measured in a previous study (refer Jackson, P. S.: 1976, 'Thorndon Wind Tower. Part I: Data Collection; Part 2: Wind Structure', N.Z. Ministry of Works and Development, Central Laboratories Rept. 3-76/4), and are derived from Wellington Airport wind data, with the following corrections applied:
 - a. Winds at a height of 10m at Wellington Airport have an equivalent mean speed to winds at a height of 150m above Wellington City, and
 - b. Wind directions over Wellington City are the same as those at Wellington Airport, except that the northerly wind directions (i.e. 0°-80° and 280°-360°) are rotated to the west by 10° (e.g. 360° at the airport becomes 350° over the city).
- 2.6.1 For the Wellington CBD, the following reference mean speeds and wind directions are derived from the Wellington Airport data (1985-1998), using the corrections in a) and b) above. The reference wind speeds correspond to the annual maximum hourly mean wind speeds at a height of 150m

150° 15m/s	170° 20m/s	190° 22m/s	210° 22m/s
320° 19m/s	340° 22m/s	360° 20m/s	020° 15m/s

2.6.2 For Wellington CBD, the hours of occurrence of the hourly mean wind speeds must be derived using wind data from Wellington Airport with the corrections described in a and b above.

2.7 The annual maximum gust speeds in WIND-S1 must be calculated from measurements at each location for each wind direction, using the following equation:

$$\text{gust} = v + 3.7\sigma,$$

where v = the annual maximum hourly mean wind speed for the particular wind direction and

σ = the standard deviation of the wind speed.

For Wellington CBD, the reference wind speeds and wind directions in 2.6.1 must be used to derive the annual maximum gust speeds.

2.8 The number of hours that the hourly mean wind speed equals or exceeds 2.5 m/s in a year must be calculated to assess compliance with WIND-S1, WIND-S2, and where applicable WIND-S3. For Wellington CBD, the reference wind data in 2.6.2 must be used to derive the number of hours, equalled or exceeded.

2.9 Flow visualisation tests of the existing situation and of the proposed development must be undertaken. Results from the testing must show the full spatial extent of any change in wind conditions with the proposed building and the spatial extent of windy areas around the development site. At a minimum, flow visualisation must show effects on:

- a. Two building heights upwind of the site; and
- b. Four building heights either side of the site; and
- c. Six building heights downwind.

The testing must produce at least six different wind speed contours, and be undertaken for at least two representative northerly wind directions and two representative southerly wind directions that show the likely worst wind effects.

2.10 Where the standards WIND-S1, WIND-S2, or where applicable WIND-S3, are not complied with, and evidence for applying discretion is required, alternative building designs and/or modifications must be investigated to demonstrate that the proposed building is the best practical attempt to comply with the wind standards. While the investigation of alternative designs need only focus on those areas, and those wind directions, where non-compliance occurs, sufficient measurements must be taken elsewhere to quantify all the significant changes in wind conditions with the alternative designs (i.e. measurements must not provide a misleading picture of the overall effect of any building configuration by ignoring public spaces where significant changes in wind speeds occur).

2.10.1 Where the standards WIND-S1, WIND-S2, or where applicable WIND-S3, are not complied with because the wind conditions for the existing situation are already non-compliant, and v

conditions cannot be practically improved by changing the design of the proposed building example, because wind conditions are too far away to be influenced by the design), an analysis of the wind tunnel data must be provided to demonstrate this.

3 Form of wind tunnel test report

A wind tunnel test report must contain:

- 3.1 A description of the atmospheric boundary layer simulation that is used in the wind tunnel, including plots of the mean wind speed profile and turbulence intensity profile.
- 3.2 A description of the reference wind speeds used to derive the wind speeds listed in the wind report. Any assumptions and limitations of the reference wind speed analysis and a description of the meteorological data used must be provided.
- 3.3 A calibration section, which contains the results of flow visualisation tests of a calibration building model, performed using the same wind tunnel setup and procedures as those used for the wind study. The calibration building model must be an isolated square prism, 15 metres square in plan and 60 metres high, at the same model scale used for the wind study. Flow visualisation erosion testing must use at least six different wind speeds, and the final wind speed must correspond to an area of influence (identified by the flow visualisation) equal to 80% of a circular area centred on the back face of the model, with a full-scale diameter of 50 m diameter. The intermediate speeds will be chosen to equally divide this maximum speed.
- 3.4 An analysis of the error limits and the precision that is achievable in the wind speeds and the frequency of occurrence that are listed in the wind report. The relationship of the model (wind tunnel) to full-scale Wellington conditions, as far as it is known, should also be documented through reference to externally refereed papers or reports.
- 3.5 A diagram that clearly shows and identifies the locations/areas that were measured during testing.
- 3.6 A table of the annual maximum gust wind speeds for each wind direction, measurement location, and each building configuration. This will include listings for the existing situation as well as the proposed building configuration(s).
- 3.7 A table of number of hours that the mean hourly wind speed equals or exceeds 2.5 m/s each year, for each measurement location and each building configuration. This will include listings for the existing situation as well as the proposed building option(s).
- 3.8 Records/diagrams of the flow visualisation tests.
- 3.9 A description of the effects of the proposed development on wind conditions in the surrounding area. This must include a description of the 3-dimensional wind flows around the proposed building, indicating the way these wind flows affect pedestrian-level winds. This should clarify:
 - 3.9.1 The cause(s) of any observed non-compliance with the wind standards - WIND-S1, WIND-S2 and WIND-S3;
 - 3.9.2 The ways in which the wind problems might be avoided; and
 - 3.9.3 The ways in which these wind problems might be mitigated.

Notes

For example, at its simplest this might be a statement that:

- The root cause is the downwash caused by the proposed building being very much bigger in scale than its neighbours;
- Reducing the size of the proposed building would remove this root cause; and
- Large canopies around the proposed building could provide shelter from the downwash in the immediate vicinity of the entry ways, although this may result in the carparking area beyond the canopy being made uncomfortable.

3.10 Where the standards WIND-S1, WIND-S2, or where applicable WIND-S3, are not complied with, results of wind tunnel tests of alternative building designs and/or modifications must be provided to show the proposed building is the best practical attempt to achieve these standards. Results for the alternative designs and/or modifications need only be for those areas, and for those wind directions, where problems have been identified. However, sufficient measurements must be taken to quantify all the changes with the alternative designs and/or modifications.

3.11 Where the standard WIND-S1, or where applicable WIND-S3, is not complied with because the existing wind conditions already do not comply, an analysis of the wind tunnel results must be provided to show that the existing wind conditions cannot be practically improved by changing the design of the proposed building. For example, the location of the proposed building could be too far away to influence the windy location or the wind is channeled along the street. and no modification of bulk or form could alter the wind flow.

4 Modelling and reporting requirements for CFD (Computational Fluid Dynamics) Studies

CFD studies must meet the following conditions:

4.1 CFD modelling must meet the requirements of section 2, except that 2.2 is replaced with the requirement to model wind flows and buildings at full-scale. Requirements written for wind tunnel testing (for example “measurements”) must be interpreted and applied to CFD modelling so that an equivalent quality and accuracy is achieved in the model output.

4.2 CFD modelling must resolve unsteady, three-dimensional wind flows through small spaces (i.e. less than 0.5 metres in dimension) at locations where wind speeds are affected by the proposed development. The density of the mesh/cells used in the CFD modelling may be optimised by increasing mesh/cell spacing further from the proposed development, but must remain sufficiently dense to accurately resolve turbulent wind flows affected by the proposed development.

4.3 A suitable turbulence model must be used that can accurately predict gust wind speeds with an averaging period of 3 seconds. The gust equivalent mean (GEM) speed, or other approximations based on the mean wind speed, must not be used to estimate the gust wind speeds in WIND-S1.

A CFD report must contain:

4.4 All information and reporting required in section 3. Requirements in section 3 that are written for wind tunnel testing must be interpreted and applied to the CFD modelling so that equivalent information is available for quality assurance checking and interpretation of the CFD output.

4.5 Documentation of the turbulence model and the rationale for its selection through reference to externally refereed papers or reports.

- 4.6 A validation section, which provides a comparison of the CFD predictions of high rise cases D, E or F in the Architectural Institute of Japan publication “Benchmarks for Validation of CFD Simulations Applied to Pedestrian Wind Environment around Buildings” (2016) and the corresponding benchmark data. The benchmark data is available at https://www.aij.or.jp/jpn/publish/cfdguide/index_e.htm . The difference between predicted and benchmark values must on average be less than 10%, with a maximum difference of 15% in parts of the wake of the taller buildings.
- 4.7 Plots or tables of convergence and stability parameters to demonstrate that the output of each simulation used in the study is stable and converged throughout the flow-field.

Appendix 8 Wind-A2: Reporting requirements for a Qualitative Wind Assessment

This Appendix describes the form and content of qualitative wind assessments, required by rules in the Wind Chapter.

1 Form of Qualitative Wind Assessment Report

A qualitative wind assessment report is not based on the results of a wind tunnel test. It is based on and so ultimately relies on a wind specialist’s expert knowledge of the interaction of buildings with the wind, and of any prior evidence of local wind speeds. It must contain the following:

- 1.1 A description of the existing wind conditions, including sources and limitations of information used in the assessment. Results from previous quantitative wind studies, in the vicinity of the development site, should be used when available.
- 1.2 A description of the interaction of the existing buildings with the wind that leads to the existing wind conditions.
- 1.3 A review of the design of the proposed development, and its appropriateness for a windy environment, including a description of how the scale and form of the proposed building relates to the prototypical building forms documented in the Wind Chapter Best Practice Guidance Document.
- 1.4 A description of the influence of the proposed development on pedestrian level wind speeds in public areas, and its compliance with standards WIND-S1, WIND-S2, and where required WIND-S3. This part of the assessment should, where possible, be quantified by comparison with the wind effects of the prototypical buildings documented in the Wind Chapter Best Practice Guidance Document.
- 1.5 A discussion of the building design and the effectiveness of wind mitigation measures is recommended when the proposed development will lead to a deterioration in the existing wind conditions., The wind assessment must be based as far as possible on the data in the wind design guide, and must provide a clear rationale that the proposed design is the best practical aerodynamic design to achieve compliance with standards WIND-S1, WIND-S2, and where required WIND-S3.
- 1.6 A statement at the conclusion of the report that assesses the proposed developments level of compliance in the professional opinion of the wind specialist, with standards WIND-S1, WIND-S2, and where required WIND-S3.

This entire chapter has been notified as part of an Intensification Planning Instrument, using the Intensification Streamlined Planning Process (ISPP) in accordance with Section 80E of the RMA.

APP9 – Te Rohe Pokapū o te Tāone me te Rohe Tāhuna Kaupapa Ahurei - Te Uru Mōkito e taea ana e te Rā - Ngā Herenga o Ngā Wāhi Tūmatanui

APP9 – City Centre Zone and Special Purpose Waterfront Zone – Minimum Sunlight Access and Wind Comfort Control – Public Space Requirements

City Centre Zone and Special Purpose Waterfront Zone – Minimum Sunlight Access (CCZ-S6 and WFZ-S2) and Wind Comfort Control (WIND-S3)– Public Space Requirements

This appendix and the requirements set out within it apply to the City Centre Zone and Special Purpose Waterfront Zone and relates to and is to be read in conjunction with CCZ-S6, WFZ-S2 and WIND-S3 - minimum sunlight access and wind comfort – public space standards.

Public space location	Zone	Time period to be calculated using New Zealand Standard Time at either of the equinoxes (i.e. 21 March or 23 September 2023)
Pedestrian Malls in the City Centre Zone:		
Cuba Mall	City Centre	11.30am to 1.30pm
Manners Mall	City Centre	1.30pm to 3.00pm
Parks and squares:		
Parks and Squares in the City Centre Zone:		
Thorndon		
Katherine Mansfield Memorial Park	City Centre	10.00am to 4.00pm
Hungarian Garden (Called	City Centre	12.00pm to 2.00pm

“Magyar Millennium Park”)		
Pipitea		
NZ Parliament Grounds – Green space within Parliament Precinct facing Molesworth Street	City Centre	10.00am to 4.00pm
Waititi Landing (ANZAC Corner)	City Centre	10.00am to 4.00pm
The Cenotaph – War Memorial Park	City Centre	10.00am to 4.00pm
Railway Station Forecourt	City Centre	10.00am to 4.00pm
Wellington Central		
Midland Park	City Centre	12.00pm to 2.00pm
Civic Square	City Centre	10.00am to 4.00pm
Te Aro		
Denton Park	City Centre	12.00pm to 2.00pm
Flagstaff Hill/Terrace Gardens	City Centre	12.00pm to 2.00pm
Glover Park	City Centre	12.00pm to 2.00pm
Volunteer Corner	City Centre	11.30am to 1.30pm
Te Niho Park	City Centre	12.00pm to 2.00pm
Cobblestone Park	City Centre	12.00pm to 2.00pm
Te Aro Park	City Centre	12.00pm to 2.00pm
‘Clock Park’ Southeast corner Courtenay Place/ Taranaki Street intersection	City Centre	12.00pm to 2.00pm
Frederick Street Site	City Centre	12.00pm to 2.00pm
Pukeahu National War Memorial Park	City Centre	10.00am to 4.00pm
Basin Reserve	City Centre	10.00am to 4.00pm
Parks and Squares in the Special Purpose Waterfront Zone:		
Kumutoto Park	Waterfront	12.00pm to 2.00pm
Post Office Square	Waterfront	12.00pm to 2.00pm
Frank Kitts Park	Waterfront	10.00am to 4.00pm
Taranaki St Wharf/Lagoon Area	Waterfront	12.00pm to 2.00pm
Te Papa East green space	Waterfront	10.00am to 3.00pm
Waitangi Park	Waterfront	10.00am to 4.00pm
Clyde Quay Park	Waterfront	12.00pm to 2.00pm

This entire chapter has been notified as part of an Intensification Planning Instrument, using the Intensification Streamlined Planning Process (ISPP) in accordance with Section 80E of the RMA.

APP11 – Te Mahere Whakawhanake i ngā Whare Pahi o Killbirnie

APP11 – Kilbirnie Bus Barns Development Plan

Development Plan

Requirements for Kilbirnie Bus Barns Development Area	
DEV1-APP-R1	The transition of the site from a bus depot to a mixed use development will be managed to ensure the quality of existing bus services for the public are not compromised.
DEV1-APP-R2	Demolition and redevelopment phases shall be managed to avoid any potential risks associated with site contamination and hazardous substances. The site, or parts of the site, should not be left vacant in order to: <ol style="list-style-type: none"> 1. Avoid negative impacts on the amenity of adjacent residential areas and the Kilbirnie town centre; 2. Maintain the vitality and viability of the town centre as an attractive place in which to invest and undertake shopping and other community related activities; and 3. Avoid risks associated with vandalism and tagging, fire, or other hazardous activities.
DEV1-APP-R3	Large format retail activities shall not be provided due to their potential to negatively impact the viability and vitality of the existing Kilbirnie Centre area at Bay Road, Coutts Street, and Rongotai Roads.
DEV1-APP-R4	Frontages identified as non-residential activity frontages must comprise non-residential activity at ground floor and not create a featureless façade.
DEV1-APP-R5	The western façade of Barns 2 and 3 (towards Onepu Road) and three sides of the southern-most bay of the main workshop (that is, the façade which abuts the drainage easement and associated east and west facades) should be retained and incorporated into the design of the new development. These protected facades are indicated on the Development Plan.
DEV1-APP-R6	A public open space area for passive recreation activities shall be provided adjacent to the Onepu Road frontage or in a location that is easily accessible to the public. This public open space shall: <ol style="list-style-type: none"> 1. Be designed to a high standard to enable all year around recreational use; 2. Have good access to sunlight; 3. Incorporate tree planting and/or other features to provide wind protection; and 4. Be adjacent to buildings with active edges.
DEV1-APP-R7	A public, mid-block pedestrian and vehicular link shall be provided to connect Onepu Road and Ross Street, and to provide access to commercial and residential units as

	<p>indicated in the Development Plan.</p> <p>The layout and design of the internal road and pedestrian link shall be in general accordance with the Concept Plan, but depending on the final design and layout of development on the site it may not be possible to provide 'active edges' strictly in accordance with District Plan definition along the full length of the internal road. Access into and from the site shall be confined to the points indicated on the concept plan in order to ensure traffic, cyclist, and pedestrian safety and efficiency.</p>
DEV1-APP-R8	Where carparking is provided it shall be located in underground carparks, in undercrofts, garages or in carparking building(s).
DEV1-APP-R9	Development should be designed to allow good quality pedestrian and cycle only access to the Council's drainage easement, which will be developed as a community recreational space. No vehicular access will be permitted across the drainage reserve.

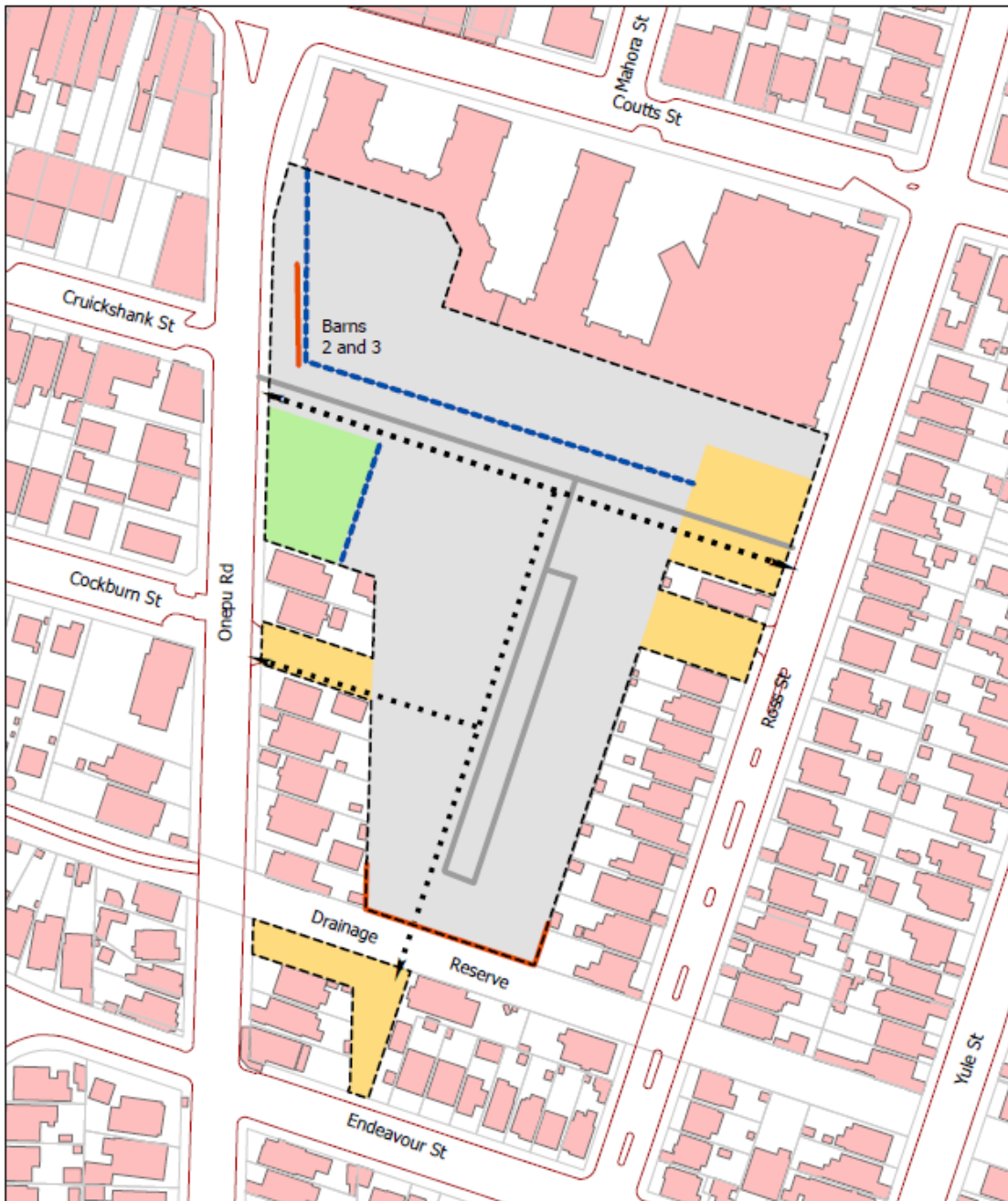

**BUS BARN -
CONCEPT PLAN**

- LEGEND**
- Bus barn site boundary
 - ~~27m maximum building height~~ 35m maximum building height
 - Area subject to Medium Density Residential Area Provision
 - Public Open Space
 - Pedestrian link
 - Indicative vehicular access
 - Retain existing building facades
 - Non-residential frontage

Wind Chapter Best Practice Guidance

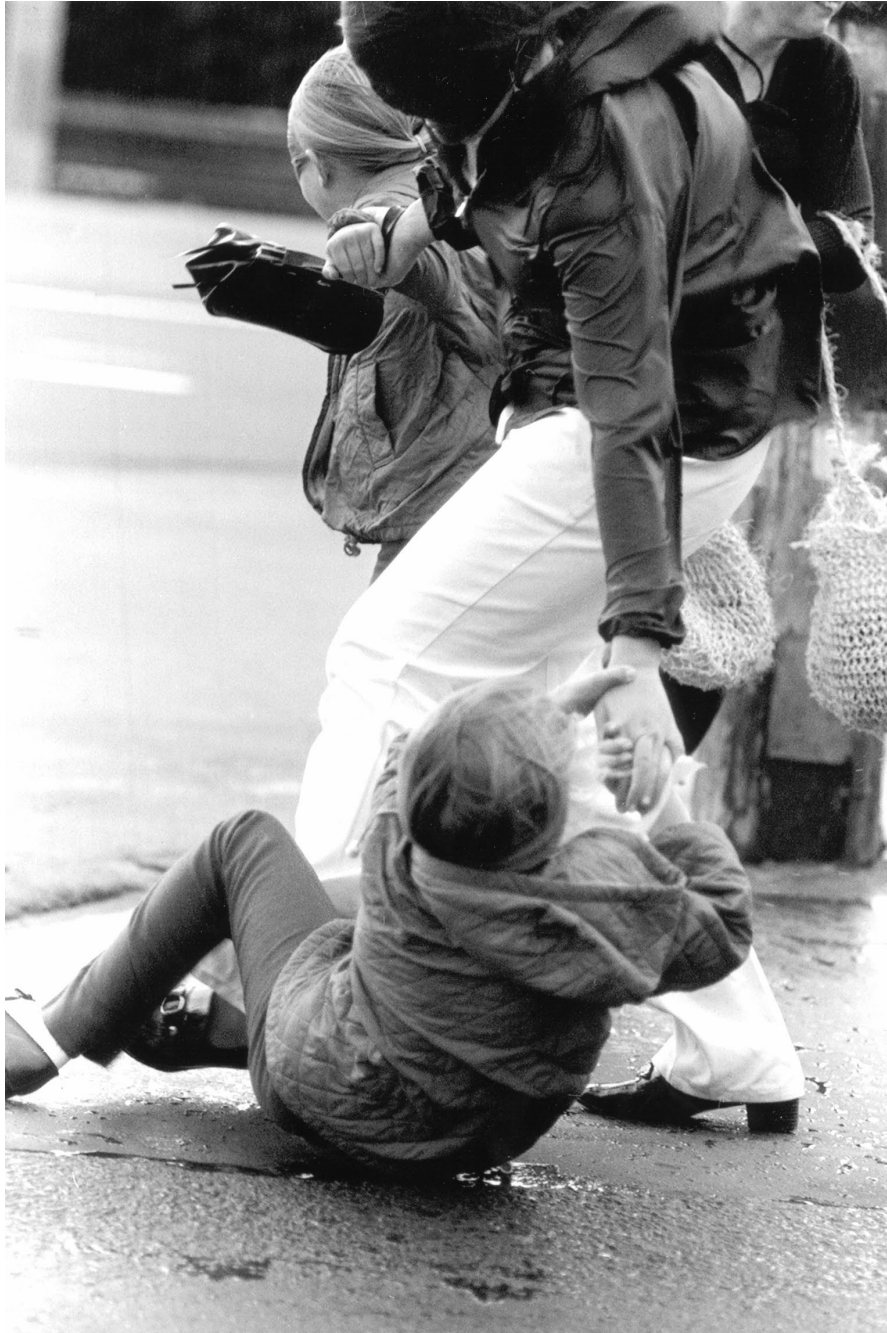

Figure 1 Evening Post photograph 1971

Contents

1.0 Purpose of this Best Practice Guide	5
2.0 Introduction	6
2.1 Wellingtons’ wind climate/environment	6
2.2 The basics of wind flow	6
2.2.1 The built environment.....	6
2.3 Effects of building form on ground-level wind conditions/environment	8
2.3.1 Considering wind early in the planning and design phase	8
3.0 Wind controls in the District Plan	10
3.1 How the Wellington City District Plan wind controls work	10
3.2 Triggers for wind controls	11
3.3 Building configurations	12
3.4 Application of discretion in assessment of wind impacts	13
3.5 Safety	13
3.6 Deterioration of the overall wind environment	13
3.7 Comfort	14
4.0 Qualitative Wind Assessments and Quantitative Wind Studies	16
5.0 The basics of interaction between individual buildings and wind	17
5.1 General guidance for wind design	21
5.2 Site exposure	21
5.3 Rectangular towers and slab blocks	22
5.3.1 Downwash.....	22
5.3.2 The corner effect.....	25
5.3.3 Building setbacks	32
5.3.4 Wake effect	33
5.3.5 Arcades and colonnades.....	36
5.3.6 Pedestrian corridors and foyers	40
Practical advice.....	40
6.0 Interaction between groups of buildings and wind	41
6.1 Low bar buildings (“row” effect)	41
6.1.1 Practical advice.....	42
6.2 Low and high buildings in combination	43
Practical advice.....	43
6.3 Staggered buildings	44
6.3.1 Practical advice.....	45
6.4 Channel effect	46

6.4.1 Practical advice.....	46
6.5 Funnelling effect.....	46
6.5.1 Practical advice.....	47
6.6 Stepping effect	47
6.6.1 Practical advice.....	47
6.7 Courtyard effect	47
6.7.1 Practical advice.....	47
7.0 Architectural detailing design guidelines.....	49
7.1 Verandahs and canopies	49
7.2 Awareness of existing wind mitigation	49
8.0 Wind mitigation.....	50
8.1 Structures.....	50
8.1.1 Verandahs.....	50
8.1.2 Enclosed walkways	50
8.1.3 Roofing over the open spaces	50
8.1.4 Pedestrian corridors and foyers	50
8.2 Windbreaks	51
8.2.1 Independent windbreaks.....	51
8.2.2 Wind flows around windbreaks – protection factor	52
8.2.3 Windbreak protection factor: application to user discomfort.....	53
8.3 The functions of a windbreak	55
8.3.1 Vegetation	57
8.4 Cross-section shape of a windbreak.....	57
8.4.1 Practical advice.....	58
8.5 Dimensions of a windbreak	59
8.6 Permeability of a thin flat windbreak	61
8.6.1 Practicalities of the concept of porosity.....	63
8.7 Treatment of the ends of windbreaks	65
8.7.1 Practical advice for solid windbreaks	65
8.7.2 Practical advice for porous windbreaks.....	66
8.8 Examples of combinations of aerodynamic elements	68
8.8.1 Springboard with windbreak on top.....	68
8.9 Aerodynamic efficacy of planted windbreaks.....	69
8.9.1 Wooded strips (thickness about 20 m).....	70
8.9.2 Composition of the planted screen – practical aerodynamic advice.....	70
8.9.3 Implementation constraints	71

8.9.4 The composition of the soil (natural or added) and its water supply.....	73
8.10 Constraints and implementation of artificial screens	74
8.10.1 Practical Advice	74
9.0 Conclusion.....	76

1.0 Purpose of this Best Practice Guide

This guide explains how the wind rules and standards in the Wellington District Plan apply to new building developments. It also describes the simple wind engineering principles that relate to meeting the District Plans Wind Policies, in particular those relating to early consideration of wind in design in order to achieve the City's objectives of reducing the adverse impact of wind on public spaces. It therefore describes the features of a building that affect wind flows and the mitigation strategies that can be used to minimise adverse wind effects from a building development.

This guide is not intended to dictate how buildings should be designed. Rather, it outlines the basic wind effects caused by buildings and shows how particular features can cause or alleviate problems. The Quantitative Wind Study required under Wind Rule WIND-R1.4 (Section 88 information requirements and Appendix 8 WIND-A1) is intended to allow design freedom whilst requiring the submission of proof of the likely actual impact of a development, given its local context, rather than setting arbitrary height or building bulk rules. The guide is focused on avoiding problems through sound design of the building form. The goal is to avoid the late addition of aerodynamic devices such as verandahs to the design, because these devices are seldom as effective as good design of the building form itself.

The guide provides a brief introduction to wind and to the management of wind effects from proposed new buildings for planners, developers and building designers. It is not intended to replace the advice of wind specialists that is needed for environmental assessments of wind effects. 'Rules of thumb' are provided to help quantify the general wind effects of simple building forms. These are intended also to provide wind specialists with a consistent basis for providing a qualitative wind assessment under Wind Rule WIND-R1.4 (Section 88 information requirements and Appendix 8 WIND-A2).

2.0 Introduction

2.1 Wellington's wind climate/environment

Wellington is well-known for its windy environment. Strong wind gusts over 65km/hr are experienced in Wellington on average about 160 days a year, compared with 90 days in Invercargill, 70 in Paraparaumu, 60 in Christchurch or 50 in Auckland. The effects of Cook Strait and the hills around Wellington produce prevailing winds in the city which are either northerly or southerly. Northerlies are more frequent than the southerlies, but both can produce equally severe winds.

Wellington is significantly more windy than other international cities that have similar wind rules for urban development, such as London, San Francisco, Boston, and Toronto. The average wind speeds in London, for example are half those in Wellington. San Francisco experiences average wind speeds around 10% less than Wellington's lowest 6 month average, and are 50% less than Wellington's average over the whole year. Boston is the windiest of these cities and has an average for the year 25% lower than Wellington.

These wind speeds are measured 10m above the ground and therefore are twice the speed that would be experienced by a person standing on the ground. In the 1970s wind measurements established that wind speeds 10m above Wellington Airport are the same as wind speeds 150m above Wellington City, so in the City pedestrian level wind speeds will be less than a quarter the wind speeds reported at the airport. However, buildings can bring the upper level winds down to the street creating localised windy areas.

2.2 The basics of wind flow

In general, the wind speed increases with height in the first 150-500m above the earth's surface. The roughness or smoothness of the ground changes the rate of increase with height. At the same height above the ground, the average speed is greater at a site with low roughness (*Figure 2*) than at a site with higher roughness (*Figure 3*). Therefore, an aerodynamic anomaly such as a building, which is much taller than its surrounds, will produce higher wind speeds in open country than in a city. However, the likelihood of such anomalies is far greater in the city.



Figure 2 Flat open country - Low probability of aerodynamic "anomalies"

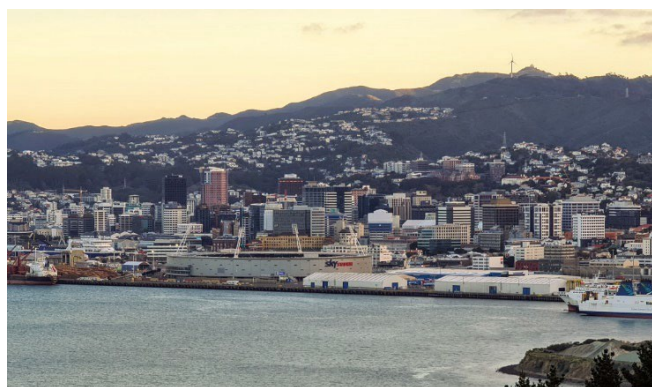

Figure 3 City centre has a high probability of aerodynamic "anomalies"

2.2.1 The built environment

Poor aerodynamic design of some buildings in Wellington has made the already strong prevailing wind conditions intolerable. These buildings have created street environments where walking can be not just uncomfortable but dangerous. The occasional publicity given to pedestrians being blown

over, or historical examples of ropes being placed along pavements for pedestrian safety (up to the 1980s, as shown in *Figure 4*), highlights the seriousness of the problem but does not reflect the extent of the problem.



Figure 4 A Safety Rope in Courtenay Place (Source: Evening Post Newspaper/28 August 1970/3679/10A-F. Alexander Turnbull Library, Wellington, New Zealand. <http://natlib.govt.nz/records/22736399>)

The adverse wind effects a building can create was highlighted in the 1920s with the introduction of the 30m tall Hope Gibbons building into Wellington’s otherwise rather low-rise 2-4 storey environment. Newspaper articles regularly reported personal injury to people, which resulted from their exposure to strong wind gusts induced by this building. For example, a Miss Clarke is reported in the Evening Post 14 March 1945 suffering “...a lacerated wound to the back of her head, [and] a fractured left thigh...” or a Mrs Woolf whose “...right wrist was broken, and she sustained bruises and abrasions and shock...” as reported in the Evening Post on 26 November 1936. Without the building, the winds were high. With the 30m high building (relatively small by modern standards) the wind became far stronger, gustier and more unpredictable.

Wind gusts exceeding 54km/hr have a significant effect on pedestrians. In wind tunnel tests women and children were removed from the testing regime for gusts over this speed. Gusts above 72 km/hr make wind conditions totally unsuitable for walking and cycling. Wind gusts up to 83 km/hr have been recorded in Wellington City streets.

It is not sufficient merely to prevent winds that could knock people to the ground or blow them into the path of vehicles. People also expect most outdoor areas to be liveable and enjoyable for most of the year. The aim is also to create environments that allow people to make the best possible use of their city, which includes both outdoor and indoor spaces. Parks and other areas used for sitting or relaxing, such as outdoor cafes, require wind conditions to be substantially better than ‘safe’.

~~Wellington City Council’s approach to development is stated in the District Plan’s Wind Chapter’s Objective WIND-O1: “The adverse impact of wind from new developments, additions and alterations on public spaces is managed to: 1. Provide comfortable conditions for pedestrians, whilst acknowledging that not all wind effects can be mitigated; 2. Ensure that new developments, additions and alterations do not generate unsafe wind conditions in public spaces and, where possible, ameliorate existing unsafe wind conditions; and 3. Prevent the gradual degradation of Wellington’s pedestrian wind environment over time.”~~

~~The District Plan has specific wind rules and standards that clarify how “the adverse impact of wind” are to be interpreted and controlled. Specifically this means:~~

- ~~1) that existing dangerous conditions are mitigated where possible (Standard WIND-S1);~~
- ~~2) that no new areas exceeding the danger criterion are created (Standard WIND-S1);~~
- ~~3) that the cumulative effect of new developments does not progressively degrade the pedestrian wind environment (Standard WIND-S2); and~~
- ~~4) that public spaces listed in the Appendix 9 of the District Plan have comfortable wind conditions (Standard WIND-S3).~~

2.3 Effects of building form on ground-level wind conditions/environment

Buildings that are exposed to wind induce changes in local ground-level winds, which can make activities such as sitting, strolling, shopping, or entering a building uncomfortable and even dangerous. In an open environment, where the building stands alone, the taller the building, the more wind is accelerated at pedestrian level. In an urban environment, the surrounding buildings have a huge effect on the exposure of a new development to wind. For this reason, general guidelines can risk either exaggerating or underestimating the effect of a proposed building. This is where Quantitative Wind Reports have great value: predicting the interactions of the urban form with the wind and with the development.

Building form and detailing can greatly affect wind-flow patterns and speeds. With an appreciation of how winds flow around buildings, designers can avoid creating high wind speeds at ground level. This is an especially important consideration for buildings that will be exposed to prevailing winds, and those near significant sites such as parks. The guidance in this document is based upon many systematic wind tunnel tests conducted at the CSTB wind tunnel facility in France in the 1970s. These identified the likely proportional increases in pedestrian wind speeds resulting from many different individual building forms, and the corresponding likely reductions in wind speed resulting from various building design features and street level wind breaks.

2.3.1 Considering wind early in the planning and design phase

Wind will need to be considered early in the planning and design of a development when the site is exposed or the building will be significantly higher than its surrounds, as the development is likely to impact the surrounding wind conditions. Internationally (*Figure 5*) and locally (*Figure 6*) it is possible to observe the effect of strong pedestrian-level winds on the financial and operational success of some new buildings.

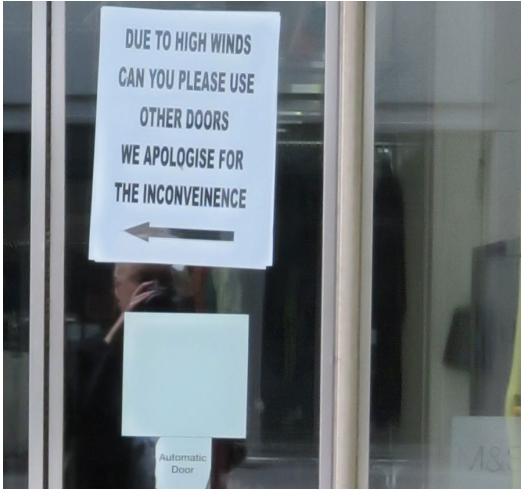

Figure 5 Sign on the door of the Marks and Spencer store opposite the notorious "Walkie Talkie" 40 storey building at 20 Fenchurch St, London

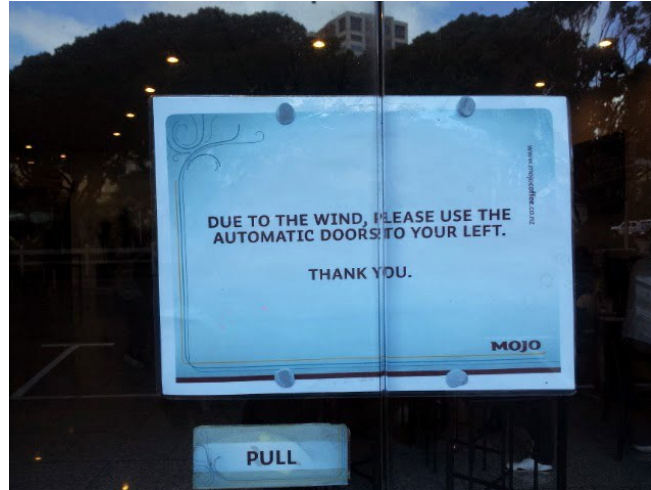

Figure 6 Sign on the door of Mojo cafe in the Asteron building in Wellington, displayed during northerly winds

For a resource consent application required through the Wind Chapter's rules, a Qualitative wind assessment (a desktop review based on expert opinion of a suitably qualified and experienced person) or a Quantitative wind report (detailed study based on wind tunnel testing or computer modelling) is required. The assessment or report is needed to fully understand complex wind flows generated by the development and the surrounding buildings.

The Qualitative assessment is less definitive and may therefore lead to more design changes than the Quantitative report, to provide sufficient confidence that the proposed design will comply with the Wind Standards. It is expected that a Qualitative wind assessment will be based on the best possible evidence of the existing wind conditions at the site, which might include using data from previous wind tunnel tests, or measured site data. The wind effects of the development should be estimated from the wind accelerations documented in this guide (refer section 5 to 8) for structures similar to the proposed design. The wind assessment will document how the design of the overall building form has dealt with possible problems. The addition of a verandah or a wind break is normally an insufficient response.

3.0 Wind controls in the District Plan

3.1 How the Wellington City District Plan wind controls work

Planning controls on the wind effects of new buildings and additions and alterations are set out in the Wind Chapter of the District Plan (under Part 2 District Wide Matters section of the Plan). To be consistent with the National Planning Standards, the wind provisions are included in a new standalone chapter, which sets out the previous wind requirements in a different format.

The technical requirements and reporting for wind effects have not changed significantly, but the thresholds where wind effects must be considered have been reduced slightly. Matters of discretion are now clearly listed in the wind rules, along with the information that must be provided.

Assessment criteria are listed for each wind standard to guide planners when a standard is breached. Best Practice Guidance has been updated for the new chapter.

The wind chapter of the District Plan contains objectives, policies, rules and standards and is supported by the Wind Chapter Best Practice Guidance (situated in Appendix 14 of the District Plan).

The Objective and Policies describe the high level outcomes relating to wind effects sought by the Council. They help interpretation of the Rules or Standards if there is uncertainty for resource consent planners when assessing a development application which triggers wind rules. They are also used by Wellington City if discretion needs to be applied to over-ride a Wind Standard. A standard may be over-ridden when other beneficial effects also accrue, or when the observed accelerations are in areas infrequently used by pedestrians but other areas around the same site that are high pedestrian use are made much better.

The rules and standards provide more detail than the objectives and policies, and are generally measurable.

The rules set out:

- the zones where the Wind rules and standards apply;
- the circumstances when a development is either a permitted activity or is restricted discretionary activity under the rule framework;
- the Wind standards that apply;
- the matters of discretion when the wind standards are not met; and
- the type of assessment and information that is needed as part of a resource consent application.

The Standards contain the most technical detail, including:

- what wind conditions are acceptable (i.e. evaluation criteria), covering the safety, comfort and the deterioration in wind conditions with a new development or addition or alteration; and
- assessment criteria that help to apply planning discretion when a standard is not met..

The safety and comfort criteria in the Wind Standard are based on criteria that are commonly used in many cities around the world. The safety standard applies to all the zones where the Wind Rules apply, while the comfort standard only applies to significant parks and recreational spaces that are specified in the District Plan. Elsewhere, comfort is controlled, in part, by the general deterioration standards, which limit the gradual worsening of wind conditions in an area as a series of developments occur.

The general deterioration standards apply to all parts of Wellington where the Wind Rules apply and are intended to reduce the likelihood that several developments over time worsen the wind to the point where the street has wind conditions that are unpleasant or dangerous.

3.2 Triggers for wind controls

Wind effects created by a development only need to be assessed against the Wind Rules and Standards when a development exceeds the thresholds listed below, which trigger the requirement for a wind assessment or wind study to be provided to the Council. The trigger point does not correspond to when wind effects start to occur, but is simply a practical threshold when the wind effects will usually be significant enough to warrant investigation.

~~City Centre Zone, Metropolitan Centre Zone, Special Purpose Port Zone, Special Purpose Port Zone and Special Purpose Waterfront Zone trigger:~~

- ~~• when building height is greater than 20 metres; or~~
- ~~• when an addition is greater than 8 metres in height; or~~
- ~~• when a rooftop addition is more than 33% of the existing building volume and is setback from all sides adjacent to public spaces by at least 5 metres.~~

~~Local Centre Zone, Neighbourhood Centre Zone, Special Purpose Hospital Zone and Special Purpose Tertiary Education Zone trigger:~~

- ~~• when building height is greater than 12 metres; or~~
- ~~• when an addition is greater than 4 metres in height; or~~
- ~~• when a rooftop addition is more than 33% of the existing building volume and is setback from all sides adjacent to public spaces by at least 3 metres.~~

These thresholds correspond to buildings that generally produce significant changes in the surrounding wind conditions. The City Centre Zone etc. thresholds are larger than the Local Centre Zone, Neighbourhood Centre Zone, Special Purpose Hospital Zone and Special Purpose Tertiary Education Zone thresholds because the other larger buildings in the City Centre Zone etc. typically provide greater shelter to smaller nearby buildings. However, these triggers are a crude approximation of the wind effects at specific sites or from specific buildings, so the Wind Rules allow for some discretion and relaxation of the reporting requirements if a site is exceptionally sheltered or a building design is expected to have an exceptionally low impact on wind conditions. ~~In these situations, a Qualitative wind assessment (i.e. wind expert opinion) may be accepted in lieu of a Quantitative wind study.~~

~~For the City Centre Zone, Metropolitan Centre Zone, Special Purpose Port Zone, Special Purpose Stadium Zone, and Special Purpose Waterfront Zone, a quantitative wind study will usually be required to show compliance with the wind standards. Council may accept a qualitative wind assessment when a development is likely to have little, if any, impact on wind conditions.~~

~~For the Local Centre Zone, Neighbourhood Centre Zone, Special Purpose Hospital Zone, and Special Purpose Tertiary Education Zone, a qualitative wind assessment is usually all that is required to show compliance with the wind standards. However, if a development is assessed to have a large negative impact on wind conditions, then a quantitative wind study may be required to enable the wind effects of the development to be fully understood.~~

~~It is up to the discretion of the resource consent planner to decide whether a quantitative wind study or a qualitative wind assessment is required.~~ The requirements for quantitative wind studies and qualitative wind assessments are also set out in Appendix 8 of the District Plan.

Examples of buildings that have a negligible effect on pedestrian-level wind conditions, where a desktop assessment should be accepted include:

- a building or addition that is consistent with other building heights in the neighbourhood and is sheltered from all prevailing winds by adjacent upwind buildings;
- an addition that is small in scale compared to the existing building, and incorporates wind mitigation measures such as verandahs, setbacks and breezeways;
- an alteration that is a minor rooftop addition (e.g. Lift or ventilation room) which is setback from all sides of the existing building;
- a structure that does not impede wind flows, e.g., aerials and masts; and
- a building or addition that is consistent with other building heights in the neighbourhood and is separated from all pedestrian areas by adjacent buildings.

3.3 Building configurations

The Wind Standards require the wind conditions around a development to be compared to the existing wind conditions, which means both the existing site configuration and the proposed building configuration will need to be tested and evaluated. This requirement applies to both the Qualitative and the Quantitative wind assessments.

When a development does not comply with the Wind Standards, further testing and evaluation of alternative configurations is required to show that the best practical design for wind has been developed. The design changes that may be needed for wind will depend on the degree to which the Wind Standard is breached and the severity of the wind effects.

Quantitative wind reports and Qualitative wind assessments need to address the relative impact of different building forms on the pedestrian wind environment and any ameliorative additions that are added to the basic building design. For example, acceleration of the wind in the street may be due to wind channelled along the street in a different manner than the existing flow, and be similar whether the building is 20 storeys or 2 storeys in height. In this circumstance, the wind assessment should focus on ensuring pedestrians have safe and comfortable routes past the areas experiencing accelerated winds. But, if the height of the building is the cause of the accelerated winds then the assessment should address the effects of the height of the building.

One notorious submission to Wellington City Council as part of a proposed development stated that the proposed building would have “no worse effect than any other building of a similar bulk”. This submission missed the point of a wind assessment, which is to find the best practical design. To mitigate the acceleration of the wind at pedestrian level, it is likely that the “sail area” that the building presents to the wind would have to be reduced. This guidance not only outlines the potential accelerations of various building and urban configurations, but it also suggests possible improvements that can be achieved through alternative building forms.

The goal of the District Plan is to encourage good design for wind, rather than rely on ‘tack-on’ wind shelter such as freestanding walls or canopies that is needed to mitigate strong winds created by poor wind design.

Sections 5 to 8 of this guide outline design features and wind mitigation that can be used to avoid windy conditions.

3.4 Application of discretion in assessment of wind impacts

Wind conditions around a development need to be considered in light of the expected use of individual locations and areas, as different areas do not necessarily have equal importance to pedestrians. Areas that are heavily used (e.g. entrance ways to buildings, bus stops) or that have high amenity (e.g. outdoor café seating) should be more heavily weighted for benign wind conditions compared to areas that are infrequently used or have little amenity value (e.g. carparks and arterial roads)

Non-complying wind conditions, particularly winds that exceed the safety limits, require careful investigation and mitigation. If increases in gust speeds are balanced by decreases in gust speeds elsewhere, then the assessment of these changes needs to consider both the relative areas that are affected and the pedestrian use/amenity of the respective areas. It is entirely feasible that the wind issues have not worsened overall, but rather they have been moved in position in the street. Designated parks as well as key pedestrian routes through the city are prioritised with regards to ensuring good wind conditions. Therefore, careful consideration is needed, beyond a simple averaging of the wind speed changes across the site, to balance the competing benefits and disadvantages of wind flows that are redistributed by a development.

3.5 Safety

No matter how windy a site is, pedestrian safety is fundamental to the design of new buildings. A development should be designed to minimise the likelihood of danger to pedestrians, and at a minimum, not worsen dangerous wind speeds at street level.

The safety standard for Wellington requires the annual maximum 3-second gust wind speed to not exceed 20 metres/second (72 km/hr) at pedestrian level. The annual maximum 3-second gust corresponds to the highest wind speed that is expected to occur during the windiest hour for each wind direction during the year. The gust is therefore relatively infrequent, but it is indicative of many more, slightly lower, wind gusts that will also occur at other windy periods throughout the year.

Wellington's windy climate, and urban form means that wind conditions in some areas of the city currently exceed safety limits in the District Plan. While high wind speeds are unavoidable in many circumstances, the Wind Rules are written to encourage new buildings to improve existing wind conditions that are dangerous.

3.6 Deterioration of the overall wind environment

Significant changes in wind conditions can gradually occur over time from the cumulative effects of new developments in an area. A gradual deterioration in wind conditions from subsequent development is limited by the Deterioration of the wind environment criteria in the Wind Standard WIND-S2. These criteria limit the allowable deterioration in wind conditions that can occur at individual locations around the development (recognising that some localised change is almost inevitable), and also specify the net change, averaged over the whole area, to be zero. Overall, a neutral or beneficial effect on wind conditions is sought.

This overall deterioration of the wind conditions is measured by the changes in the number of hours that the mean wind speed equals or exceeds 2.5 m/s. This mean wind speed is used in many cities to categorise the suitability of wind conditions for people wanting to sit or relax for long periods.

The criterion for the overall deterioration requires the change in hours per year to be averaged across all of the areas that are affected by a development. To do this, wind speeds must be measured sufficiently far from a development to pick up all the wind speeds changes that occur, and

the averaging of the changes must account of the area that is represented by each measurement. For example, taking 10 measurements at one end of a street, and only 2 at the other end, will not give a good estimate of the extent of changes, nor will the average measured change be representative of the net effect. The Quantitative and Qualitative wind assessments should provide commentary that specifically addresses the overall effect of a development, noting the high pedestrian priority areas, and how representative the averaging process is of specific areas close to and far from the new development. For example, if the area near the building is significantly affected, but the overall effect, taking account of the many other measurement points not affected, then the wind report needs to address this.

3.7 Comfort

The Comfort Standard WIND-S3 limits the amount of time during the year that mean wind speeds of 2.5 metres per second, or more, are experienced within an area, to no more than 20 percent of the time (this equates to 1752, or more, hours per year). This standard only applies to specific parks (these are listed in the District Plan [in Appendix 9](#)). In other parts of Wellington, the wind standard covering the Deterioration of the Wind Environment (WIND-S2) will also be used to maintain comfortable wind conditions where they currently exist.

Wind speed is only one of the factors that affect people's comfort outdoors. On windy days comfort also depends on:

- gustiness (variation) of the wind – notably peak wind gusts;
- the climate and the season;
- the temperature, precipitation, sunlight, shade and humidity;
- what people are doing;
- what people are wearing; and
- the age and psychological state of the individual.

The above factors are beyond the scope of the wind controls in the District Plan and this guide, which defines comfort only in terms of wind speeds. However, these factors have been incorporated into more complex outdoor comfort indices, which are briefly outlined below.

In the 1990s a series of research efforts looked to develop a heat balance model which included all basic thermoregulatory processes, such as physiological sweat rate, enabling the user to predict real values of thermal qualities of the body (Hoppe, 1993; Hoppe, 1999). This work has resulted in the publication of two outdoor thermal comfort indices.

The first is “Physiological Equivalent Temperature (PET)” (VDI, 1998; Hoppe, 1999; Matzarakis 1999). It is based on the “Munich Energy balance Model for Individuals” (MEMI) (Hoppe, 1993). In 2012, the International Society on Biometeorology (ISB) developed the Universal Thermal Climate Index (UTCI) based on a multi-node model of thermoregulation which is thermo-physiologically responsive to all models of heat exchange between body and environment (Jendritzky, 2002).

In 2021, Kasun Perera at the Victoria University of Wellington School of Architecture, published his analysis of over 1100 surveys of thermal comfort of people outdoors. He demonstrated that the laboratory-based PET and UTCI theoretical indices have limited practical application. They predict most people surveyed should be comfortable, which is no surprise as they had elected to sit outside when approached during the survey. Unsurprisingly, responses were different for different seasons

and when people had differing expectations of how they planned to use the public space. Perera's Combined Adaptive Factor enables a more holistic comfort standard to be applied to parks.

In Sections 5 to 8, a person's wind comfort is assessed by the percentage increase in wind speed around a building (compared to no building), which corresponds to an increase in their discomfort. Throughout this guide the percentage increase in wind speed is referred to as a percentage increase in discomfort.

Two particular phenomena are not directly included in this measure of discomfort:

- the direction of the flow relative to pedestrians which has an especially critical effect when the flow is ascending (the "reversed umbrella" effect); and
- rapid changes in wind speed which have a significant effect on pedestrian discomfort, especially if the person is moving (such as stepping around the corner of a building from an area of low, to an area of very high speeds in perhaps two paces).



4.0 Qualitative Wind Assessments and Quantitative Wind Studies

A Qualitative Wind Assessment is a desktop review of the effects a building will have on the wind environment, which is based on expert opinion. A Quantitative Wind Report differs from a Qualitative Wind Assessment in that it is based on detailed wind tunnel testing or computer modelling to determine the specific wind conditions at a site and wind effects of a development. The rules or thumb contained in sections 5 to 8 will be most useful for Qualitative Wind Assessments, where site specific or building specific data is not available. When site specific or building specific information is required, then a Quantitative Wind Study will need to be undertaken.

The material in the following sections of this guide describe in general terms the wind interaction of individual building forms with idealised urban forms created by groupings of buildings, and of wind shelter features such as windbreaks. These sections provide general design information on their wind effects in urban spaces. In addition, the information is intended to help designers identify options that could be explored should a Quantitative Wind Study need to identify non-compliant wind conditions in public spaces.

If these design options have not been incorporated into the preliminary design, it is anticipated that the options will be analysed if they are likely to improve the performance of a design. Equally, Council officers can use this information to assess whether all practical measures have been taken to avoid worsening the wind in the city.

For example, if it appears likely from a Quantitative Wind Study that the design of a proposed building is causing accelerations at street level, the study should investigate whether the issue is, say, due to downwash from a tall façade or channelling between buildings. If the height of the façade is the issue, a shorter building should be tested to determine the degree of the wind acceleration due to façade height. Alternatively, if horizontal channelling is the issue, then design options should be investigated which reduce this channelling effect without placing vertical windbreak screens in public spaces.

The role of the following sections in a Qualitative Wind Assessment is far more systematic than for the Quantitative Wind Study. It is expected that a specialist completing an Assessment will quantify the wind effects using the guidance in these sections the standard design situation that most closely resembles the proposed design.

As often as possible the baseline wind speeds estimated in a Qualitative Wind Assessment for an existing site should be based on measurements made at the site, or on the results of previous Quantitative Wind Studies that have been recently completed nearby. The wind accelerations for the proposed design should be derived from the documented accelerations of the closest building form or urban configuration in Sections 5 through 7. Mitigation measures should in turn be based on the practical advice for those building forms in these Sections.

In principle, the goal is to avoid wind accelerations at pedestrian level that require tack-on features that are not part of the basic design, such as free-standing windbreak screens. Where such measures are proposed, their effectiveness should be estimated from the data in Section 8.

5.0 The basics of interaction between individual buildings and wind

Buildings form obstacles to wind flows, causing a positive pressure zone to be formed on the windward face. At the same time, a negative pressure (which forms a suction) zone is created at the sides of the building. An increase in wind velocity occurs where the two zones meet, and the wind flows from the positive to the negative.

Pedestrian-level winds result from a complex reaction between the wind and the building(s), involving the building's shape, size and relationship with other buildings. Different-shaped buildings generate different wind effects.

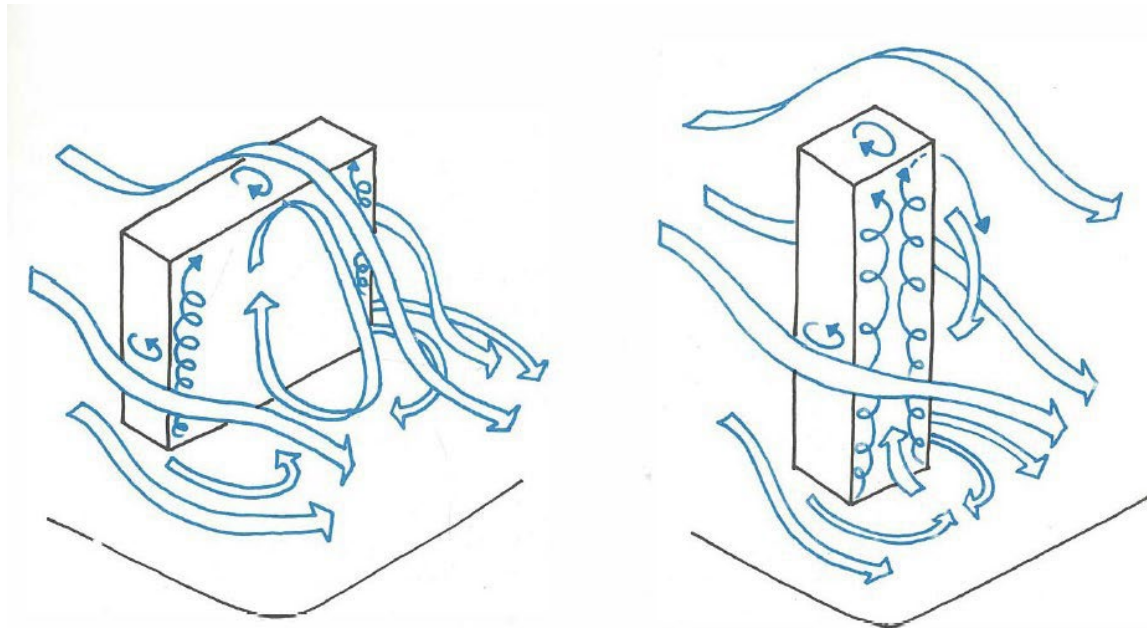

Figure 7 Wind flow around buildings of different geometries.

The best approach to the problem of unpleasant pedestrian wind conditions lies in the placement and design of buildings. Buildings should not be allowed to be designed without regard for their surroundings, and tall slab-sided buildings should not be built in isolation. Attention should be given to the entrances and immediate forecourt area of buildings.

One building placed to windward of another can act as a wind shield, protecting the second building. A tower block rising out of a podium, a building with substantial verandahs around it just above pedestrian height, a building which has vents through it in non-pedestrian areas to channel wind, or a building which is circular or octagonal in shape generates fewer undesirable wind effects. However, even with such designs, it cannot be assumed that further wind analysis is unnecessary, since variations of building design or the immediate environment may combine to worsen wind conditions.

It is very difficult to predict accurately the interaction between the complex, turbulent natural wind flow and a single sharp-edged three-dimensional object like a building. The matter is made immensely more difficult when the building is surrounded by many other buildings that are typically nearby in an urban environment. Currently, the only way to predict a building's wind environment reliably is by way of a Quantitative Wind Study. While computational fluid dynamics (CFD) can be used to indicate the changes in average wind speeds around buildings, there is little evidence that it can yet reliably predict the local turbulence and thus be used to predict wind gusts that indicate

safety issues. Since either approach is costly, the developer is often in a dilemma, undecided whether to:

- undertake a full wind tunnel test before preparing working drawings, and risk having the wind tunnel report invalidated by subsequent design changes; or
- undertake the full wind tunnel test after the preparation of working drawings, and risk the report necessitating major changes to the working drawings.

Sound aerodynamic design early on can avoid the need for time consuming and expensive major revisions.

The following paragraphs summarise the likely effects of isolated buildings of simple basic forms on the ground-level wind environment in their vicinity. The diagrams and the discomfort levels, which are theoretical case studies undertaken overseas, are accurate only for the building configurations shown. In complex urban situations it is much more difficult to predict the wind effects of a new building. This makes expert advice essential.

In general, the larger the mass of a building (especially the height), the greater the disturbance to the pattern of wind flow.

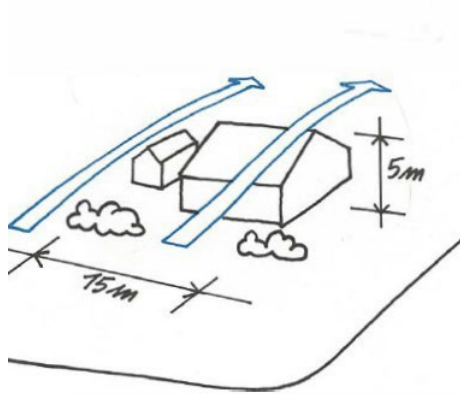

Figure 8 The wind flows over the obstacle without being deflected significantly

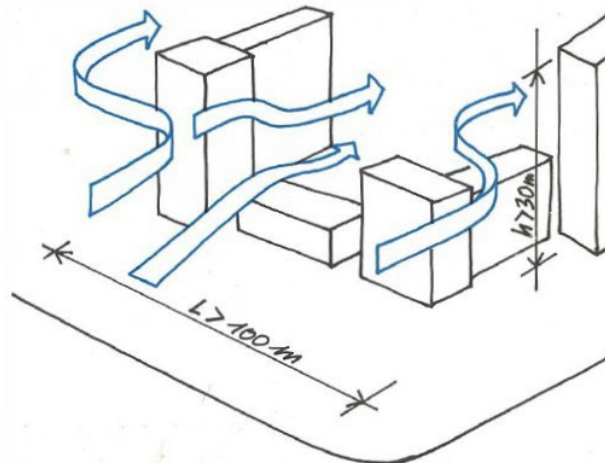

Figure 9 The wind is very strongly deflected and strongly altered by the set of buildings

The wind varies over time, thus, even stationary, a person experiencing wind gusts will be subjected to a wind forces that vary in intensity and direction over time.

This unstable effect constantly forces pedestrians to adapt to a new state and causes the main discomfort for walking and balance, hair styling, the agitation of clothes, the use of umbrellas etc. The level of turbulence in the wind characterises the variability over time.

Consequently, for the comfort criterion in this guide, as well as for the procedures that result from it, we only take into account the discomfort due to the “wind phenomenon”. This is then characterized locally by the average speed and turbulence. Other aspects such as ambient temperature, the psychology of the individual, etc., are not taken into account in this criterion.

It should be recognised that old urban forms, by their high density and similar building heights, create relatively sheltered environments.



Figure 10: The wind does not penetrate into densely packed buildings

Aerodynamic 'anomalies' in an old urban environment are unlikely, except at the foot of tall buildings that emerging above the neighbouring buildings. For example, a 100m tower in an old urban form will cause generate adverse winds at ground level. The diagram below shows significant discomfort will be experienced in the immediate vicinity at the base of the tower (strip of the order of 10 m wide), where the wind is accelerated by 60%.

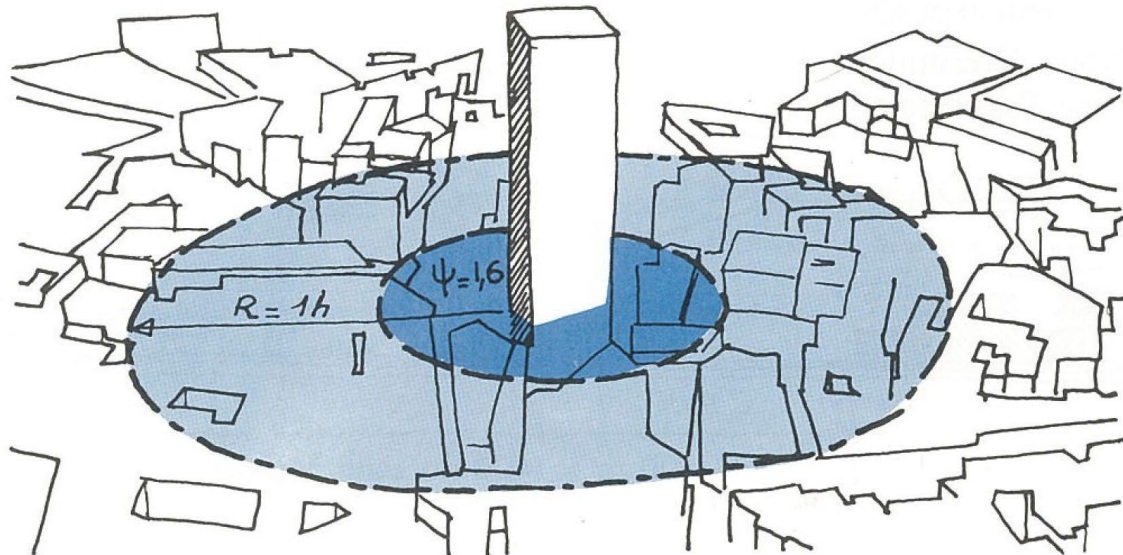

Figure 11: Area at base of a building where discomfort will be experienced by people

Adverse wind effects from a tall building (47 floors, 169m tall) in a relatively open urban environment was reported in Manchester in 2014 (refer <https://www.manchestereveningnews.co.uk/news/greater-manchester-news/gallery/wind-manchester-blows-people-over-6702867>). The tall building and its effect on people in the surrounding streets is shown in the photographs below. The average wind speed in Manchester is roughly half that in Wellington.



5.1 General guidance for wind design

The following guidance is based on studies of the interactions of idealised buildings and the wind.

Buildings will induce high wind speeds at ground-level if a significant part (that is, one-third the building's height or more) is clearly above the height of buildings located upwind.

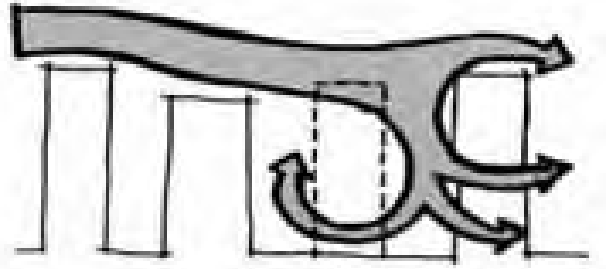

Where a new building is planned the design should consider:

- the wind environment created by the surrounding buildings;
- the impact the new building will have on the existing wind patterns; and
- the impact the new building will have on the balance of the site.

Where there is a likelihood that re-development of adjoining sites or sites within the localised wind environment may occur, designers should consider the potential changes to the wind patterns effecting the new building, and make the design as robust as possible in relation to pedestrian safety and comfort.

5.2 Site exposure

A building of similar height to its neighbours may be protected from large wind loads and cause minimal pedestrian level wind discomfort. However, this situation is lost when either:

- a building is introduced that is significantly taller than its neighbours; or
- a compatibly-sized building is demolished, and replaced by either a relatively low building or an open space. The degree of increase in discomfort depends upon the scale of the open space created.

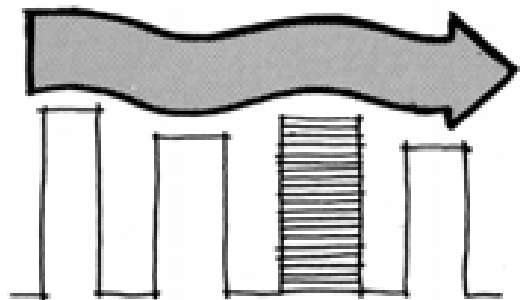

The sites where simple form buildings have the greatest potential for creating adverse wind conditions are those in areas with drastic variations in building height. The greater the area of the windward face exposed to wind, the greater the potential problem, because of the absence of shelter from upwind buildings.

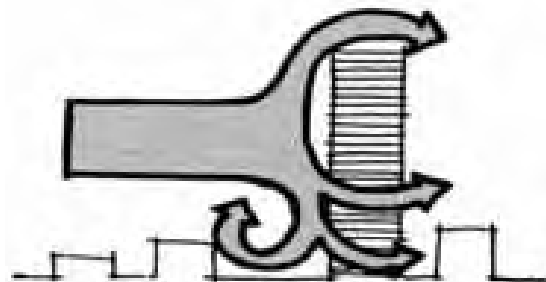

A cluster of buildings of similar height will tend to shelter pedestrians within the cluster.

5.3 Rectangular towers and slab blocks

Because the wind speed typically increases with height, the top of a tower is exposed to wind speeds and pressures that are higher than at its base. The higher pressures at the top of a rectangular building force the air to flow down its windward face, so increasing wind speeds at pedestrian level.

5.3.1 Downwash

The taller a building, the greater the pressure difference down the windward face of the building due to the wind speed increasing with height. This leads to a flow of wind down the face of the building driven by this pressure difference. This phenomenon is known as downwash. The height of the building must be greater than 15m for a noticeable effect.

A simple rectangular building will likely have a zone of increased wind speed at the base of its windward face, due to downwash.

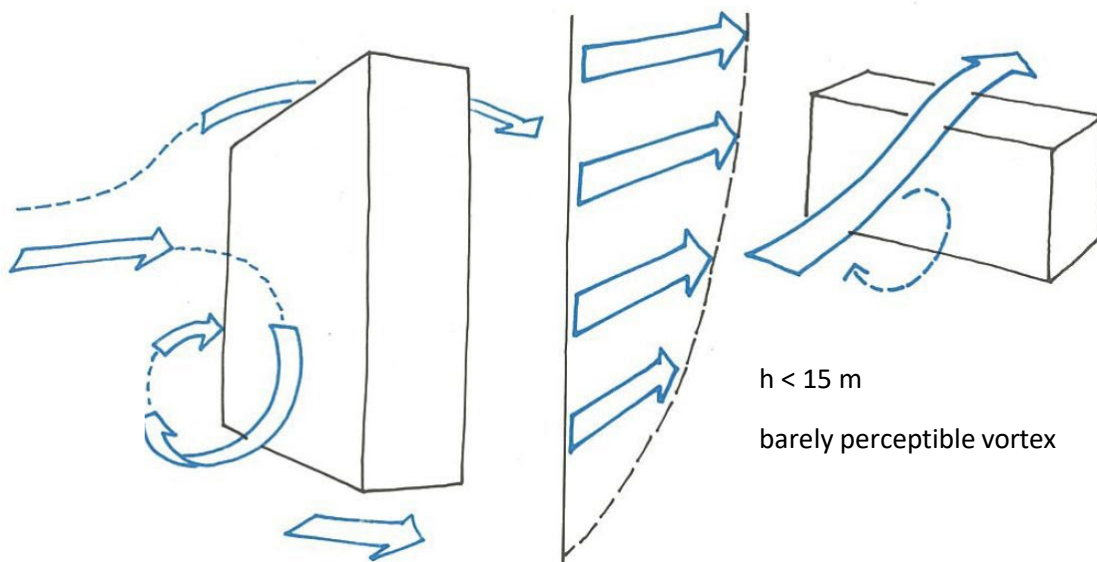
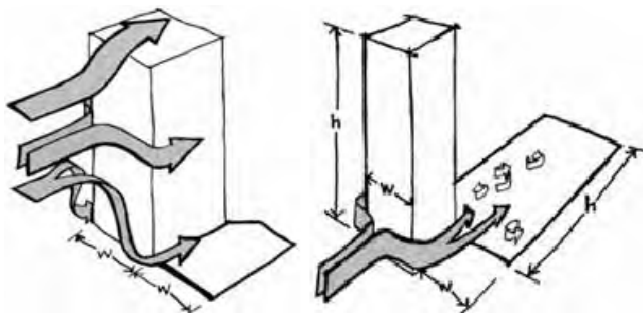

Figure 8 The wind flow mostly crosses over the top of the building where $h < 15m$

For wind incident at right angles to a 60m high rectangular building, the acceleration at the base of a building is over 50%. This disturbance is particularly unpleasant because of the vertical component that the flow in the vortex can have.



The deflected wind flow has the following properties:

- 1) A vortex of reversed wind flow in the centre front of the building;
- 2) Swirling accelerations up to the width of the building either side; and
- 3) Swirling winds in the wake for a distance downwind equal to the height of the building.

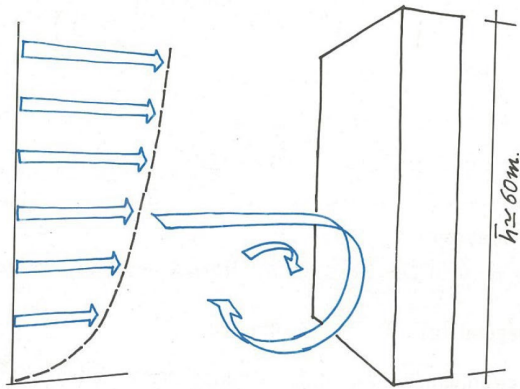

Figure 13: Vortices created at the base of a 60m high building

5.3.1.1 Practical advice

<p>Densify the nearby environment. Introduce deflector awnings / 'verandahs'.</p>	<p>Introduce porosity into the building above the pedestrian level.</p>



Figure 9 Even with extensive verandahs and a porous façade for the two storey car parking levels above the first floor, the sheer bulk of this building causes significant deterioration in wind conditions on the adjacent footpaths. Featherstone Street, Wellington



Figure 10 Two buildings with porous facades at car parking levels and with pedestrian level verandahs. Lambton Quay, Wellington



Figure 16 Aurora House, The Terrace, Wellington. This building has chamfered corners to reduce the width of the building 'catching' the wind; combined with a large glazed verandah



Figure 17 Scale of the space provided by the verandah in Figure 16



Figure 11 Clustered lower buildings nearby have reduced the need for the chamfered corners as they have achieved something closer to situation pictured in Figure 21, The Terrace, Wellington

5.3.2 The corner effect

The worst area where downwash is experienced is at the windward corners of a building. From a wind point of view, therefore, the worst place for a building entrance is on a corner that is exposed to the wind.

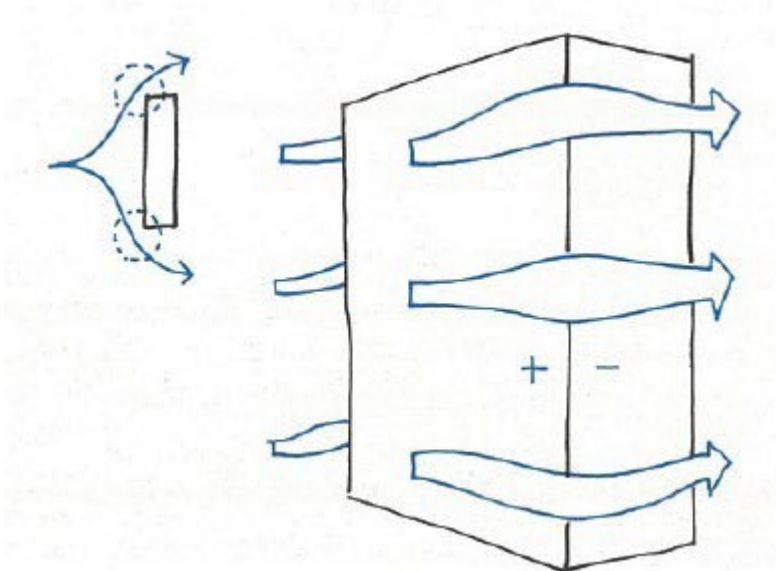

The increase in discomfort levels due to the corner effect can be similar to the range experienced from the downwash effect.

Near the windward corners of a wide low-aspect ratio building the following accelerations are typical (the effect varies with building height),

- a 4-storey building will cause a 20 percent increase in discomfort level
- a 10-storey building, a 50 percent increase

$$\bar{h} = 15\text{m} \rightarrow \psi \approx 1,2$$

$$\bar{h} = 35\text{m} \rightarrow \psi \approx 1,5$$

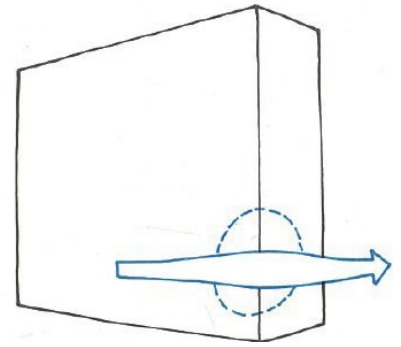

Near the windward corners of a narrow high-aspect ratio building the following accelerations are typical (the effect varies with building height),

- a 15 storey building, a 40 percent increase
- a 35-storey building, a 120 percent increase.

$$\bar{h} = 45\text{m} \rightarrow \psi \approx 1,4$$

$$\bar{h} = 100\text{m} \rightarrow \psi \approx 2,2$$

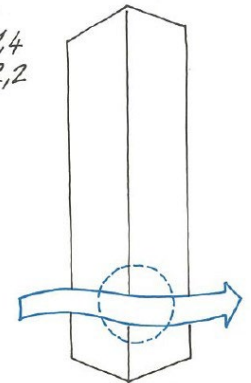

The air concentrated at the base of the windward face of a building flows rapidly from there around the windward corners of the building towards its more sheltered sides and rear. What makes the corner effect worse from a pedestrian point of view is that the transition zone between high- and low-speed winds at these corners is small. Pedestrians crossing this zone encounter, unexpectedly and hence in a potentially dangerous way, sudden changes in wind speed. The greatest wind speeds are generated within a distance equal to the width of the building face.

The following practical advice should be used in early design to avoid the potential problems, and should form the basis for the alternatives assessed in the Quantitative Wind Studies and Qualitative Wind Assessments.

5.3.2.1 Practical advice :

Surround the volume with a ground floor element.

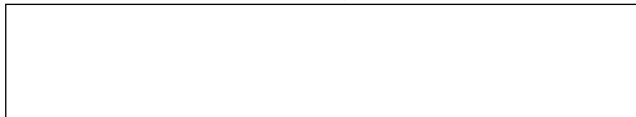
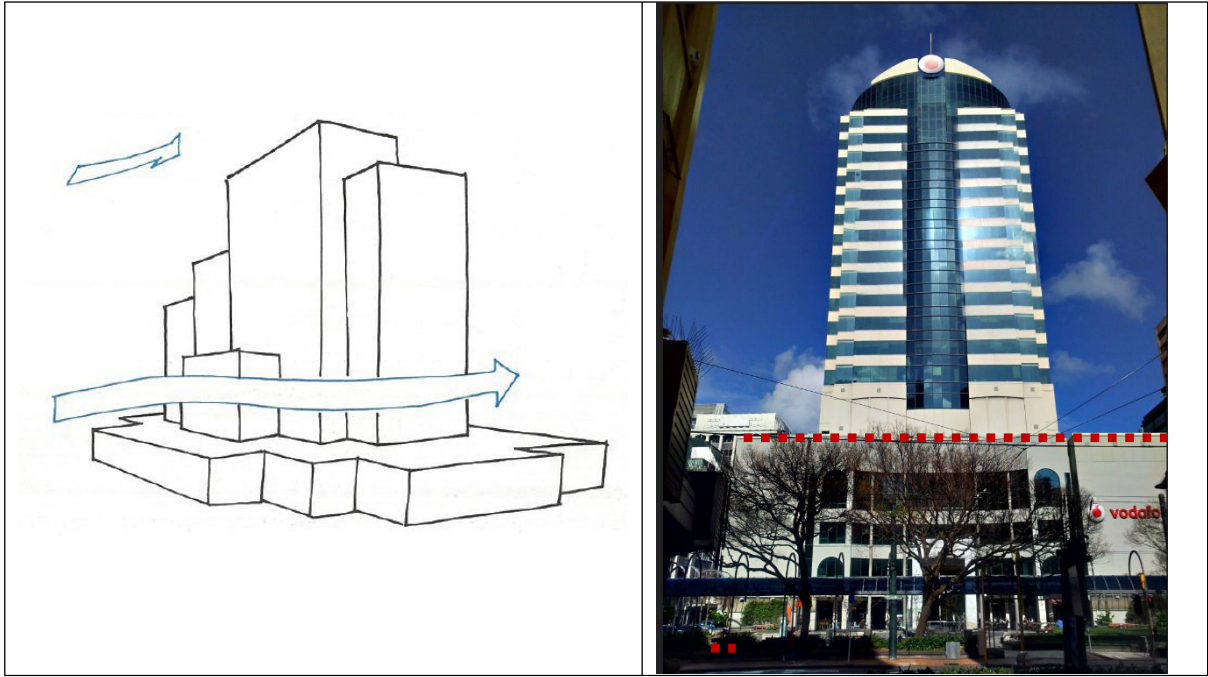
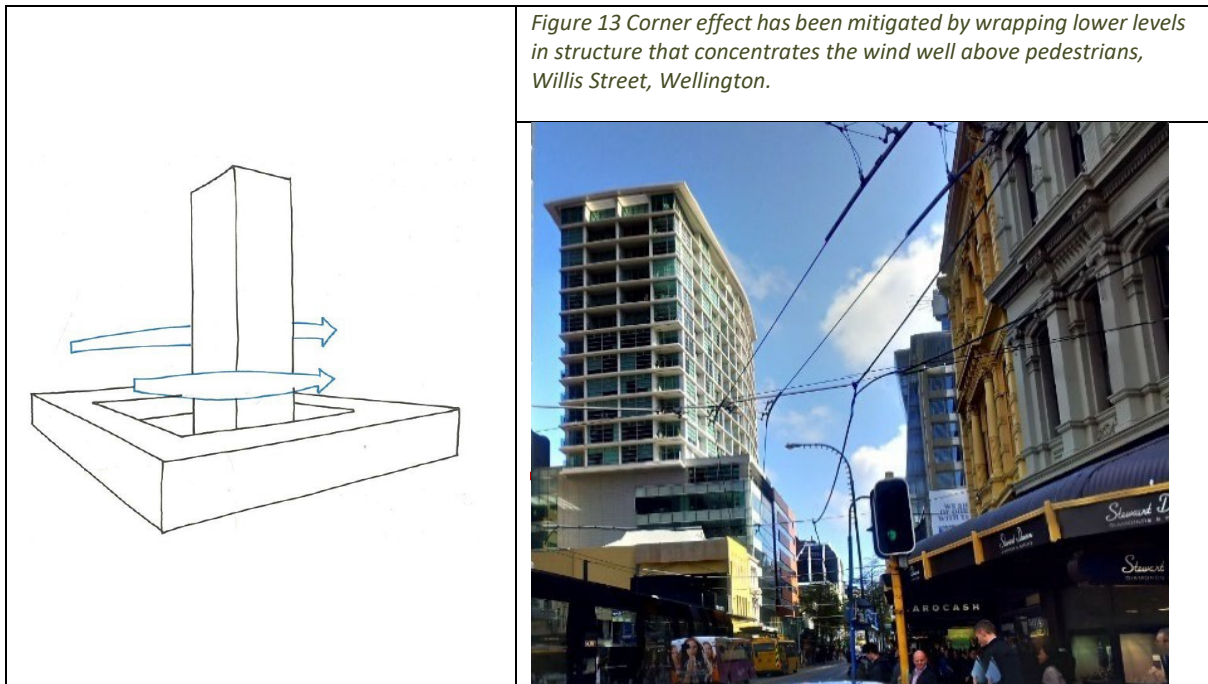

Figure 12 Corner effect mitigated by wrapping lower levels in structure that concentrates the downwash wind well above pedestrians. Wellington.



Surround the tall element with other buildings such as multi-level obstructions.



Gradually reduce the height.

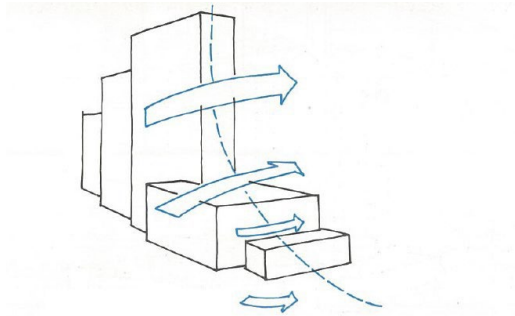

Figure 21 Wind flow is diverted "sideways and up"



Figure 22 The combination of buildings provides the sort of wind diversion illustrated in Figure 21; Manners St, Wellington

Rounded corners decrease downwash

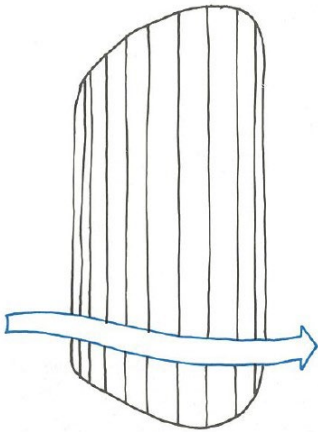

Figure 14 Corner effects of an isolated building are mitigated by 'cloud' plan shape, Bowen Street, Wellington



Figure 15 Corner effects of an isolated building are mitigated by the rounded planform, Boulcott Street, Wellington

Provide porous elements close to the corners.

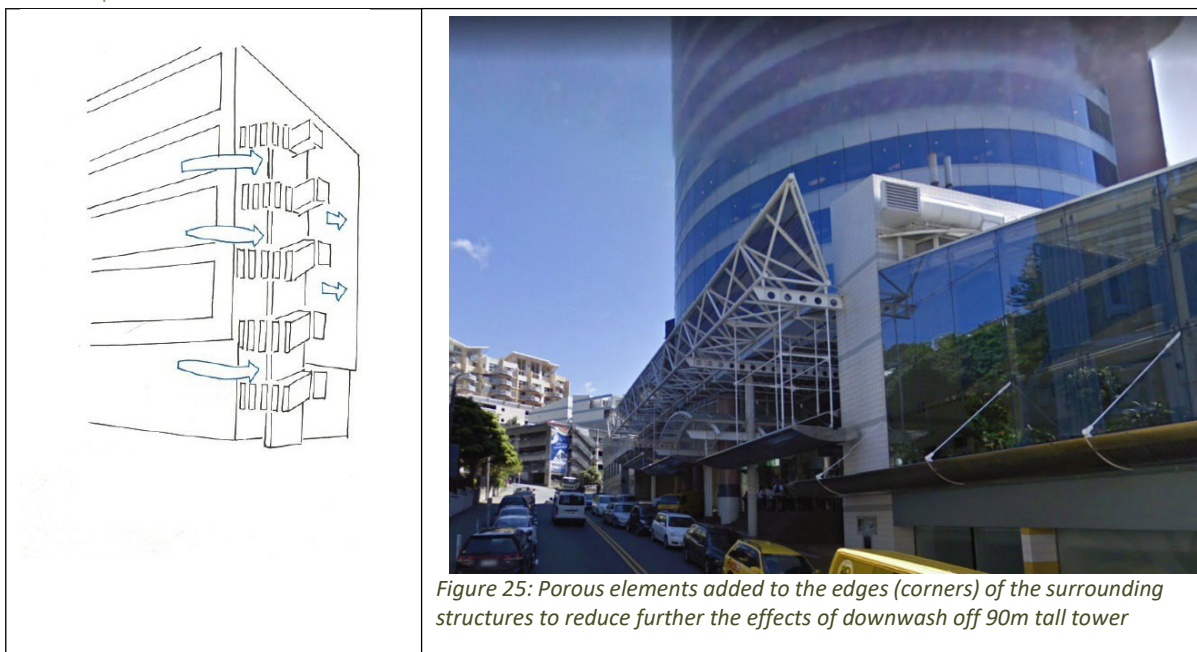

Figure 25: Porous elements added to the edges (corners) of the surrounding structures to reduce further the effects of downwash off 90m tall tower

5.3.2.2 Combining good building design features.

When many of the wind design measures were brought together in the 1980s and used in a building 40m high (Figure 26), it caused far less wind issues than the ~30m high Hope Gibbons building that caused many wind problems from the 1920s until the 1980s. Features include: chamfered corners, which function very much like rounded corners; an open car park level above pedestrians to allow the downwash to dissipate through the building; and an extensive verandah as close to pedestrians as possible.



Figure 16 Chamfered corners of the tower reduce the impact on the wind of a broad flat wall, and are simpler to build than a curved planform; also open first floor car parking diverts wind flow above pedestrians. Victoria St, Wellington

5.3.2.3 Landscaping (vegetation, or low construction) at the corners.

It is common to assume that placing trees as porous elements will reduce the “corner effect”. It is assumed their porosity will smooth the wind flow and the planting will have the added benefit of

moving pedestrians away from the corner. However, there are many practical problems with reliance on planting. These include:

- maintenance (who is responsible in the long term);
- design of the city urban landscape;
- blocking or restricting pedestrian pathways and access; and
- the practicalities of growing trees in windy environment.

Damping of wind flows by vegetation

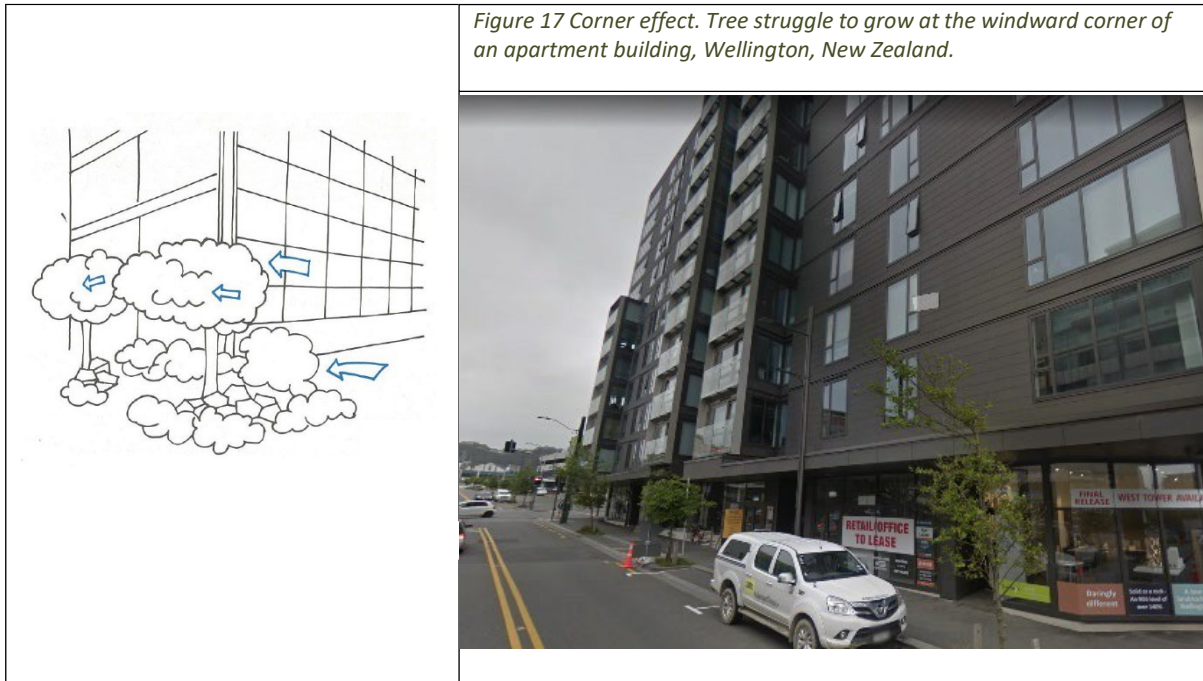

Another issue that can arise in the planning and development process is miscommunication and misunderstanding between the many disciplines that are inevitably involved in the design of large complex urban buildings. At times, the landscaping that is wind tunnel tested is not what is planted. A landscape architect may have plants installed that will withstand the wind, but they may not provide the shelter required. A relatively tall building London, at 20 Fenchurch Street – the so-called ‘Walkie-Talkie’ building, demonstrates this problem of reality not matching what was tested. Wind tunnel tests showed a continuous row of trees 10m tall, underplanted by other screening shrubs of at least 1m height, would resolve predicted dangerous winds on the corner illustrated in *Figure 28* was. The reality of the trees and planting, illustrated in 2016, has no significant wind mitigation effect whatsoever.



Figure 18 Corner effect. "Walkie Talkie" building, 20 Fenchurch St, London. Proposed trees in a continuous row 10m tall, recommended by wind tunnel testing to reduce dangerous winds at this corner, were never planted. The trees are too far apart and not underplanted as recommended

It is also worth noting that wind conditions around the 20 Fenchurch Street deteriorated for another reason. This was due to a misunderstanding of the way the wind tunnel test results had been written. Wind conditions had previously been suitable for quiet wanders and window shopping but were initially predicted to deteriorate to dangerous winds at the corners. The wind tunnel testing suggested the 10m-tall, planted screen would solve this problem. However, the solution only avoided the dangerous winds. The street was still, with the suggested planting, predicted to be much windier than it had been previously.

This example illustrates how important it is for plans that are submitted for planning approval are compatible with the results of the wind tunnel tests and assessments. If planting is recommended as wind mitigation in a Quantitative Wind Study or a Qualitative Wind Assessment, then planting of the scale, density and hardiness required should be included not only in the architectural plans, but also in the landscape proposals.

5.3.3 Building setbacks

Setbacks of the ground floor around a building may improve the pedestrian comfort level, but usually worsen it. The effect depends on the depth and height of the setback.

Recessed entries may provide a degree of protection at pedestrian level. The degree of protection depends upon the height and depth of the recess, and the wind patterns experienced locally.

Particular care should be taken when a recessed corner entrance is contemplated as these may accentuate wind effects at corners.

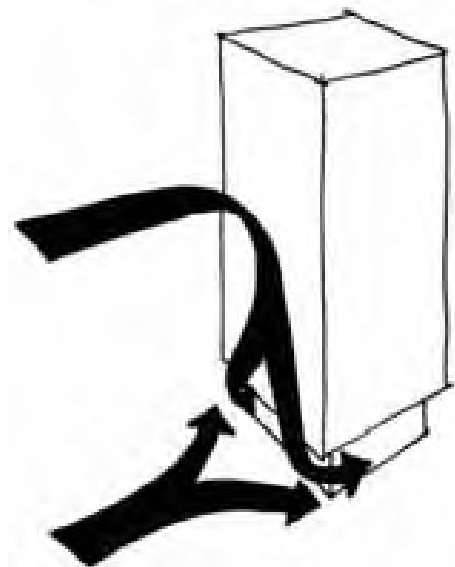

5.3.4 Wake effect

Higher wind speeds and turbulence add to the discomfort felt downwind from buildings. Much of the discomfort occurs as a result of the corner effect, which for 4 to 10 storey buildings, persists for up to 4 times the height of the building downwind of the building and can spread out, as indicated in the diagrams below.

Discomfort levels are worsened by increases in building height. For example, an isolated 60m tower block building causes about a 40 percent increase in the level of discomfort, whereas a 100m building causes a 120 percent increase.

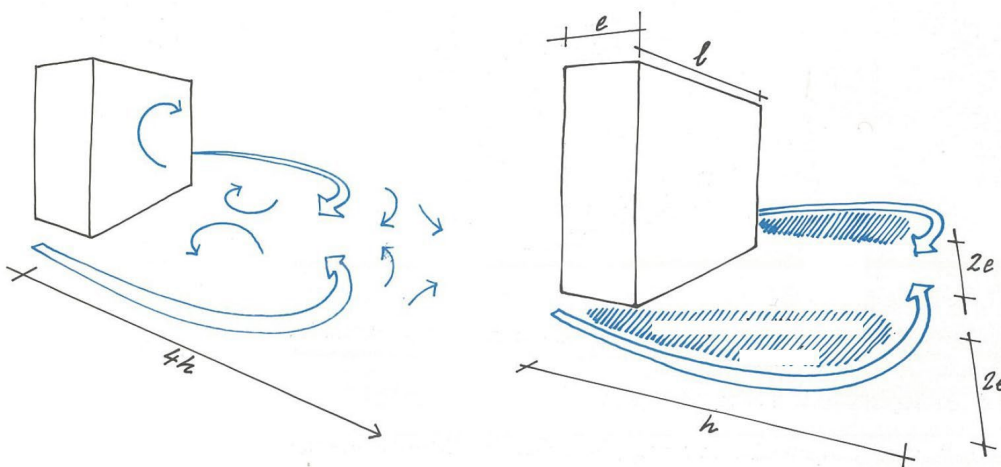
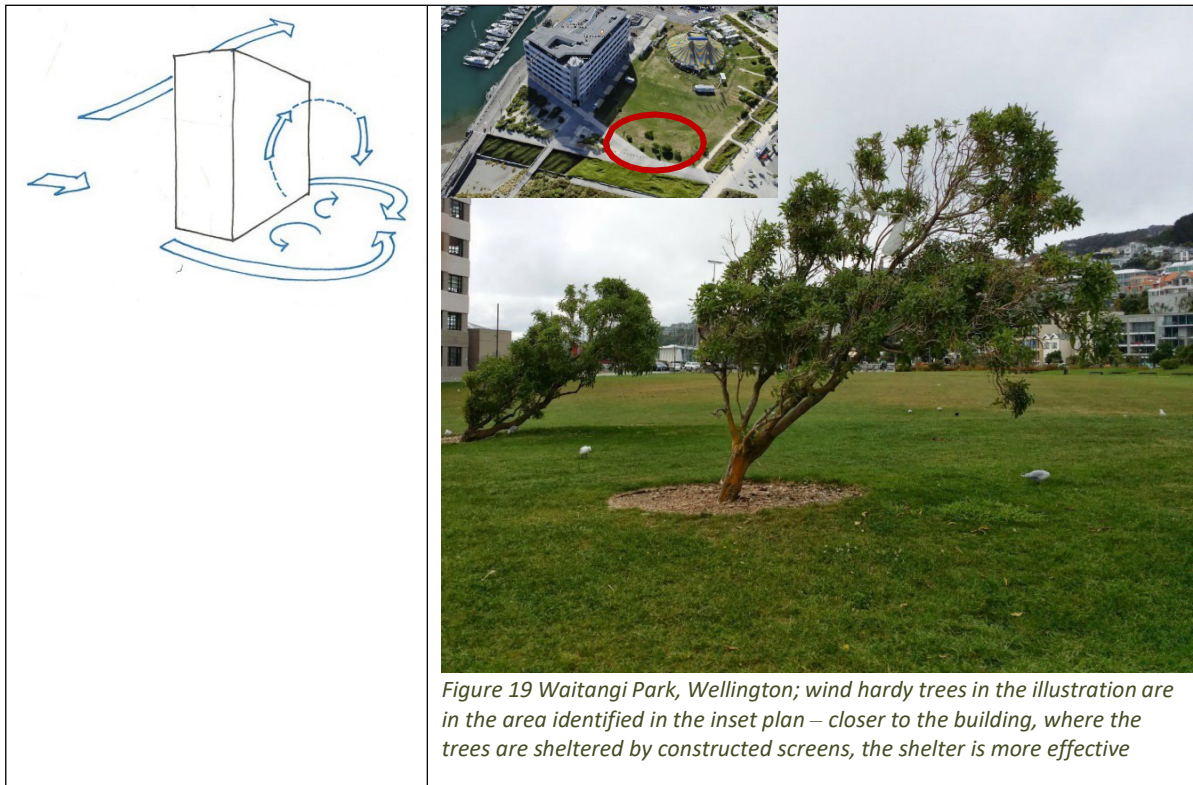

The wake has a characteristic "horseshoe" form. The area particularly affected extends downstream by the height (h) of the building, and extends laterally by twice the depth (e) of the building on both sides of the building.

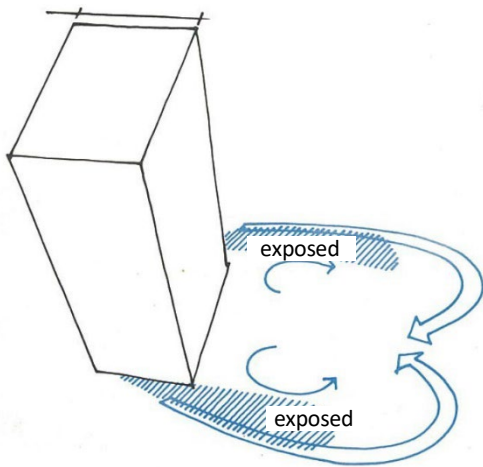

Each building is different in terms of the discomfort it creates and the area of ground it affects. A 16-storey slab block can increase the discomfort level by 60 percent.

The size of the wake is a function of the cross section facing the incident wind.

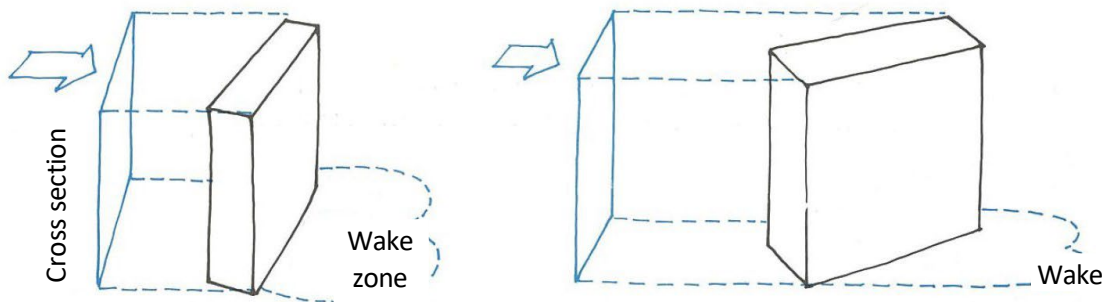

Practical advice

Adverse wake effects are minimised by presenting the smallest cross section of the building to the wind.

Extensive planting can also reduce wake effects.

Care should be taken to ensure that the trees will actually continue grow (*Figure 30*) and provide the required shelter in a windy environment.

The denser the built environment, the more the wake effect is mitigated.

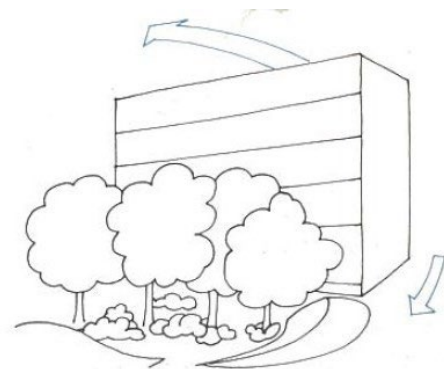

The following examples demonstrate that planting as a solution for strong winds has rarely been successful in Wellington City.



Figure 30 Kate Shepherd Apartments, Wellington, New Zealand. Trees planted by developer as alternative to a canopy wind shelter will never provide the promised shelter, and have become the responsibility of the City Council, not the building owner



Figure 31 "Hamilton Chambers": the trees originally proposed have not established



Figure 32 "Hamilton Chambers" Lambton Quay, Wellington, NZ. Proposed tree wind shelter never grew successfully. Now reduced to shrubs that grow but provide none of the promised shelter

5.3.5 Arcades and colonnades

Arcades and colonnades at the base of exposed buildings can provide openings between the higher pressures of the windward face and lower pressures at ground level through which high wind speeds are induced.

Arcades and colonnades should never be designed as main public access-ways, or as window-shopping precincts unless there is adequate protection from wind.

When there are passages through buildings that effectively connect the high pressure side at the front of the building with the low pressure side at the rear, there can be very significant accelerations of wind through the passageways. This can mean that spaces that might be thought of as 'indoors' experience wind speeds much higher than those experienced *outdoors*.

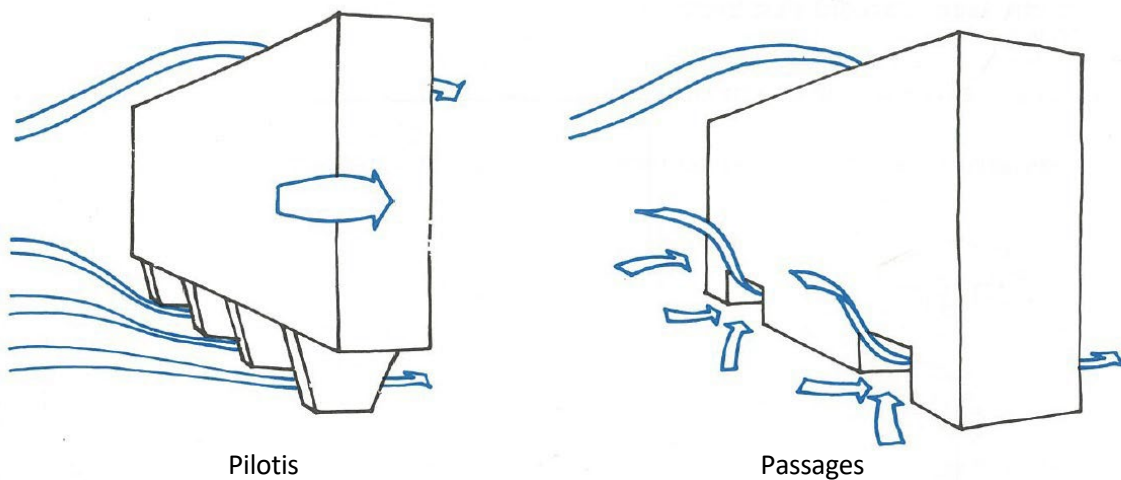

The minimum height of buildings likely to experience significant wind effects from this phenomenon is around 15m.

buildings less than 15m high do not make a big enough screen

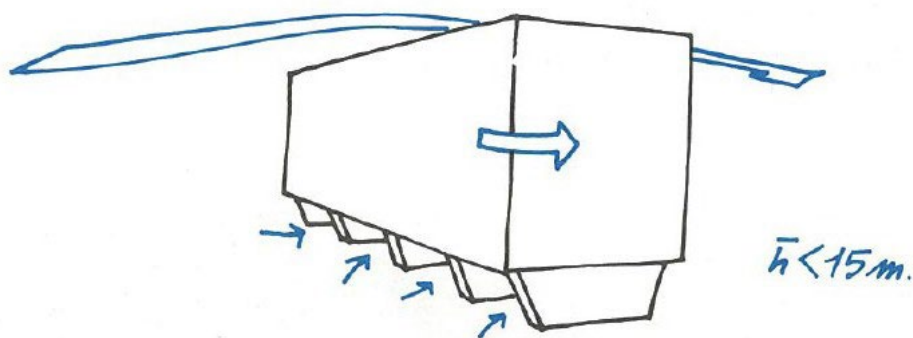

The orientation of the passage through the building affects the magnitude of the accelerations. Also, the nature of the openings underneath the building affects the amount of flow. Where the building is raised on blade-like "pilotis" the accelerations are greater than if there is a corridor cut through the building. Closing these linking passages off with doors may reduce the wind while the doors are closed but they make opening and closing the doors hazardous. Wind lobbies with two opening doors at each end of the passage are seldom effective because to ensure their effective operation, they must be very long (of the order of 10m) to function as intended where the outer door of the lobby is closed before the inner door opens.

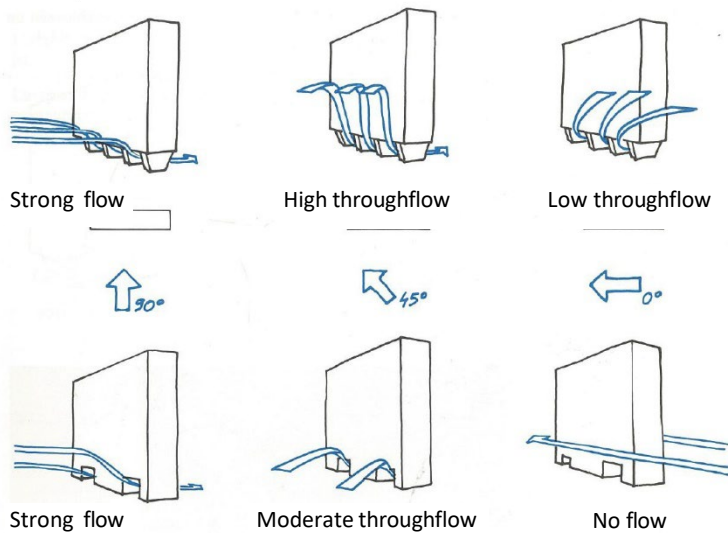

The taller the building, the more pedestrian comfort is reduced. For buildings on “pilotis” the accelerations under a building 20m high are expected to be 20 percent, and for a building 50m high the accelerations experienced under the building are 50%.

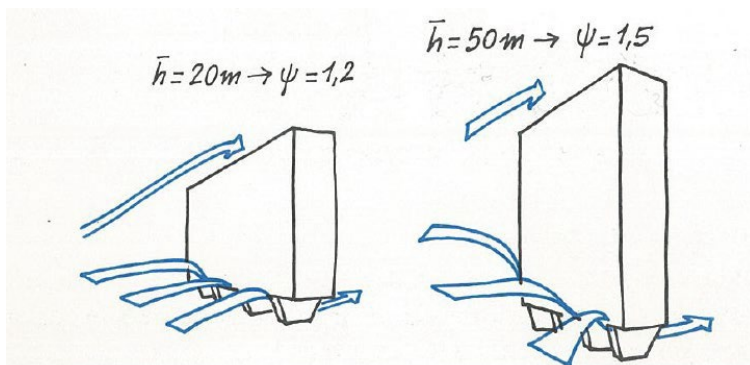

For the same 50m building, the acceleration of wind in normal passages under the building are likely to be 40 percent.

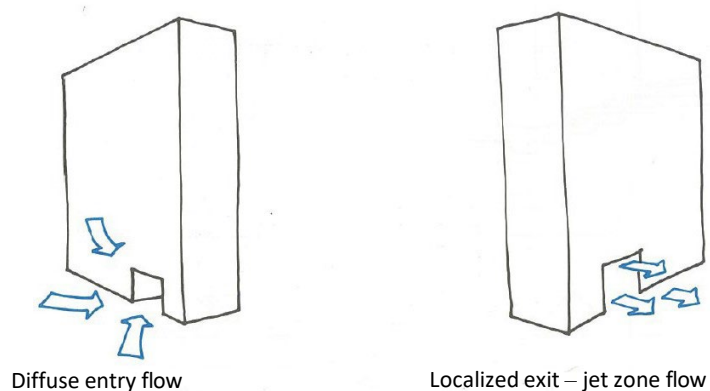

The discomfort zone is not limited to the passage under the building but continues downstream, in the jet zone, over a volume of the same order as that of the hole.

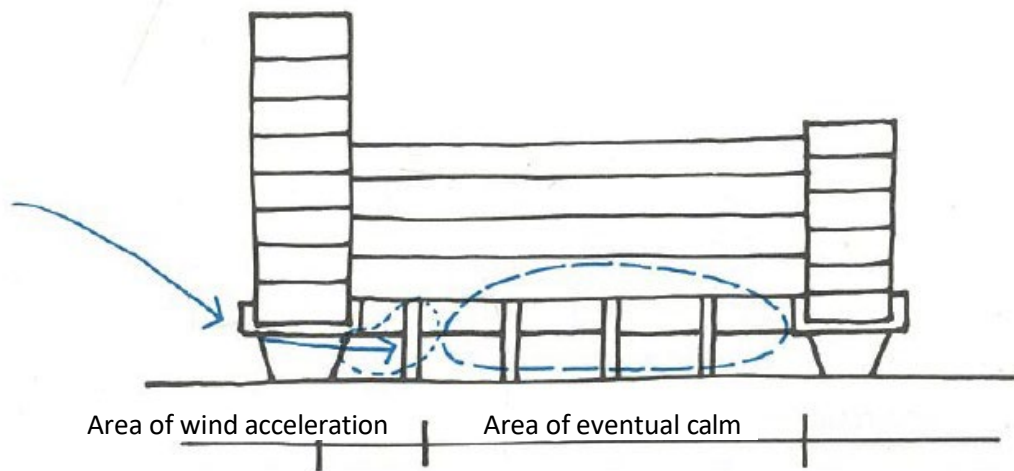
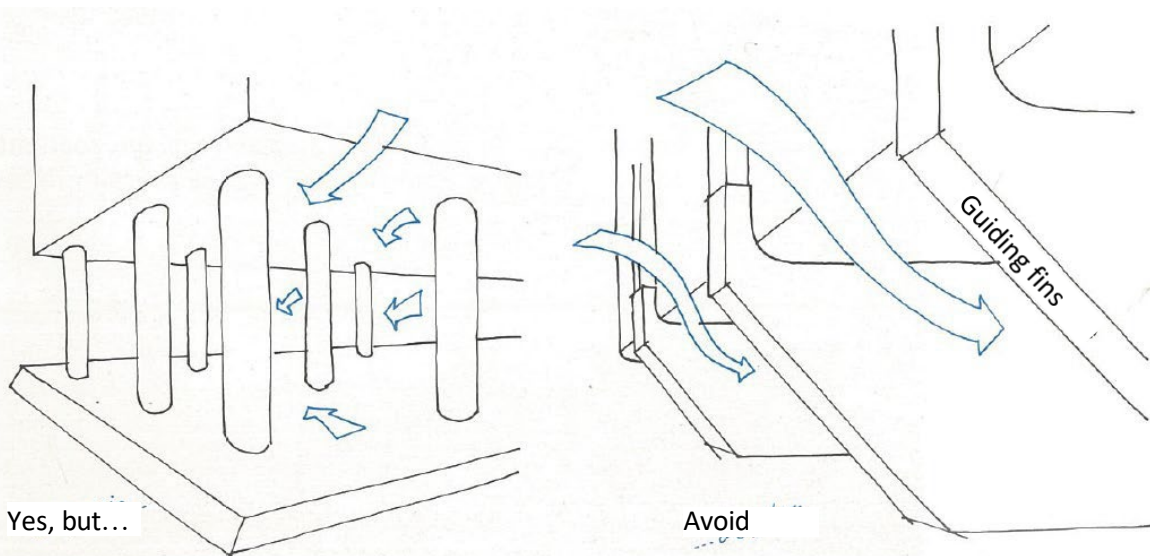

Figure 33 Pilotis can play, in some cases, the role of windbreak

Note: Courtyards surrounded by buildings on stilts can offer acceptable comfort in the courtyard, though not under the buildings themselves.

Practical advice

- Orient buildings on stilts or with "holes" aligned parallel to the wind.
- Provide the base of buildings with vegetation and solid constructed objects to diffuse the flow.
- Introduce at the level of the connecting volumes elements that produce pressure losses.
- Avoid solid-form buildings on pilotis.
- Divide the flows at the foot of buildings by increasing the porosity of the building.



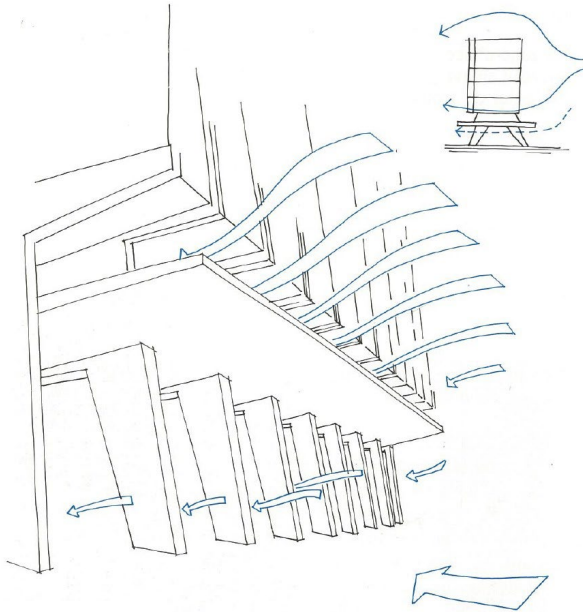

Figure 21 Pilotis (stilts) effect mitigated by a division of the flow

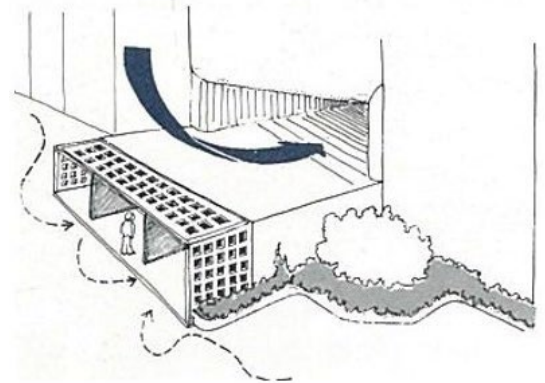

Figure 20 To be fully effective, the passage for pedestrians is separated from the air dissipation flow vertically and horizontally



Figure 22 Example from Wellington of divided flows to reduce the problems at the foot of buildings by increasing the porosity of the building - car park levels at first floor and above – with retail below

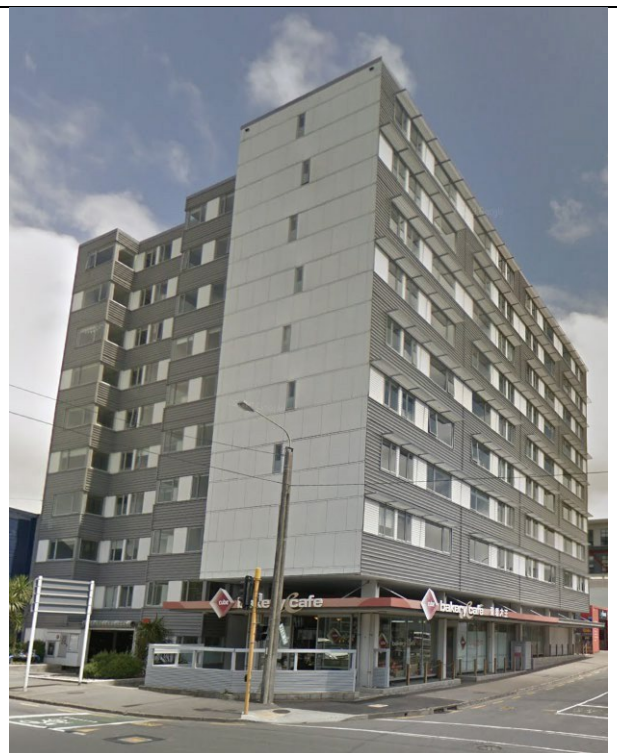

Figure 23 Example from Wellington of divided flows to reduce the problems at the foot of buildings by increasing the porosity of the building - slot through the building <1m high at first floor above retail

5.3.6 Pedestrian corridors and foyers

The designer's responsibility for adverse wind effects does not end once wind conditions in the street have been addressed. The entrances to buildings, foyers and pedestrian corridors can also be areas where there is pedestrian discomfort or even danger.

Discomfort can be experienced both inside and outside entrance doorways. There may be a high fluctuating wind pressure outside the doorway, which creates a high pressure on the door itself, and given the opportunity, generates a wind flow into the building. Wind whistles through gaps, and doors bang. There are both damage and safety risks, and there can be difficulty in operating doors and lifts. In extremely bad situations, it is not unknown for lift doors to jam because of the severe local wind pressure.

Increases in wind pressure can turn stairwells and corridors into unpleasant wind tunnels, and can disrupt heating and ventilation systems. Buildings adversely affected by wind may require three to four times more heating than unaffected buildings.

Practical advice:

Entrance-ways to building foyers and pedestrian corridors should be designed or located to avoid users experiencing adverse wind conditions. This means:

- locating them well away from the corners of buildings;
- not linking through the building so that the high pressure on the wind facing façade is linked to the suction on the rear of building, even if via wind lobbies on each façade;
- ensuring that doors can operate safely without risking jamming fingers;
- designing effective wind lobbies where the inner and outer doors are sufficiently spaced apart that one will close before the other opens – this normally means spacings closer to 10m than 3m in an office building; and
- looking to ensure the doors into a wind lobby are not directly facing each other to reduce the direct flow of wind into the building

6.0 Interaction between groups of buildings and wind

It is not possible to predict what the effect of a proposed building or open space will be on wind conditions around adjacent developments without a Quantitative Wind Study. Unexpected wind patterns can and do occur. This section, like the previous section, is intended first as guidance during early design to the potential interactions of groups of building with the wind. It is intended that it is also used during the analyses in Qualitative Wind Assessments and Quantitative Wind Reports to document the likely impact of a proposed building and provide a rationale for the selection of potential remedial design interventions.

The wind effects described in section 5 all relate to the interaction of a single building with the wind. When groups of buildings are being assessed, the wind effects can be cumulative and all the buildings need to be considered.

This combined increase in wind speed may be substantially reduced if existing or subsequent buildings nearby are of suitable height to give a localised stepping-down effect. This may occur where the difference in height between the protruding building and windward adjacent buildings is less than one-third the height of the protruding building.

6.1 Low bar buildings (“row” effect)

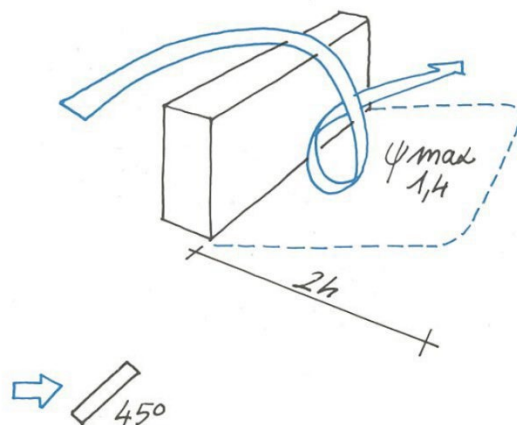

Low, “bar”-shaped buildings which present wide unshielded faces exposed to any prevailing winds cause the wind to literally ‘trip’ over these bars. When a building or group of buildings is narrow, less than 10 storeys high, and its length is approximately eight or more times its height, and the wind is incident at roughly 45 degrees to the row then a 40 percent increase in discomfort can be expected behind the building for a distance roughly 2 times the height (h) of the building.

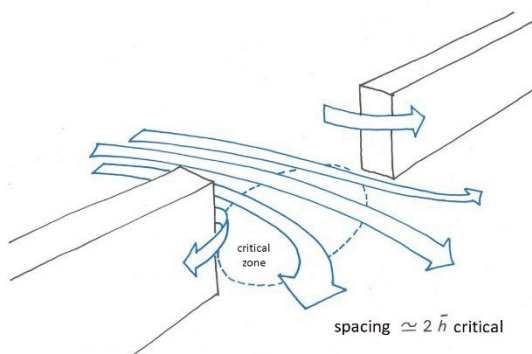

Where there are openings in a row, and the row is up to 8 storeys in height (and the predominant wind is angled at the row), an up to 30 percent increase in discomfort level may be experienced when the width of the opening is one to two times the height of the row.

6.1.1 Practical advice

The row effect can be reduced, or even cancelled, by adding one or several wings to the main block, thus localising the pedestrian wind level disturbances. To be effective these wings should extend away from the building by roughly 2 times the building height.

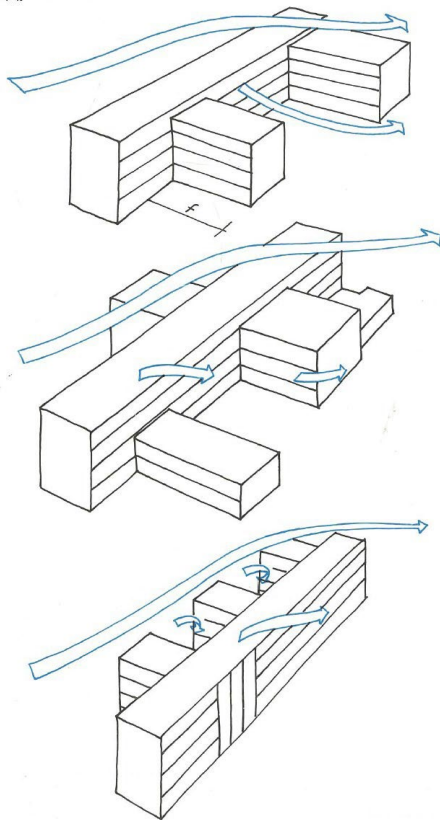
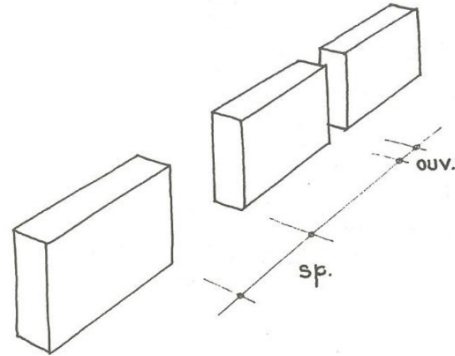
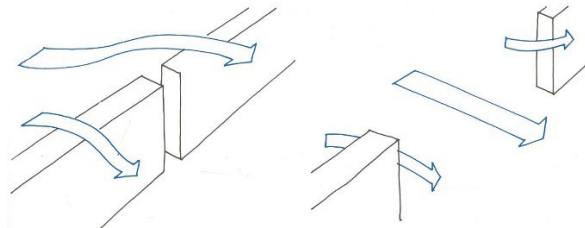

Figure 24 The flow cannot roll over the row: "overall" behaviour of the form.

The openings in a row of buildings are areas where accelerated wind flow can occur and there is a critical dimension where the wind is accelerated.



Space buildings less than their height (h) apart, or more than twice their height ($2h$) apart to avoid wind accelerating through the gaps, then porosity is such that geometrically there is no row.



6.2 Low and high buildings in combination

When wind flows over rows of buildings of a similar height, as in older parts of a town, pedestrian areas are generally sheltered; usually considerably better than if there were no buildings at all.

However, where a low building is upstream of a high building and the high building exceeds five storeys, there are likely to be major problems/increases in discomfort at ground level.

For example, downwash from a 90-100m (30-storey) high building with a wide windward face will cause a 50 percent increase in discomfort at its base when the building is on its own. There would be an 80 percent increase in discomfort if there were a low (e.g., 10-15m) building upstream of the tall building, that is spaced at a distance approximately equal to the low building's height upstream. A low 4 storey building 'tripping' the wind flow in front of a 10 storey building would lead to a wind speed increase of 50% at the base of the 10 storey building.

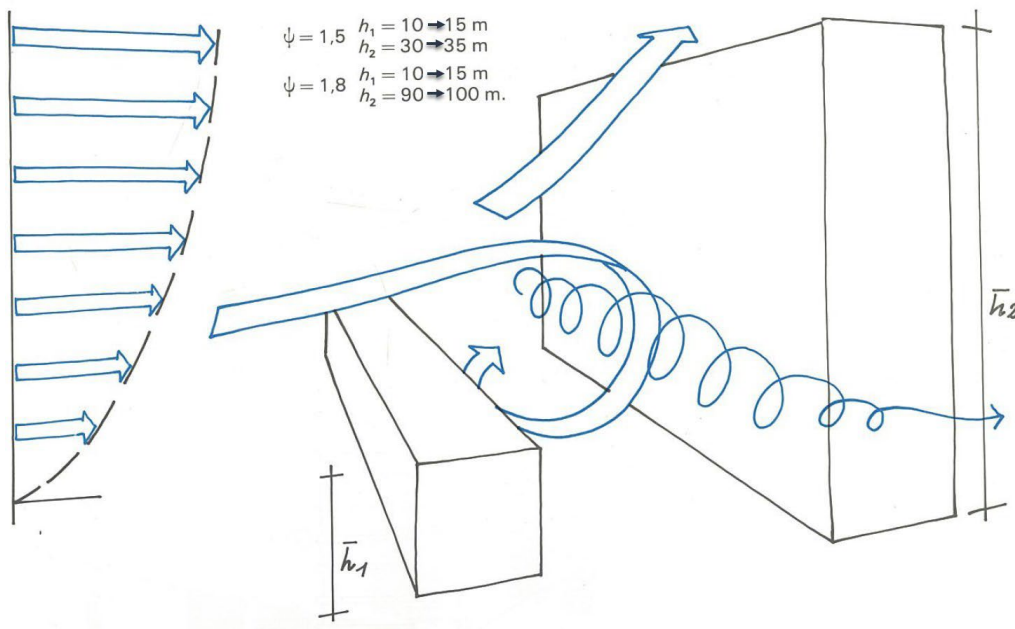

Figure 25 Accelerations due to associations of buildings of different heights: factor ψ represents how much the wind flow is accelerated: $\psi = 1.5$ = multiply wind with no buildings by 1.5 or a 50% increase in wind

Practical advice:

- Avoid critical associations or cover the exposed area.

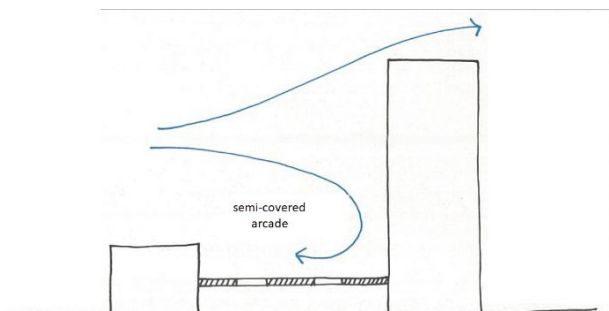

Figure 40 A potential solution to downwash is to provide a cover that diffuses the wind

6.3 Staggered buildings

Adjacent buildings may protect each other from high winds, or may make their wind environment worse. The buildings in *Figure 41* show an increased wind pressure on the unsheltered area (+) and a decreased pressure at the sheltered areas (-). Consequently, wind rushes from the high pressure point to the low pressure area. This effect is significant because of:

- the large area at ground level which is affected (the area is related to the height of the buildings – the distance between the buildings should be less than their average height for the acceleration to be significant);
- the ways that the massing/scale of the buildings and relationship to other buildings can exacerbate the adverse wind effects. Discomfort levels are wide-ranging, depending upon the scale and interrelationship of the staggered buildings and other building nearby; and
- For the phenomenon to exist the minimum average height of the buildings is approximately 15m. The effect is felt in the whole area of overlap of the buildings.

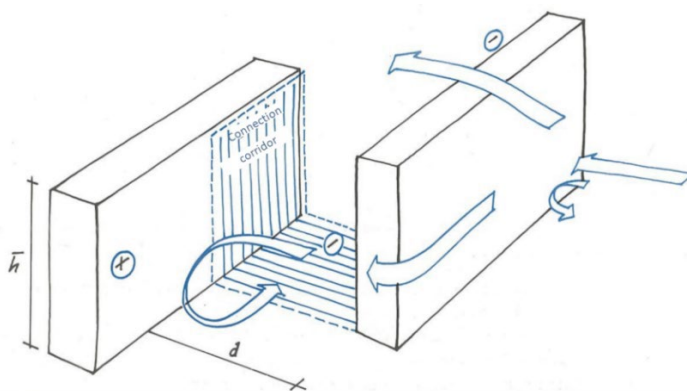

Figure 41 The anomaly affects the entire connection 'corridor'.

The staggered buildings effect, especially when associated with other phenomena, leads to unexpected changes of wind direction in city streets. This is particularly bad in terms of discomfort that is experienced.

For a 15m tall buildings, the anticipated acceleration in the overlap zone is 20 percent. For a 35m tall buildings the acceleration is between 30 and 60 percent.

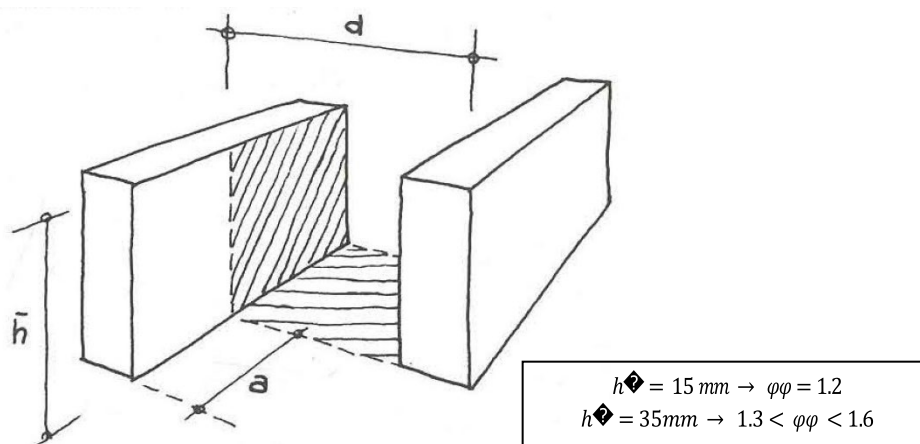

Figure 42 Quantification of the effect of height on the phenomenon

For two towers spaced relatively close together the acceleration in the overlap zone can be up to 80 percent. In this case the worst effect is when the distance apart of the towers is one quarter of the depth of the towers in the windward direction.

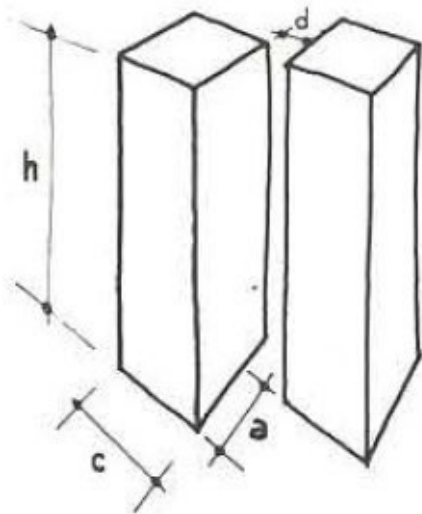
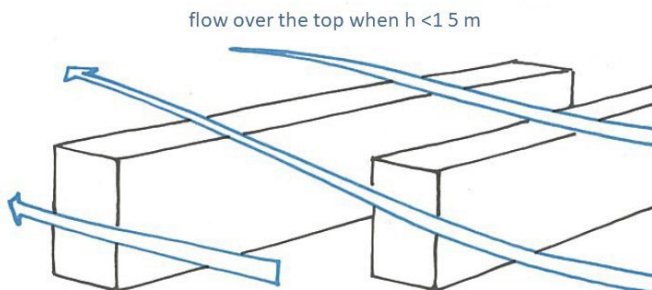

Figure 26 The worst wind accelerations in the gap between the tall towers occurs when $d \approx c/4$ then $\psi \approx 1.8$ (acceleration = 80%)

6.3.1 Practical advice:

- The phenomenon does not occur if buildings are less than 15m high.



- If a link corridor is poorly defined (low porosity or flow blocking element), the phenomenon does not occur.

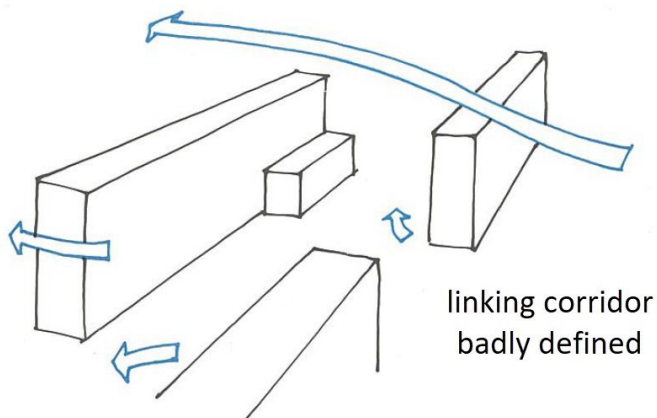

- The phenomenon does not occur if the unsheltered area of the leeward buildings is too narrow. The width of the unsheltered area must be at least the height of the building, $a \geq h$

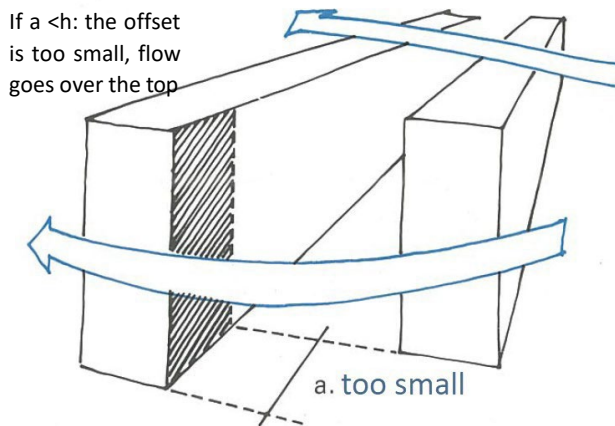

6.4 Channel effect

A row of buildings running more or less parallel to each other forming a channel or corridor is not in itself a cause of discomfort, but it can cause discomfort when it receives some other adverse wind conditions and transmits them for the whole length of the corridor. Adverse wind effects are accentuated when the corridor is well-defined (such as there being few gaps and generally similar height buildings) and is relatively narrow (when the width between rows is less than three times the buildings' height). The channel effect can be reduced by the introduction of sharp changes in direction.

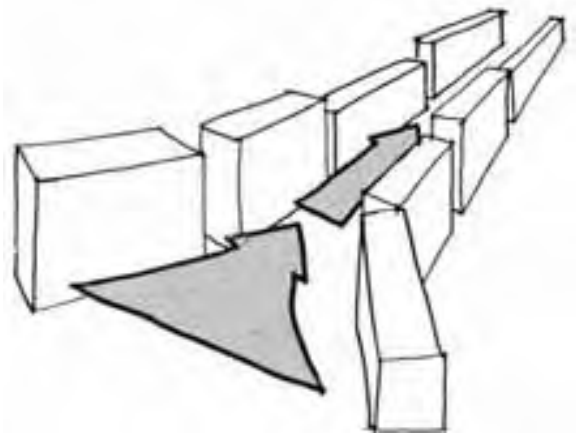

6.4.1 Practical advice:

If all the other aerodynamic anomalies such as too tall buildings, or close groupings of buildings are avoided, then there should be no concern about channelling as there should be little wind to channel.

6.5 Funnelling effect

This collector, or “bottleneck”, phenomenon is created by two structures with an opening between them. The axes of the two may make a right angle or an acute angle. The critical zone for comfort is at the neck (the narrowest section of the gap between the buildings).

Significant funnelling effects occur when the relevant buildings are more than five storeys high, more than 100 metres long, and the upstream and downstream funnels are clear of obstructions.

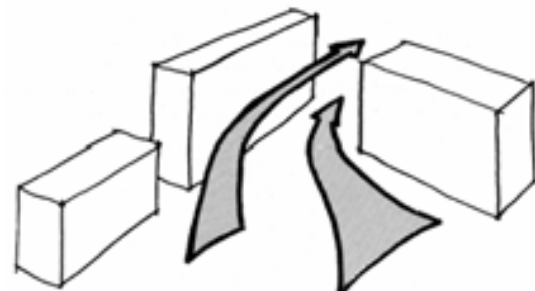

6.5.1 Practical advice:

There are several “critical dimensions” to be avoided, or to be identified and mitigated in order to prevent the funnelling effect.

Discomfort is worst when the width of the opening is two to three times the mean height.

Buildings 30m high cause a 30 percent increase in discomfort and buildings 60m high cause a 60 percent increase.

There is a greater wind acceleration where the venturi effect applies. If, after a bottleneck, the rows of buildings diverge, then an aerodynamic nozzle is formed, and wind will accelerate once past the bottleneck. In this situation, building heights of about 15m storeys could cause a 100 percent increase in discomfort level.

If one or more of the buildings forming the acute angle is also curved in plan, a more aerodynamic venturi is created and the wind problem is increased.

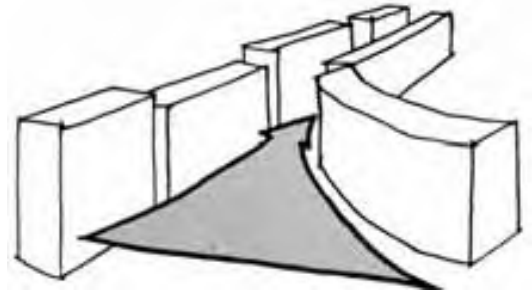

6.6 Stepping effect

Groups of buildings which present a windward face which increases continuously in height create varying pressure zones on the lee side. Differing low-pressure zones will occur behind the different buildings. An additional wind current, often at an acute angle to the prevailing wind, will be set up between these varying low-pressure areas.

6.6.1 Practical advice:

This is a situation to be aware of, and to try to avoid creating adjacent buildings with incrementally increasing or decreasing heights.



6.7 Courtyard effect

When buildings are linked together to form an open courtyard, the wind will either flow over the courtyard, or blow down into it. The following four factors have been measured in wind tunnel experiments as determining which of these two possibilities will happen:

- the surface area of the courtyard (s)
- the mean height of the buildings forming the courtyard (h)
- the position of any courtyard opening with respect to the wind direction
- the width (w) of that opening, or total width of openings (w must be less than or equal to 25 percent of the total perimeter length of the linked buildings).

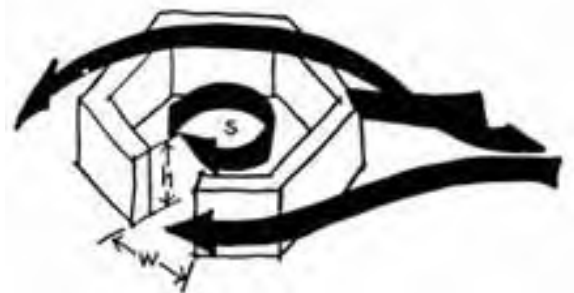

6.7.1 Practical advice:

The sheltering value of the courtyard is felt when the average building height is five to eight storeys, no matter where the position of the opening is relative to the wind direction. So long as the area/height ratio (s/h^2) is no more than 10, then the courtyard area will be relatively sheltered.

When the average height of the surrounding buildings exceeds 10 storeys, the opening relative to the wind's direction has an effect on the shelter:

- when the opening is on the leeward side and the area/height ratio (s/h^2) is less than 30, the courtyard will be sheltered
- when the opening is on the windward side to within 45 degrees of the prevailing wind direction, the air in the courtyard will be set into a circular motion. With the opening parallel to the wind the courtyard will be sheltered.

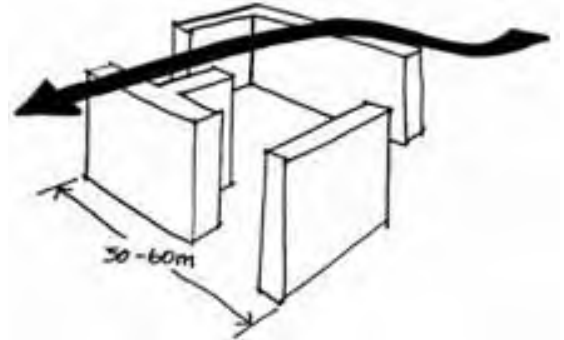

Generally, if the average height of buildings exceeds four storeys, then there will be an increase in comfort within the courtyard – even in a poorly defined courtyard system – where the system measures 50 to 60 metres across.

7.0 Architectural detailing design guidelines

Different, complex wind pressures caused by arcades, spaces under buildings or around corners can induce very rapid local wind flows, which give unpleasant, sometimes violent, wind effects.

Various features such as verandahs and channels on the outside of buildings can have a marked influence on combating adverse wind effects.

These should not be regarded as cosmetic remedies which can be subsequently applied, if necessary, to cure pedestrian-level wind problems for developments in sensitive areas. There is no adequate substitute for the careful consideration of wind at pre-design stage. This could consist of testing simple block forms in a wind tunnel.

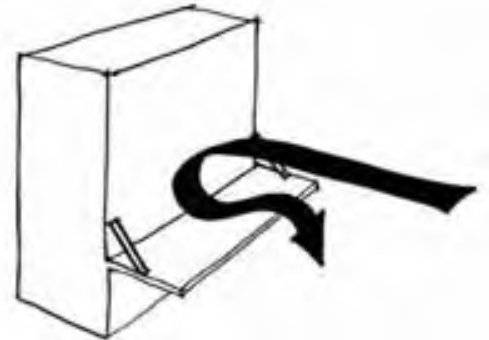

7.1 Verandahs and canopies

Verandahs are substantial structures extending from a building to roof-in adjacent airspace, whilst canopies are minor extension covers over doorways, windows or similar.

Canopies, unless extensive, do little to protect an area from high wind speeds.

- Verandahs should be used to deflect downwash flows, in effect lifting the vortex above pedestrian level.
- They can be used in conjunction with breezeways, although the associated spaces should not be open to pedestrian movement.

Verandahs are not as effective for problematic wind flows that are parallel to the building face to which they are attached. Verandahs are less effective when they are not continuous and large gaps between verandahs allow accelerated wind currents to flow through the gaps.

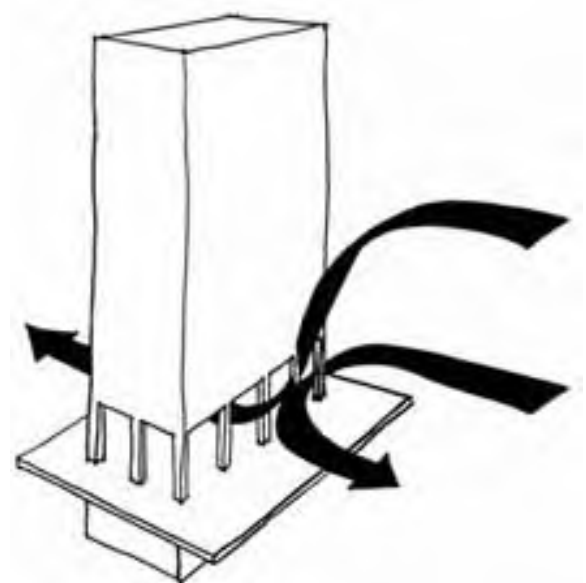

7.2 Awareness of existing wind mitigation

Alterations to existing buildings should not cause wind conditions to deteriorate as a consequence of removing existing mitigation measures that were specifically incorporated to ameliorate wind. Over time the utility of podiums, canopies, screens, planting and other design features described in this guide can be forgotten. It is therefore incumbent upon owners and designers to understand the wind performance of existing building before altering them.

8.0 Wind mitigation

This section describes the basic aerodynamics of isolated structures and windbreak elements, singly and in combination, that can contribute to mitigation of wind issues. A windbreak structure could be:

- a verandah;
- a canopy;
- a hedge;
- a wall; or
- some combination of these.

Where modification of the building itself is not feasible, it may sometimes be useful to provide localised amelioration through the addition of aerodynamic screening elements. It is never desirable to place a screening element in public spaces, or worse, in front of another building, in order to solve an issue that could have been resolved within the development. However, a recognised principle of good aerodynamic design is that the closer the screening element is to the people to be protected, the greater its likely success in reducing wind speeds. The design principles to be applied to alterations to buildings or to isolated screening elements are described in a similar format to the earlier descriptions of the impacts of buildings on wind flows.

Remedial treatment is never a reasonable substitute for the proper consideration of wind effects during the design of a project.

8.1 Structures

Where buildings prove to be windy after construction, various remedial works may substantially reduce the adverse wind effects.

Two approaches may be taken:

- people can be protected by shields; or
- they may be redirected through safer areas, for example by establishing gardens and architectural features within the danger zones.

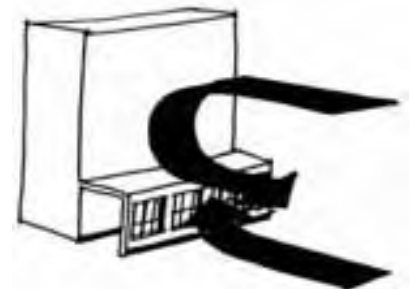

In more extreme situations, the second course is recommended.

8.1.1 Verandahs

A substantial verandah may prevent high wind speeds descending to ground level. However, care must be taken not to transfer the discomfort to another pedestrian area.

8.1.2 Enclosed walkways

The shelter effect of a verandah can be extended by the addition of a side wall.

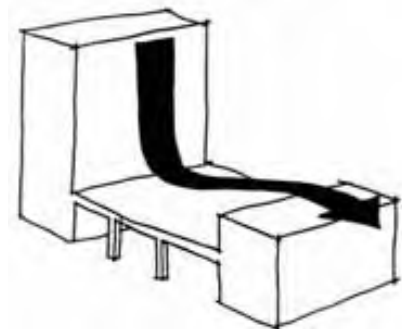

8.1.3 Roofing over the open spaces

High pedestrian-usage areas such as shopping precincts can be roofed over.

8.1.4 Pedestrian corridors and foyers

Although enclosing the walkways improves the wind conditions, there may be significant discomfort from winds induced along the entire length of the enclosed walkways.

These may be reduced by putting up screens, or eradicated by building doors at the end of the walkways. Although the addition of such doors will eliminate the wind problems in the corridor, there may well be major problems at the doors - people may have trouble passing through the doors, or the doors may jam. Electronic doors often cannot operate under large wind pressures.

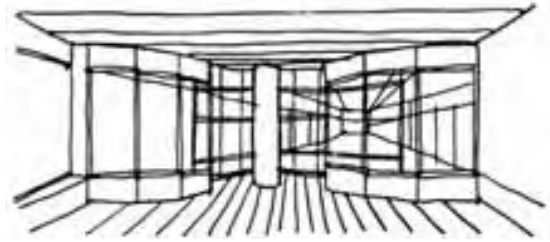

8.2 Windbreaks

Definition: A windbreak can be a single item (screen for example) or a system of devices which, by its presence in the wind flow, reduces the effect of the latter (level of speed, turbulence, etc.) while within the system itself (case of several elements) only on one certain downstream distance.

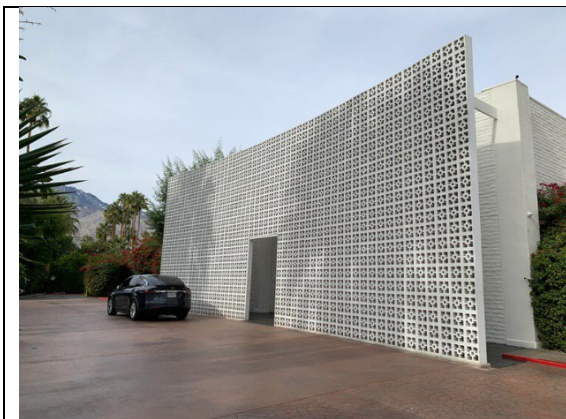

Figure 44: Concrete breeze block shade screen on the Parker Palm Springs Hotel (Source: <https://bit.ly/3iGNLSA>). In another context, this could be a wind break with porosity ~50%



Figure 27 Illustration from Farm Forestry New Zealand Guide to wind shelter on farms as association of wind breaks (Source: <https://bit.ly/ShelterFarms>)

8.2.1 Independent windbreaks

Only in exceptional circumstances can individual screening elements be provided for each person. The bathing chairs of Northern Europe (Figure 46) are an idealised extension of the simple wind screening element also common at the beach in the windier parts of Europe (Figure 47). But these examples demonstrate the problem of providing individual shelter: they can often impede general pedestrian access.



Figure 28 Beach "chairs" facing the sun and away from the sea breezes, Warnemunde, North Germany



Figure 47 Example of Beach Windbreaks (Source: https://www.beaufort.be/assets/upload/stranduitbating/strandparasol_5.jpg)

8.2.2 Wind flows around windbreaks – protection factor

The most basic windbreak will consist of a solid obstacle (wall) or a porous obstacle (screen, hedge, palisade, etc.). The height of such walls and screens remains generally small compared to their length, and wind flows are essentially deflected above (except the ends of the wall/screen).

In this guide porosity is a number between 1 and zero where 0 is solid, 0.50 is equal parts open and solid, and 1 is completely open (i.e., no screen). Alternatively, the porosity may be expressed as a percentage, where 0% is solid and 100% is completely open (i.e. no screen).

If the windbreak has a large porosity, part of the incident flow passes through the windbreak, which suppresses the formation of vortex circulations downstream.

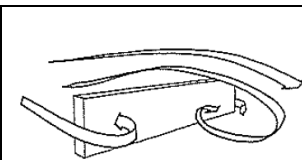

Flow around a solid wall

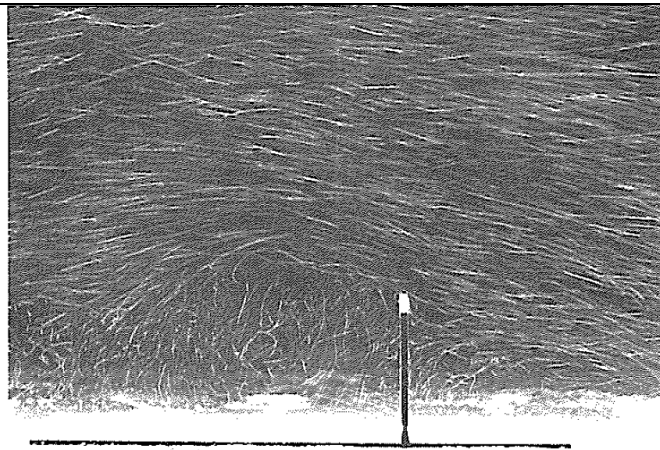

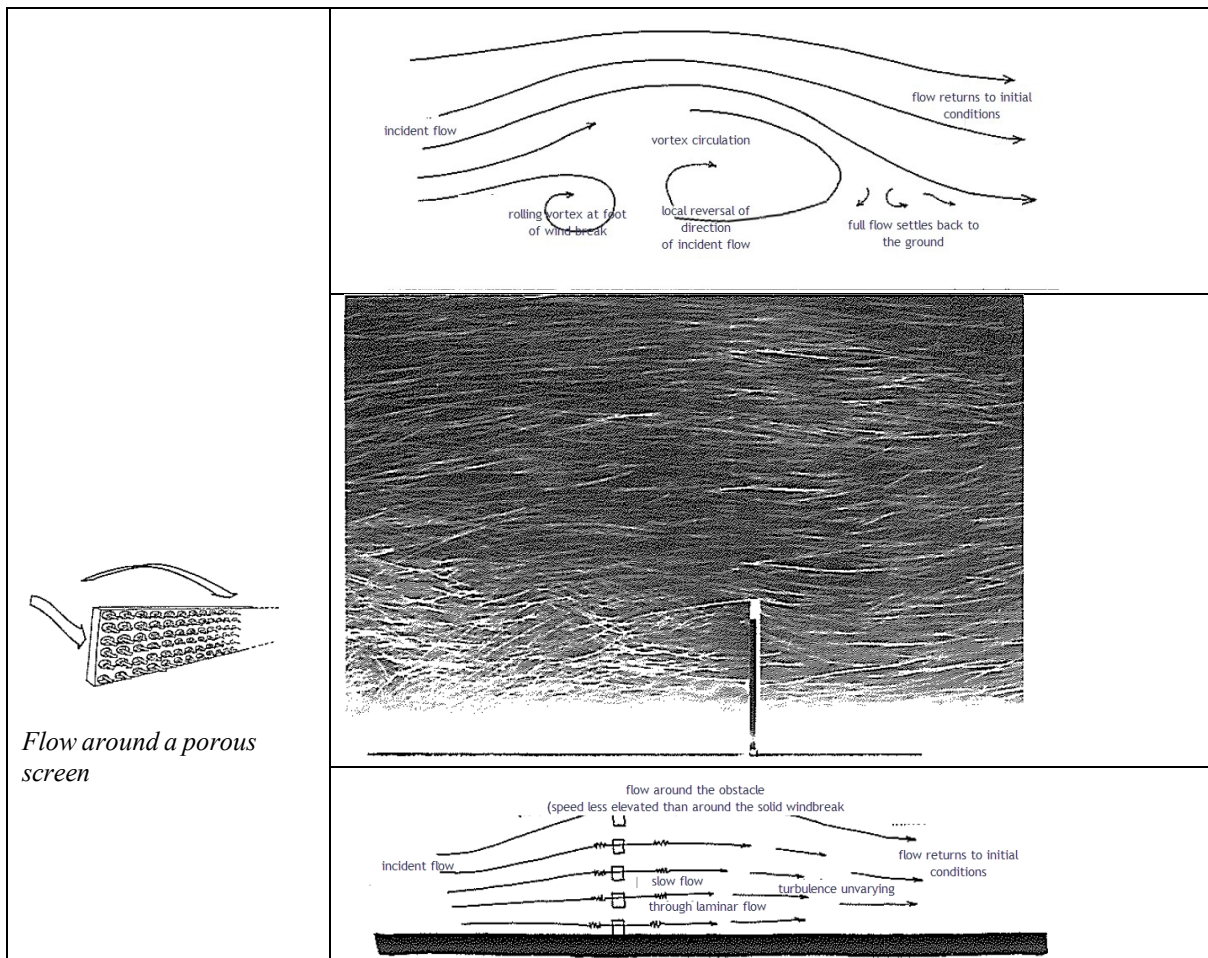

Flow around a porous screen

The images above illustrate the different wind flow around a solid wall and a porous screen. The windbreak begins to act on the flow approximately one times its height upstream of the windbreak (foot swirl and upward deflection), and above all, strongly modifies the flow downstream by forming a wake. Only at a distance some twenty times the height of the windbreak downwind has the flow recovered to be like the undisturbed upstream flow.

8.2.3 Windbreak protection factor: application to user discomfort

In order to quantify the modified area downstream of a windbreak device, and as a result be able to compare one device with another, a “protection factor” is used to describe the effectiveness of the windbreak, regardless of the speed or turbulence. This protection factor, P , is the ratio between the wind with and without the wind break.

In the following pages, the results of many wind tunnel tests are reported for winds at the height of a person (1.5 m), for a grid of points in the wake of the windbreak. Three levels of protection are reported: $P = 3$, where the wind is one third that with no windbreak; $P=2$, where the wind speed is halved; and $P=1.2$, indicating a minor improvement of 20%.

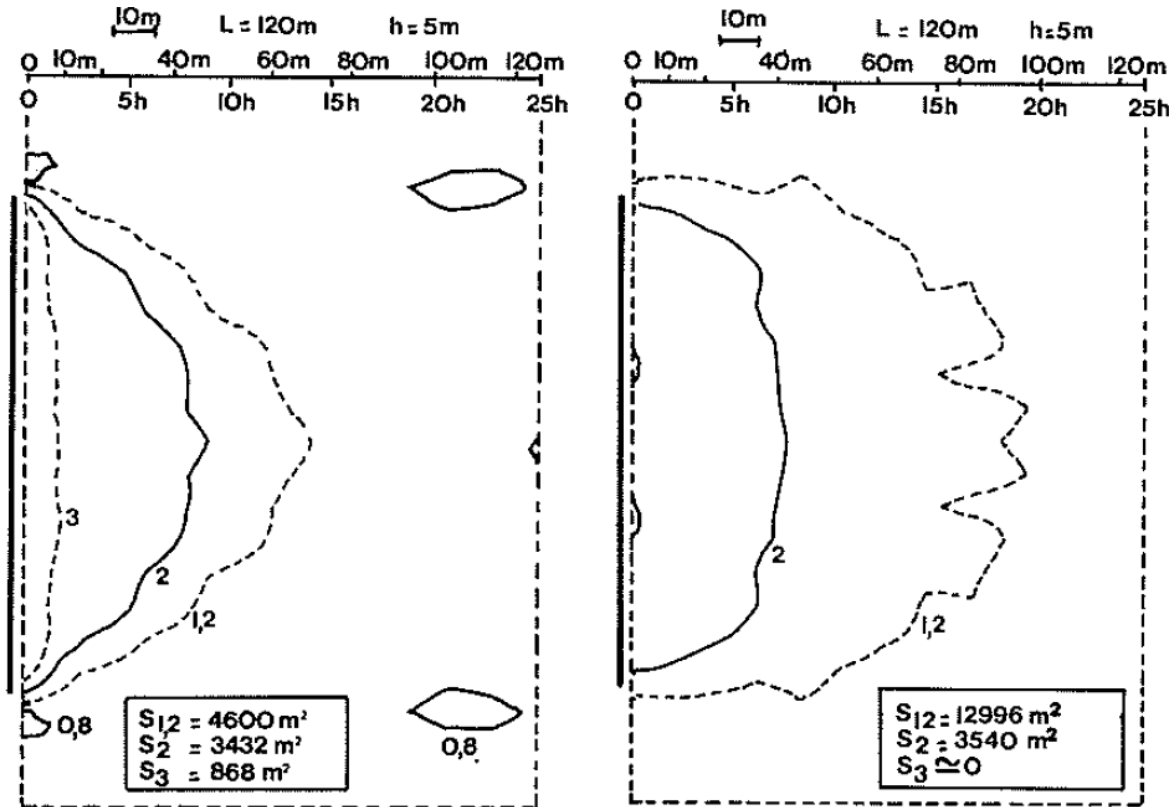
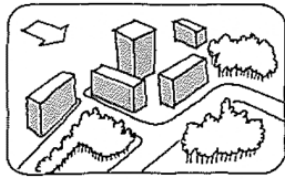

Figure 29 Isoprotection contours at a height of 1.5 m behind a solid wall (left) and a 54% porous screen (right), drawn from results of wind tunnel tests.

Figure 48 illustrates wind tunnel test results for the two windbreak visualizations on the previous page: each is of a wind shelter device 120m long and 5m high. Wind is blowing from left to right. The distance that the shelter extends from each device provides is shown by the horizontal scale at the top of the graphs which is expressed in two ways: in total metres, and in multiples of the height of the device. The porous (54% holes) screen on the right has an effect out to 20 times the height of 5m, while the solid wall has an effect only out to 15 times the height downwind. The area sheltered ($S_{1,2}$) to isoprotection level 1.2 (a 20% improvement) is almost 3 times that for the solid wall (12966m² compared to 4600m²). However, the sheltered area (S_2) is almost the same for both devices inside the isoprotection level 2 line, where the wind speed is reduced to at least half of the wind with no wall. At protection level 3, where the wind behind the barrier is reduced to one third of that with no windbreak device, the solid barrier provides protection 1-2 times the height downwind for a total area of 868m²; but there is no protection at this level behind the porous screen. It is also important to note that the wind accelerates around the ends of the solid wall reaching 20% more than would be experienced with no windbreak.

The action of windbreak elements, that is, how the speed (magnitude and distribution) and the turbulence will be modified by their presence, depends on a complex combination between the scale of the obstacle, the aerodynamics of the windbreak (in particular the resistance to wind), the characteristics of the incident wind and the presence of an immediate environment.



The statistical nature of the wind (i.e. roughness)

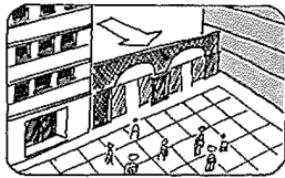

The dimensions of the windbreak

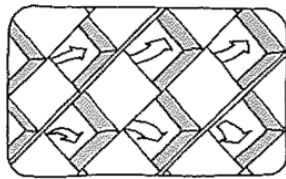

Windbreak aerodynamics

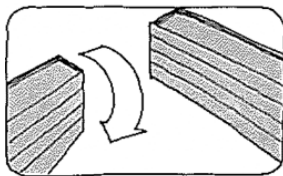

The constitution of the immediate environment

Figure 49: Elements of a windbreak function

8.3 The functions of a windbreak

Whatever the field of application (inconvenience and safety of the user or civil engineering), any protective effect will be obtained from the control of:

- 1) the speed level and its spatial variation (horizontally and vertically);
- 2) the turbulence rate and its homogeneity; and
- 3) the axis and direction of flow.

Therefore, the device can have the following functions:

- Slow down the air flows by introducing obstacles into the flow that dissipates kinetic energy. For example, the flows through orifices or increasing the friction of the ground by varying its surface roughness.
- Breakup the turbulence by reducing the dimensions of the vortices. The viscosity of the air induces a damping effect on small scale turbulence. Wire mesh or nets fulfill this role remarkably well.

- Redirect the flows to shelter "wind sensitive" areas of a building or landscape.
- Destroy strong wind flows by “three-dimensional bursting” (i.e. deflect the flow in all directions) that breaks down the coherence and concentration of the flow. Sculptures or stabiles can perfectly fulfill this function as shown on the photograph to the right showing an example on the corner of Tory Street and Cable Street.

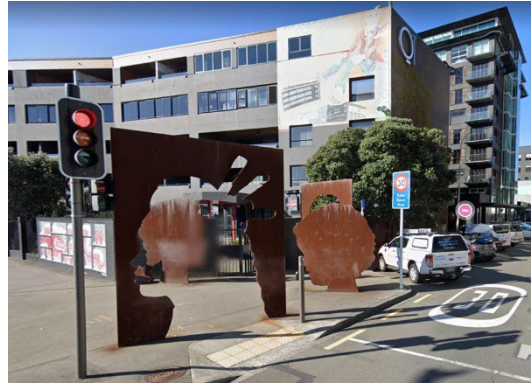

It should be mentioned that the interventions or devices generally combine several of these functions. In addition, depending on the nature of the protection to be introduced, the aerodynamic solution to be provided and the device which results therefrom may be very different.



Figure 50 Rozenburg wind wall in Rozenburg, Netherlands, eases the passage of large cargo ships through the narrow canal. The wall blocks about 75% of the of the wind. It is 1600 meters long and is made up of 125 rectangular and cylindrical slabs, each about 25 meters tall and 18 meters wide. (Source: <https://bit.ly/2SKLeCG>)



Figure 51 Porous metal screens enabling wind hardy plants to grow beside the harbour in Wellington, New Zealand



Figure 52 Porous wooden screen for pedestrian protection – harbour front Wellington, New Zealand.

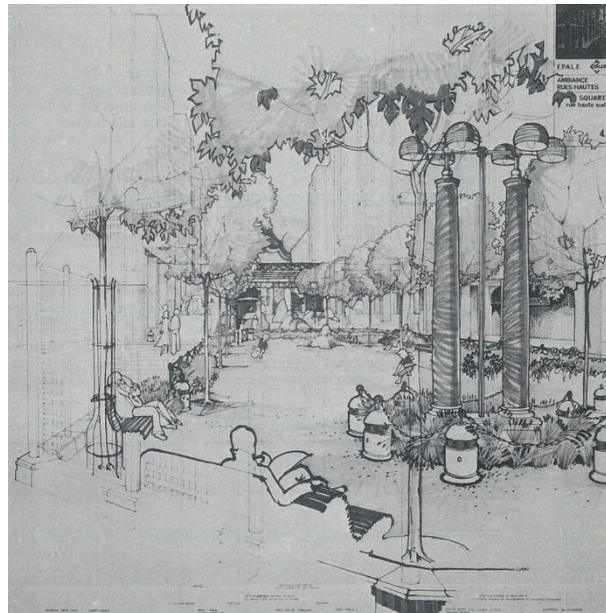

Figure 53 Shopping street development project in Lille-Est (integration of several windbreak interventions)
Architect: Canivet

8.3.1 Vegetation

The growth of trees in the area adjacent to buildings can be prevented or distorted by the wind. However, resistant vegetation can act as a porous screen and calm wind flows, whereas a solid wall or fence could create further pressure variations.

8.4 Cross-section shape of a windbreak

If the "depth" (dimension in the direction of the wind) of an obstacle is at least 30 m (a significant dimension relative to the scale of wind gusts) and the obstacle is solid, the cross-section geometry (in particular the profile of the windward face) affects the wind flow and shelter it provides. However, normally shaping the profile of a windbreak will not lead to a significant gain in protection.

8.4.1 Practical advice

The example in *Figure 54* of a “springboard slope” illustrates the minimum dimensions required to shelter an area downwind by redirecting wind flows.

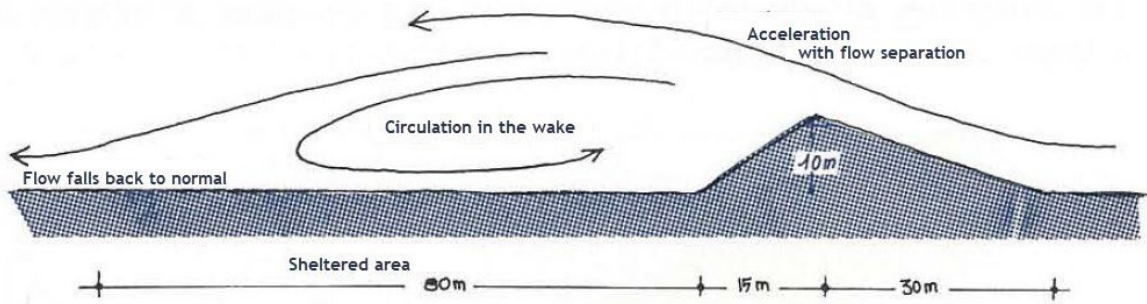

Figure 54 Diagram showing the minimum dimensions for springboard slope to redirect wind flow over an area downwind

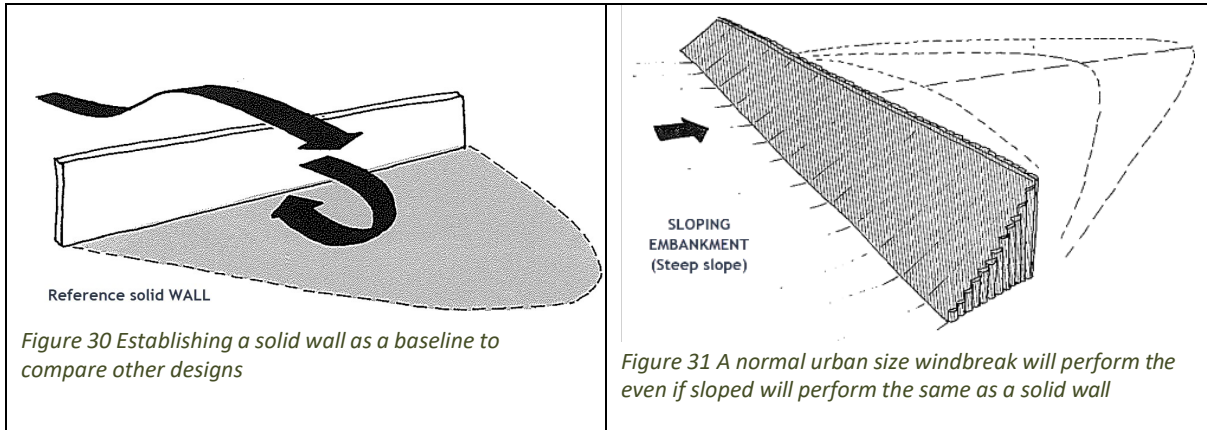

Figure 55 Protection of the boarding quay at Le Havre: concrete springboard ($h = 20\text{ m}$, length = 240m) – if this was solid, it is large enough to redirect wind flows

Urban windbreaks, screens or windbreak structures (except for vegetation, in some cases) typically have a negligible thickness compared to the dimensions wind gusts and therefore the guiding or redirection effect does not occur. Therefore, the flow crosses the windbreak without "sliding" over the obstacle and the general shape of the wind flow is practically independent of the windbreak form.

This phenomenon is even more evident when the windbreak is porous, allowing flow to pass through.

Taking the area of shelter behind a solid windbreak as a baseline, we can compare other design options.



Profiled tops or concave curvatures of the windbreak tend to reduce the protected area (Figure 58). Consequently (in this range of dimensions), the solid or porous flat windbreak is normally the best shape to adopt, since it is simple to use and the required "thickness" is small.

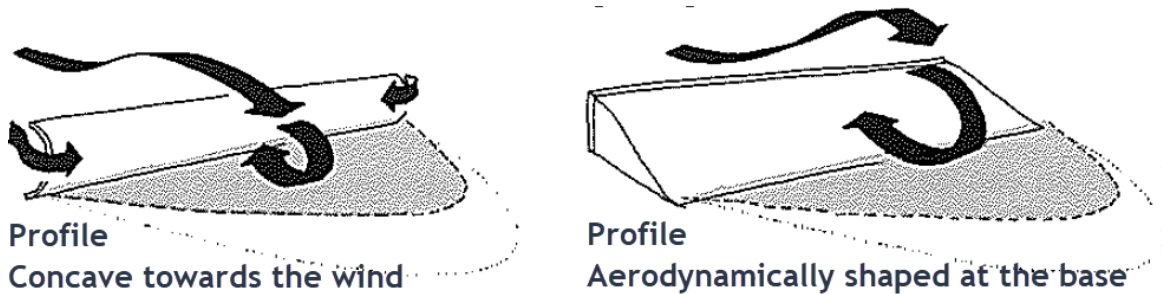

Figure 58 The shaded area behind the concave and aerodynamically shaped windbreaks have the same level of protection as the much larger area defined by the dotted line for the baseline windbreak of the same length and height.

8.5 Dimensions of a windbreak

The transverse dimensions of a windbreak (height and length) are critical to the sheltered area (in particular they affect the sheltered areas S_2 and S_3). The mechanisms for affecting the wake of the screens will be different according to the windbreak dimensions (especially the length L) compared to the transverse scales of the wind gusts. Consequently, the geometry and the area S of a given protection level P will be affected by changes in the height and length of the windbreak.

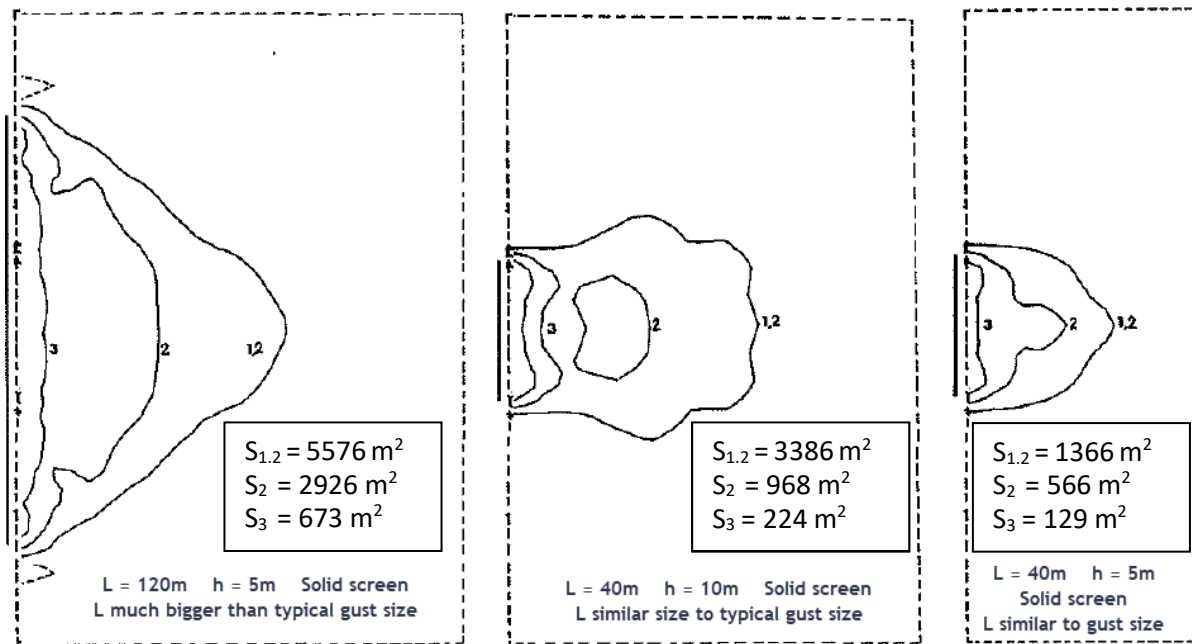
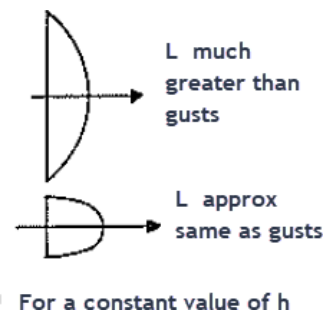

Figure 59 The protected area geometries for different lengths of a solid wall

The length of a windbreak, which (in the Gendemer study) is at least the same order as the transverse scale of the wind gusts, plays a more important role than the height, which is almost always much smaller than the vertical scale of wind gusts. The geometry of protected areas can roughly be linked to a half-ellipse with a major axis formed by the windbreak when the length (L) is much bigger than the transverse gust size; and a half-ellipse with its minor axis formed by the windbreak when the length (L) is similar in size to the transverse gust size. This difference in shelter with different height-length ratios is explained by a greater influence of the flow around the ends of the windbreak end where the transverse wind gust is similar in size to the length (L).



This difference in geometry fades as soon as the solidity of the windbreak “disappears” in front of the wind, particularly when the porosity of the screen increases.

The following estimates apply to windbreaks, in the range of length going from 20 m to 120 m, for the height range between 2.5 m and 10 m and for screens whose porosity is less than 50%:

- The area S_3 , where the wind speed is one third of the incident wind, is proportional to $L^{1.5}$
- The area S_2 , where the wind speed is halved, is proportional to $L^{1.3} \cdot h^{0.7}$
- The area $S_{1,2}$, where the wind speed reduces by 20%, is proportional to $L \cdot h^{0.6}$

Given the influence of the porosity, the immediate wake area S_3 where a high level of shelter occurs is not significantly dependent on the height of the windbreak. In the case of a solid wall where its length L equals the transverse gust size, the area S_3 is proportional to the wall height, h.

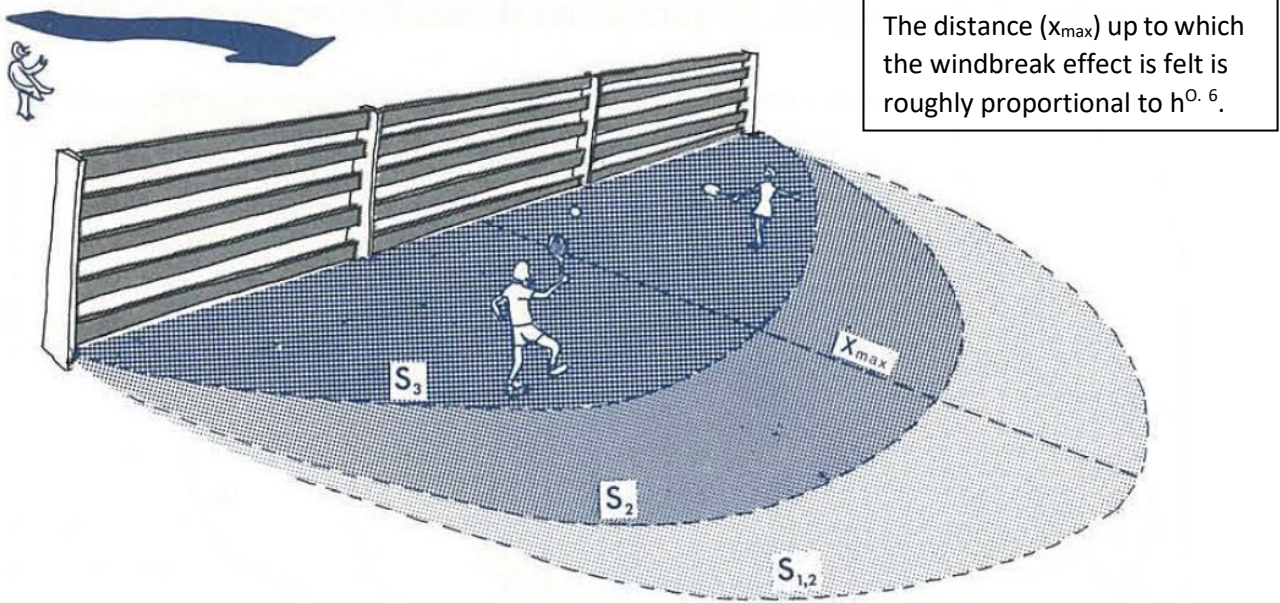
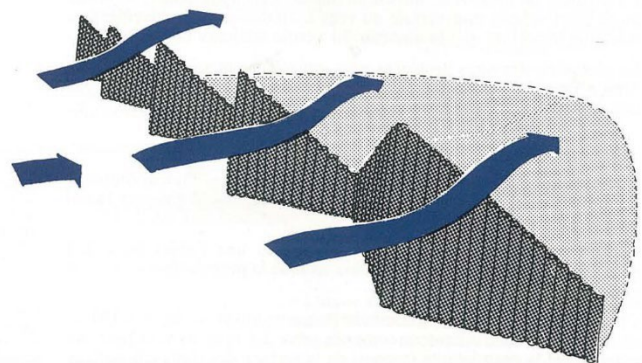

Figure 60: Areas of protection downstream of a wind break

From a practical point of view, keeping in mind the importance of height and length on the protective effect, the efficiency of a solid flat wall can be improved by varying its height and planform layout in a zig-zag fashion, as illustrated. This geometry introduces a three-dimensional wind mixing/dispersion, and provides better protection in the wake.



Protected areas (S) are increased compared to a solid wall with dimensions $h = 5$ and $L = 120$ m by about 10% for zig-zag height between $3.5 \text{ m} < h < 6.5 \text{ m}$ and planform steps spaced approximately $5 \text{ m} < l < 20 \text{ m}$.

8.6 Permeability of a thin flat windbreak

The geometric porosity used to characterize the permeability of windbreaks is defined as:

$$\Phi = \frac{\text{area of holes}}{\text{total area}}$$

The geometric porosity Φ does not fully describe the characteristics of windbreaks, in that two windbreaks of the same porosity may affect the air flow which passes through them differently depending on the dimensions of the holes, their shape (nozzle) and the type of materials used (different internal roughness for example). Likewise, plants or hedges that look solid to the eye will produce a wake that is very different from a solid wall.

Aerodynamically, it becomes necessary to introduce the concepts of pressure drop or force drag, which can be measured in a wind tunnel, but are very difficult to apply in practice. Given practical constraints (type of materials, aesthetics, etc.) the simple notion of geometric porosity is used to describe windbreaks here after.

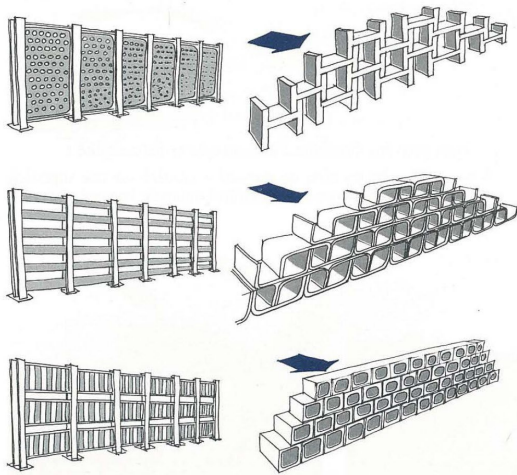

Figure 61 Examples of permeable screens (variable geometric porosity)

The porosity of a screen introduces another variable in the protective effect of a windbreak (with reference to a solid wall).

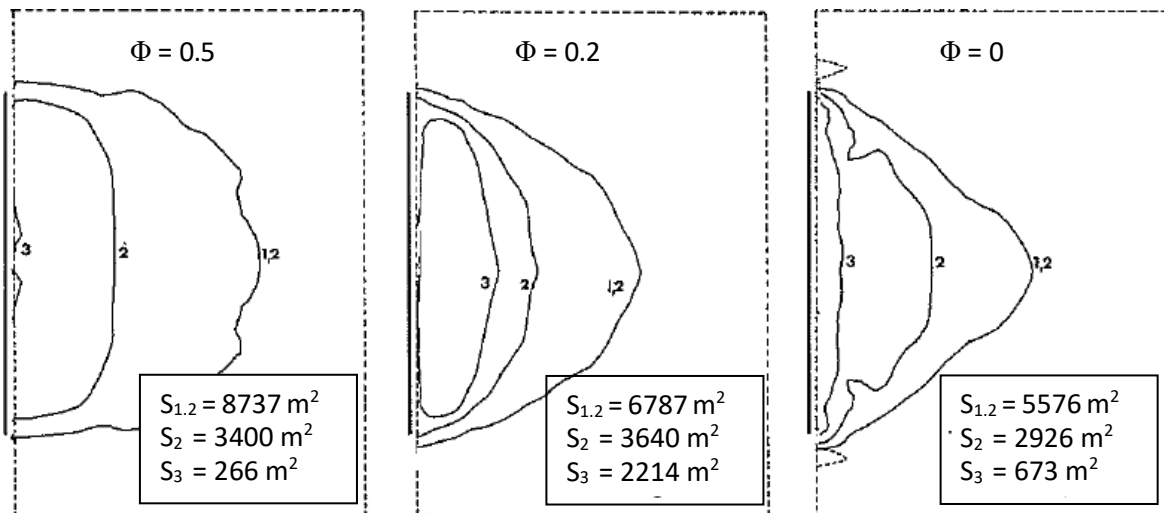

Figure 62 Protected areas (S) behind porous screens in an open country wind profile ($h = 5$ m and $L = 120$ m) (reference: solid wall $\Phi = 0$)

We can quantify the shelter by adjusting ‘porosity’ as follows:

- If you are looking for a moderate protective effect over the greatest possible area (as measured by the 20% improvement Protection Factor of 1.2) the optimal geometric porosity is approximately $\Phi = 0.5$ (e.g. large areas of crops protected somewhat).
- For better protection (sheltered areas corresponding to either Protection Factor S_2 or S_3), the optimal geometric porosity (leading to a maximum protected area) is $\Phi = 0.25$.
- When the porosity $\Phi = 0.7$ high protection areas no longer exist (S_3 is essentially zero).
- In the case of screens with a non-uniform porosity distribution, the permeability at the bottom of the screen directly affects the level of protection in the near wake (from 0 to 10 times the height h downwind).

- Placing the porosity only in the lower third of the windbreak wall achieves similar sheltered area in the wake for Protection Factor S_2 and $S_{1.2}$, but removes the highest level of protection S_3 (see *Figure 63*).
- Distributing the porosity unevenly with larger gaps at the bottom of a screen gives more ventilation of the wake at the bottom. This asymmetry always produces a gain in the area of the wake sheltered at level $S_{1.2}$ compared to uniformly distributed porosity for the same average geometric porosity. The flip-side is that the areas protected at levels S_3 and S_2 are smaller (*Figure 64*).
- Distributing the porosity unevenly with smaller gaps at the bottom of a screen produces a systematic reduction of the area $S_{1.2}$ compared to a screen with uniformly distributed porosity.

Applying a variable distribution of geometric porosity in practice requires an aerodynamic “finesse”, making it prudent in most cases to use a homogeneous distribution.

8.6.1 Practicalities of the concept of porosity

The notion of geometric porosity is unambiguous for thin screens such as perforated sheet, nets, wire mesh, etc. It is advisable, however, to ensure the holes have a diameter greater than a few millimeters.

- For materials of a given thickness, additional dissipation occurs inside the orifice so the effective size of the holes is reduced. The porosity must not consist of too many small holes/gaps or the porosity will depend more on the thickness of the material. In general, the definition of geometric porosity will keep its physical meaning as long as the thickness of the material remains less than 3 times the diameter of the hole/gap.
- In the case of a thick structure where the orifices have a depth greater than 6 times the diameter of the hole, the effective porosity is 60% of the geometric porosity.
- For a given overall porosity, the distribution of the orifices must be as homogeneous as possible. For user comfort, it is advisable to choose the diameter of the orifices in the range 2 cm to 15 cm, with the limits on thickness already mentioned.
- Specialist advice will be needed to determine the effective porosity of holes, where the axis of the hole is not horizontal.

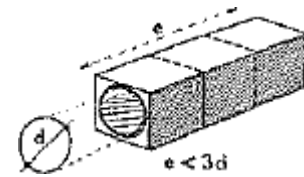

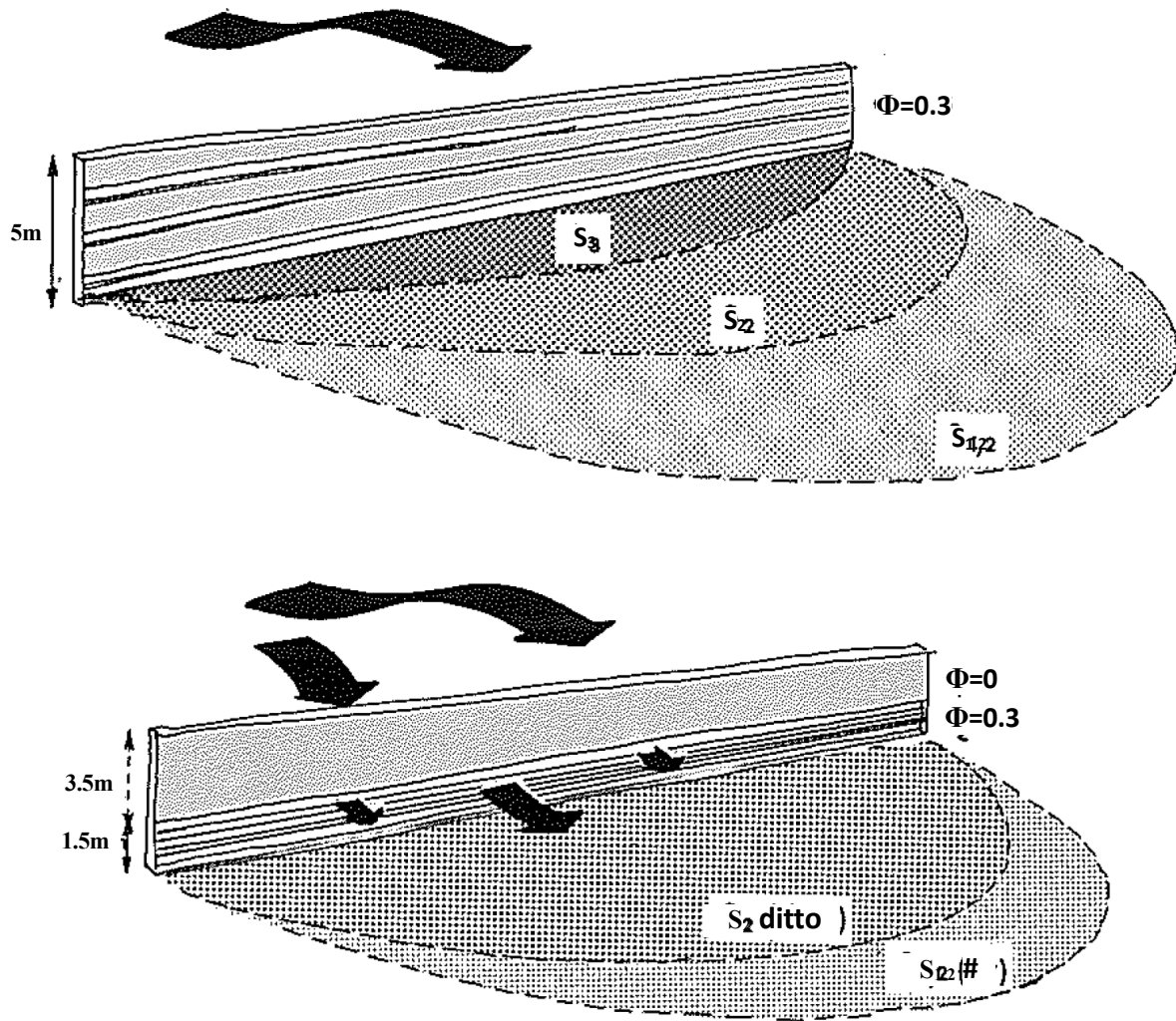

Figure 63 Placing the porosity at the base of a wall, rather than distributed homogeneously removes the Protection Factor 3 shelter, but retains a similar area sheltered at Protection Factor 2, and 1.2

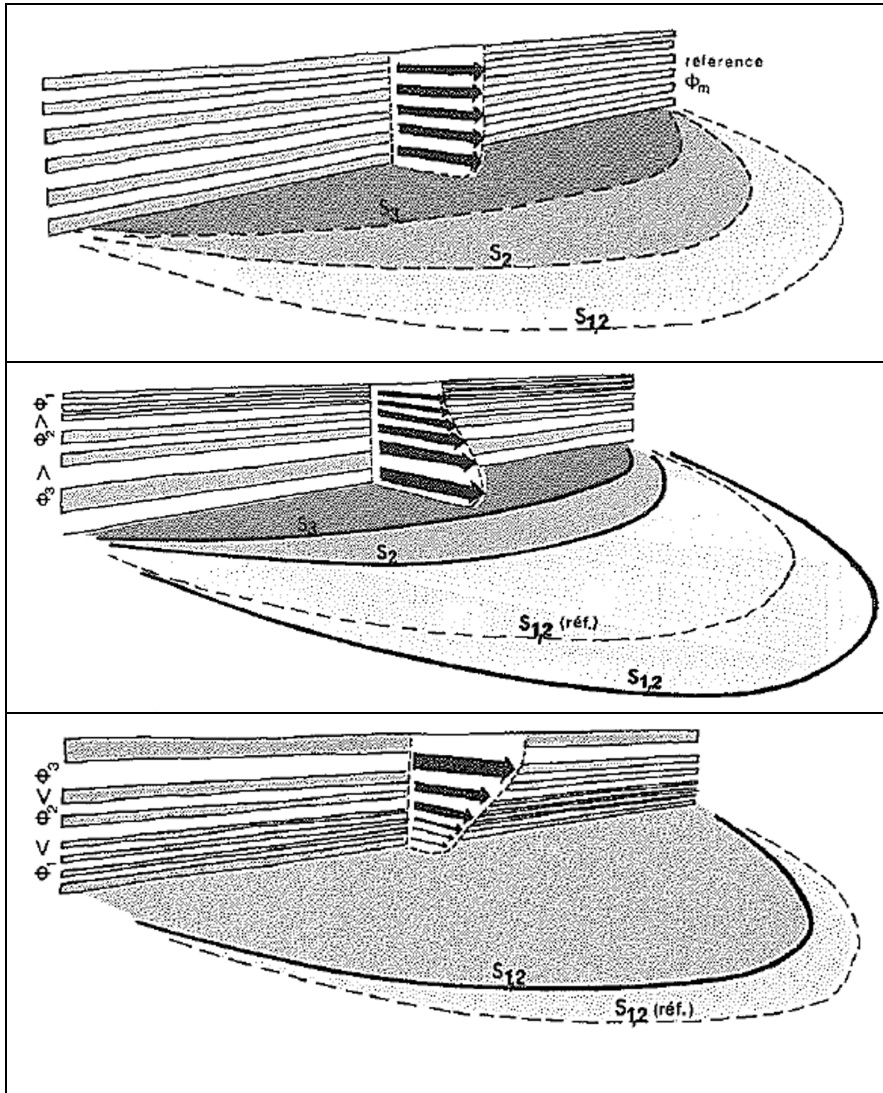

Figure 64 Asymmetrical distribution of porosity affects the area sheltered in a complex manner

8.7 Treatment of the ends of windbreaks

The strong horizontal variation in speed (horizontal speed gradient) at the end of the screens associated with the increased speed of the flow around the corners (more important as the porosity reduces) are particularly uncomfortable and also produce two downstream corner eddies that locally reduce part of the protective effect.

The following treatments are possible:

8.7.1 Practical advice for solid windbreaks

Careful design of solid windbreaks, which at their centre can provide a reduction of wind speed by a factor of 3, can be improved by modifying the flow around their ends where the accelerations are worst.

- A stairway end configuration gives protection identical to that obtained with a solid windbreak, of equal length with an abrupt end discontinuity. At the same time, the strong horizontal gradient of speed disappears as well as increased speed around the corner.

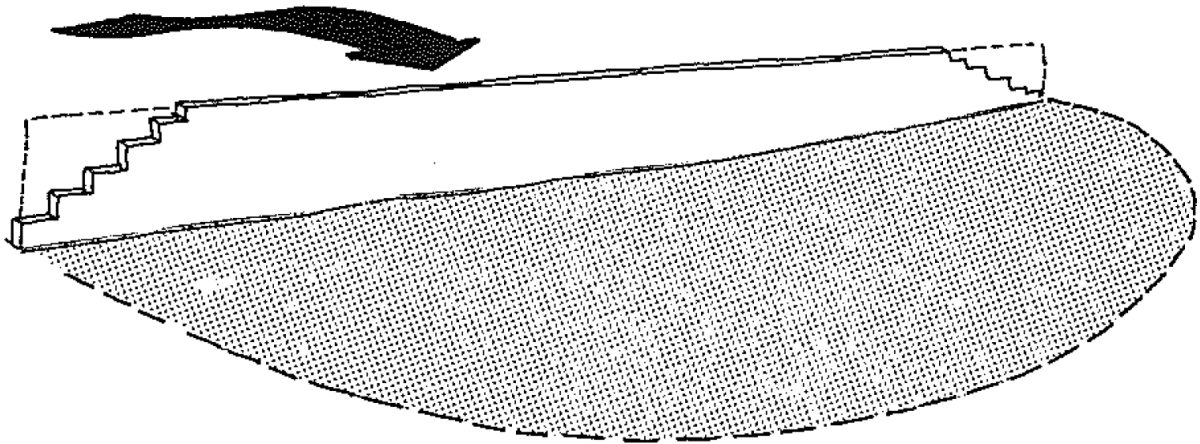

Figure 65 Identical areas of protection at all levels for the two windbreak geometries

- Increasing the porosity gradually over the last 10m meters before the end (e.g. $\Phi = 0.2$ to 0.5) eliminates the corner/end anomaly and produces an overall increase in areas $S_{1,2}$, S_2 and S_3 of the order of 25%.

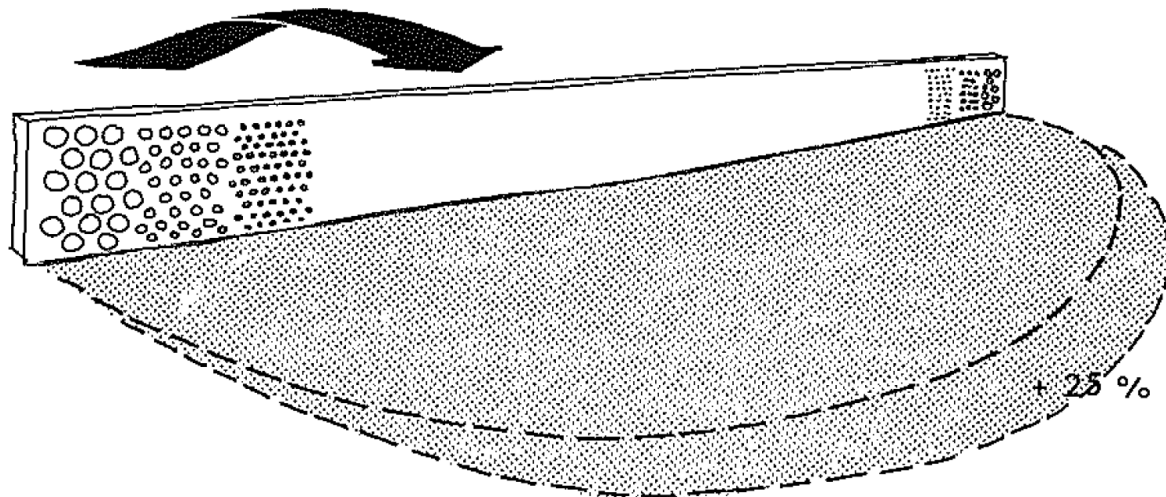

Figure 32 25% Increase in area of protection at all levels compared to a solid screen of the same dimensions

8.7.2 Practical advice for porous windbreaks

Porous screens can also be detailed to improve their functionality.

- For a screen of porosity $\Phi > 0.20$, the end effects no longer exist.
- For screens where porosity is $\Phi \geq 0.20$, adding two porous “cheeks” ($\Phi = 0.2$, about 10m long) at right angles to the screen, reduces the corner anomaly and induces a significant gain in the area protected, producing an increase of 25% in $S_{1,2}$, 15% on S_2 and 25% on S_3 .

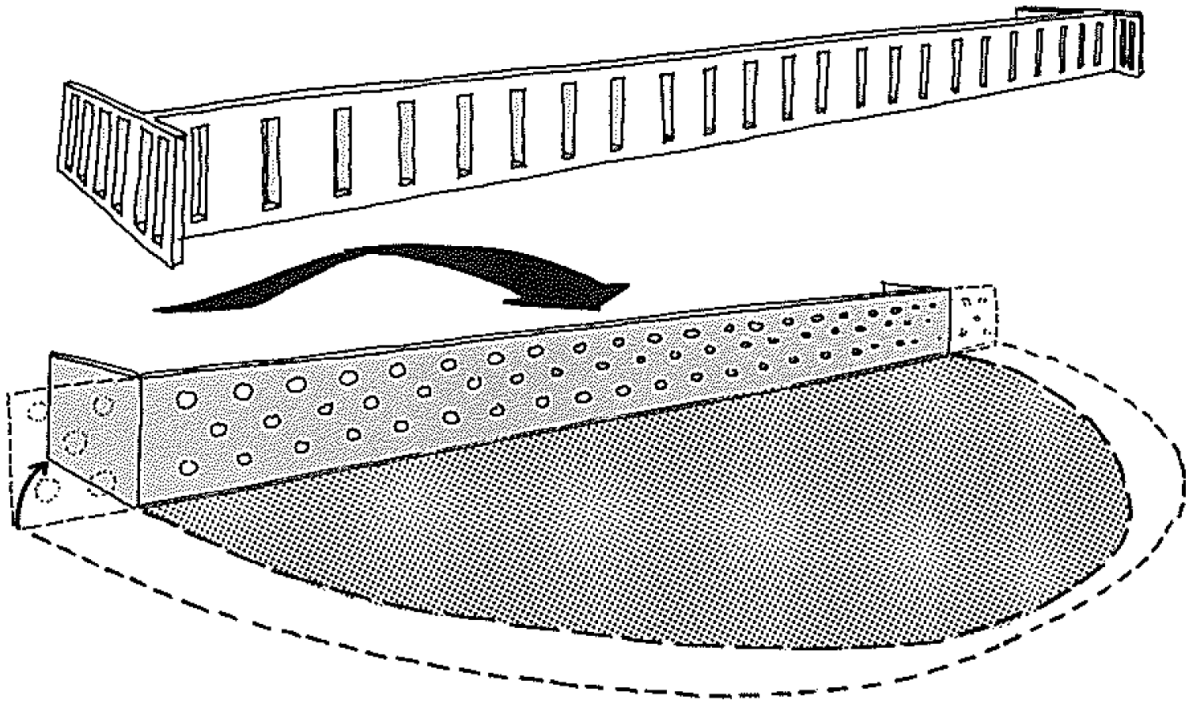

Figure 33 On an equal line, the protection is lower with both cheeks

The use of porous cheeks in the case of solid wall leads to identical gains at all levels of protection on the areas protected and eliminates the corner anomaly.

The addition of solid cheeks for porous screens improves the protected areas by approximately 10 to 15% but reinforces the corner anomaly at the ends.

For an equal linear length and for a permeability $\Phi = 0.2$, a screen with two 10m 'cheeks' has a worse area protected than a screen that does not have cheeks.

In practice, it is advisable to eliminate the discontinuity at either end of a screen by using combinations of stepped ends or increasing porosity. This will eliminate the corner anomaly. In addition, for permeability screens $\Phi \leq 0.2$, the addition of permeable elements aligned with the wind direction systematically improves the protective effect.

Landscaping and vegetation can also be used to treat the ends of a screen.

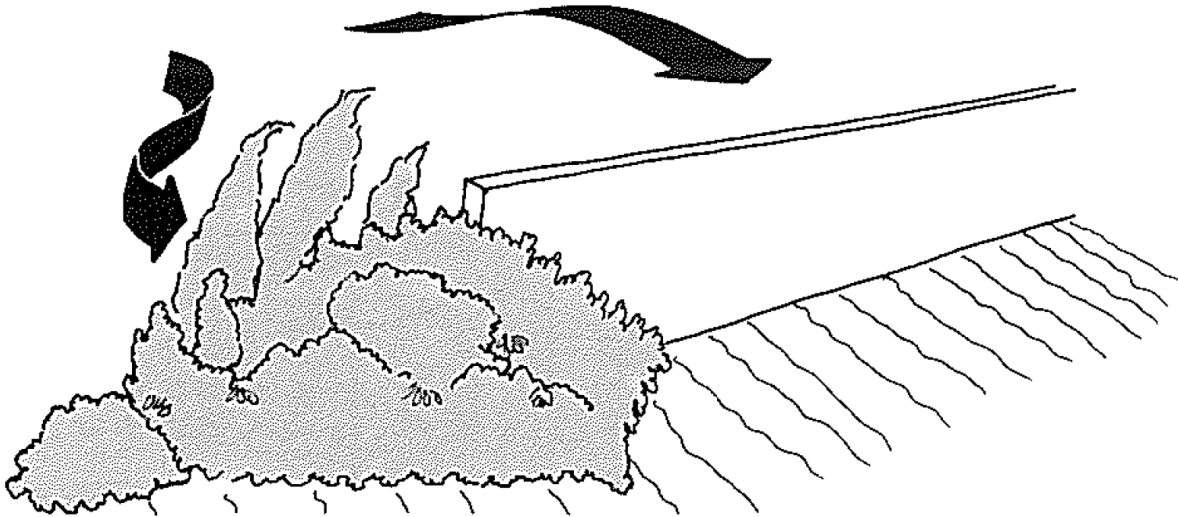

Figure 34 If the plants can grow in the extreme winds at the ends of solid windbreaks, they can provide the necessary porous transition to improve the overall function of the windbreak

8.8 Examples of combinations of aerodynamic elements

8.8.1 Springboard with windbreak on top

When the dimensions are sufficiently large (height 10 to 15 m, windward slope 3/1 and leeward slope 2/1), the springboard effect can work.

If we compare the protection behind a springboard 10 m high with a ridge whose crest is sawtooth (height between 8 and 12 m) with a distance between the peaks of 30 to 40m and with partial obstruction (about 50%) in the hollow parts at the top (windbreak of $\Phi = 0.5$ for example), there is a gain in the area (S_2) of protection where the wind speed is halved of more than 50%.

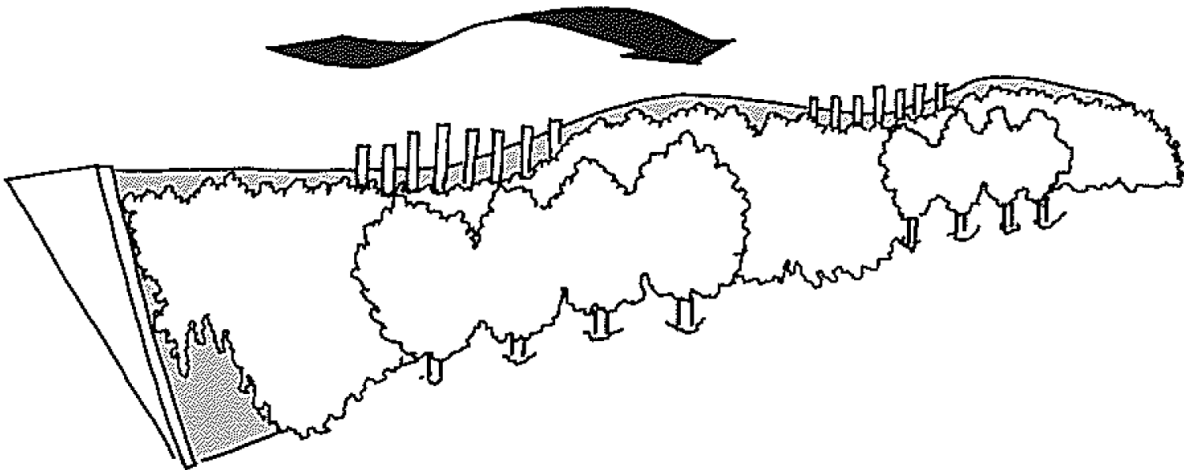

Figure 69 The area where the windspeed is halved is doubled by comparison with a simple springboard shape

This embankment architecture combines a major springboard effect and an auxiliary dissipation effect: the three-dimensional flow past the ridge (pyramid) creates accelerated flow that is dissipated by the partial obstructions. In practice, these obstructions can be created with piles, logs, rockeries and vegetation and should always be placed slightly downwind of the ridge.

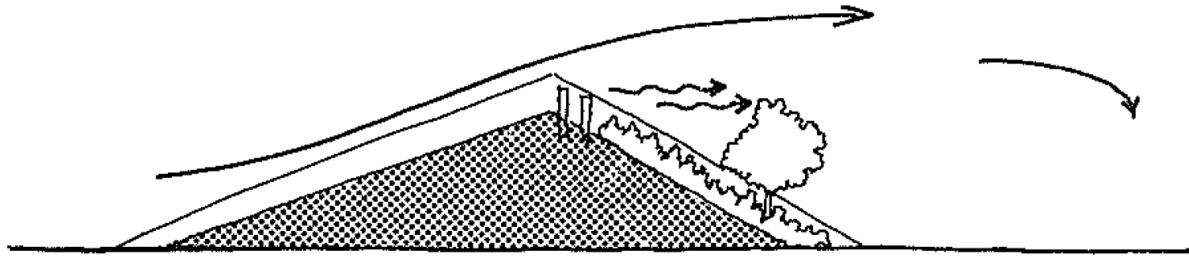

Figure 70 Wind redirection "springboard" with landscape elements that double the area of protection

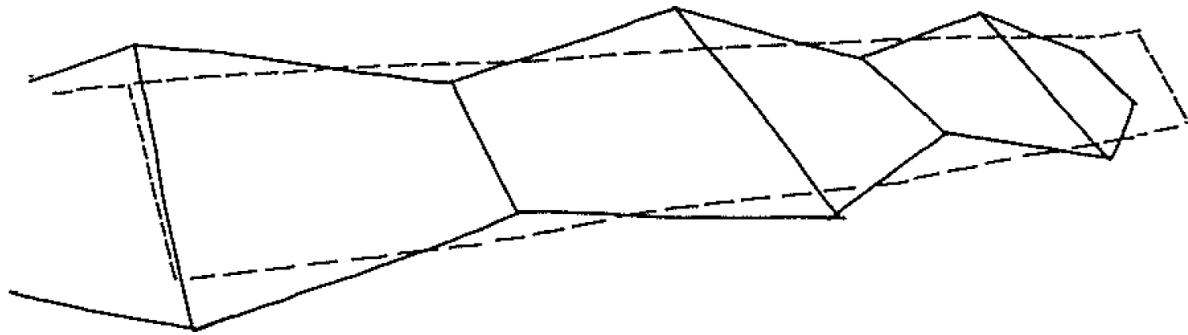

Figure 71 The crest step must be less than 40 m if it is to be "seen" by the wind.

8.9 Aerodynamic efficacy of planted windbreaks

Geometric porosity has been shown to have a preponderant role in the protective effect of windbreaks. For planted windbreaks, the porosity is a function of:

- The flexibility of the branches, the orientation of the foliage, etc. (this will vary with the wind speed and as a result vary from one moment to another).
- Depending on the foliage of a shrub or hedge, the "filtering" provided by the leaves may not be equivalent.
- The amount of foliage at ground level, or not, which may result in a large porosity at the base due to open spaces between the trunks at the base of the foliage.
- The season will affect the protection behind deciduous foliage, which will become non-existent.

When the effective geometric porosity of trees and hedges is the same as the artificial screens previously discussed, planted trees and hedges provide equal shelter to that behind the artificial screens. Therefore, the parameters that describe the protection downstream of trees and hedges are:

- the linear (Length, L and height, h) dimensions of "the planted obstacle";
- the "visual porosity" (visual percentage of the screen that is open); and
- the overall form.

The porosity of a hedge depends on the nature of the plant, its composition and thickness. Although the "visual porosity" is somewhat subjective and schematic, it allows the protective effect against the wind to be classified simply:

- Hedges whose percentage of "visual porosity" is practically zero behave like an artificial thin screen of the same dimension (L, h) and a geometric porosity $\Phi = 0.2$. The protected areas

are the same. This is the typical case of conifers (pruned or not) in a dense strip (tight planting), such as cedar and cypress.

- Protection over a greater distance can be achieved with underplanting. For example, a cypress windbreak with clumps of plants at their base (creepers for example).
- Hedges with a visual porosity of approximately $1/3$ (forms can be identified through the planted obstacle), will give protection identical to that of a thin screen of geometric porosity $\Phi = 0.5$.
- Hedges whose visual porosity is of the order of 50 to 60% provide much less shelter downstream. It is estimated that such a hedge has the protective efficiency of a thin screen of geometric porosity $\Phi = 0.7$. For example, the majority of deciduous hedges in winter have this porosity.
- For visual porosity greater than $\Phi = 0.7$, hedges provide no wind protection.

A problem of windbreaks that comprise a screen of trees is that the base, around the tree-trunks can be completely open. In the case of dense leafy foliage, ventilation at the base may even introduce an acceleration of the flow over the entire height of the open trunk and which extends over a distance of 1 to 2 times the height downwind. For example, a curtain of maples (high trunk) or pines will have zero protection at their bases.

If the windbreak is formed from large trees that emerge from dense bush or a natural hedge, the homogeneity of the texture is consistent and the classifications based on visual permeability will be relevant. Thus, for an estimated "average" height and visual porosity, it will be possible to estimate the protection level ($S_{1.2}$, S_2 et S_3) behind a screen of trees of length L .

Sticks or saplings of cherry trees, chestnut trees and oaks (visual porosity $1/3$ and corresponding geometric porosity $\Phi = 0.5$) have a protective effect over a larger area (particularly in the distant wake) than more opaque foliage such as leafy curtains of ash and elms or cypress (zero visual permeability and corresponding geometric porosity $\Phi = 0.2$). On the other hand, the more opaque foliage offer a higher level of protection in their immediate wake.

8.9.1 Wooded strips (thickness about 20 m)

The protection provided by woody strips whose base, or undergrowth, is trimmed (bush, regrowth, etc.) and thickness of at least 15 m constitutes an almost ideal windbreak:

Close to the wooded strip, in the wake there are very high levels of protection ($P = 2$ and 3) while far downstream a protection effect ($P = 1.2$) persists (beyond 200 m for a wooded area about 10 m thick). Furthermore, wooded strips of thickness greater than 20 m have a similar behaviour.

The minimum area of protection downstream of a wooded strip (natural constitution of oaks, beeches, etc., with coppice on the ground) or of a forest (height h , and length L) can be estimated by using a porosity of $\Phi = 0.25$ in the calculation for the level of protection $P = 2$, and a porosity of corresponding to $\Phi = 0.5$ for a level of protection $P = 1.2$.

Finally, an open space with a radius of 100 m surrounded by a wooded crown (height $h = 10$ m and a thickness of 20 m) will have a level of protection higher than $P = 2$ over its whole area.

8.9.2 Composition of the planted screen – practical aerodynamic advice

A wide variety of plants, shrubs and trees can be used to create windbreaks. Climate and practical constraints of implementation will be the preponderant parameters, provided the following aerodynamic principles are respected:

- Planted screens should be of homogeneous texture. Depending on the species used, a variety of vegetation will be necessary, especially around the foot of shrubs or trees.
- Optimal porosity corresponds to visual porosity that is zero (high immediate protection, widely used in the vicinity of dwellings) or low (larger-scale protection, used in rural areas). Consequently, the foliage of planted screens should be dense. This density is a function of the species but also of the thickness which is planted and the relative arrangement of the plants (staggered, parallel rows). A landscaper or the horticultural engineer will be able to advise the best choices for specific applications.
- Optimal efficiency is obtained, as in the case of artificial screens, for an orthogonal incidence. During the establishment of the plants, a wind shield will have to be installed to allow the growth of the plant screen. This shield can be made, for example, of mounding of earth, rockeries or robust creeping plants.
- The combinations of planted screens works in a similar way to artificial screens:
 - Courtyards formed by a planted hedges (height about 3 m) of 10 m radius will provide a particularly protected microclimate protection $P = 3$ (for all wind directions).
 - The combination of two hedges with a visual porosity of 0.3 and spaced approximately one times their height apart leads to a protective effect greater than what could be obtained with a single hedge (of the same height) that is opaque to the eye.

8.9.3 Implementation constraints

The fundamental difficulty using plants to control microclimatic environments are their living nature! It is therefore advisable to ensure some precautions are taken when plants are used as a "windbreak".

To guarantee effective protection against the wind, it will be necessary to ensure the proper conditions for the growth of the plant screen. The richness of the soil and water supply will determine the success of planted windbreaks, and the maintenance and upkeep of the plants will have to be taken into account.

Planted windbreaks require the following factors (including the aerodynamic concepts in the preceding paragraphs) to be considered:

- the degree of exposure to the wind: depending on the climatic characteristics of the region or the topography of the site, strong exposure by the sea or on a crest makes the development of the vegetation difficult, while in the open area at the foot of a hill the atmosphere will be much more favourable.

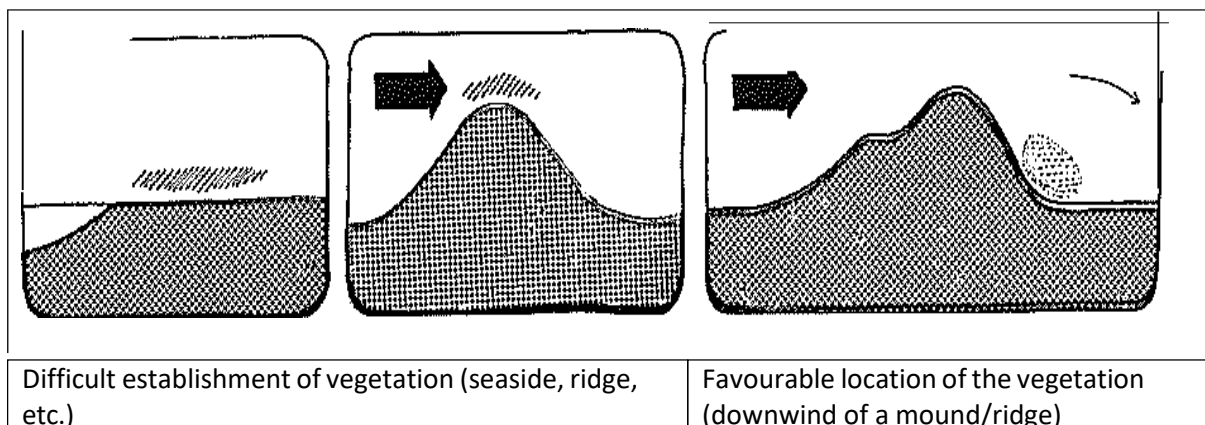

- In exposed areas, it will be necessary to use resistant species, and appropriate use of the plant that develops naturally on the site will help to solve the problem.
- By the sea, the aggression of salt spray complicates the implementation. In some cases, it will be necessary to provide for washing the leaves to remove some of the corrosion of the salt.

Mesh screens can be used temporarily or permanently (*Figure 72*) to ensure good growth until tress mature.

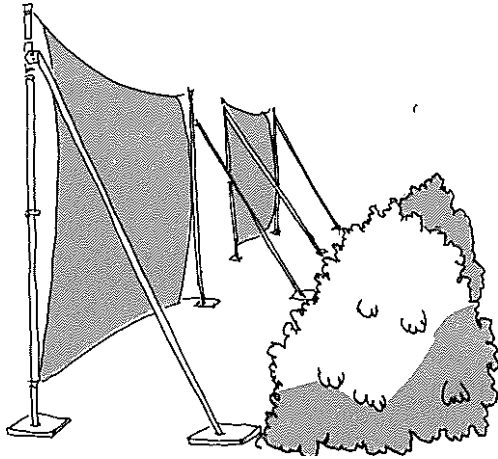

Figure 72 Use of stretched mesh as temporary windbreaks



Figure 73 Wind hardy plants with permanent metal mesh screens enabling them to grow (somewhat) in salt spray zone at the seaside

In the area exposed to the wind, the morphology of the vegetation can dictate the choice of species and contribute to the chances of development of the planted screen.

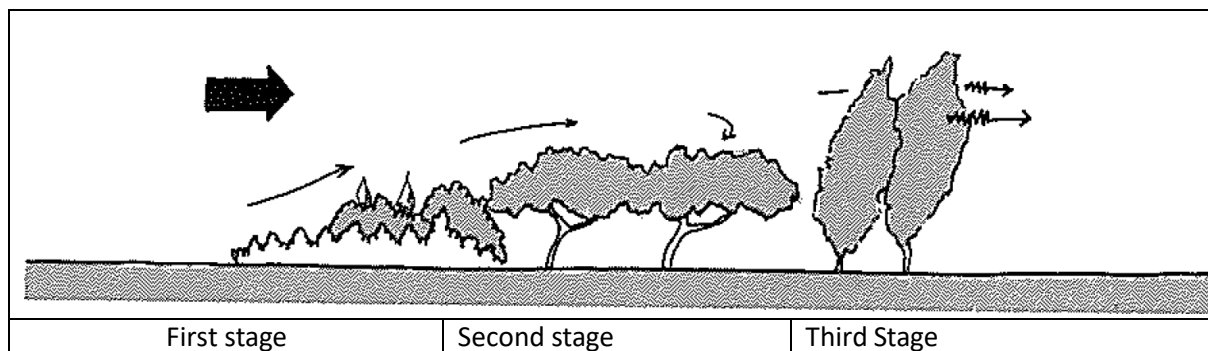

Figure 74: Stages for planted screens

A first, relatively low stage, consisting of creeping, bushy or shrubby plants, ensures “shield” protection at the level of pedestrians (cotoneaster, pittosporum, laurel, etc.).

A second stage of medium height, serving as a cover, continues the protective effect. It prevents the wind flowing back to ground level; the base can be open since it is protected by the first stage. A ball or spread vegetation can be adopted (umbrella pine, cork oak, etc.).

The third higher stage serves as a sieve and extends (depending on the height in particular) the protective effect. Erect (poplar) or conical plants are recommended.

8.9.4 The composition of the soil (natural or added) and its water supply

The chemical composition of soil directly affects the growth and development of plant species: for example, for a lime soil, the Provencal Cypress and the Judas tree are perfectly adapted; on the other hand, the bald cypress and the country elm will likely perish.

Therefore, during the implementation of vegetation, it is important to get advice from a horticulturalist.

Water availability for the plants will also need to be reported. For example, 20m³ of earth (height 1m, length 10m and width 2m) requires about 10,000 L of water per year if for a grouping of privet, cedar or cypress to grow.

The groupings of plants can also be successfully carried out in pots, in containers, on slabs and embankments.

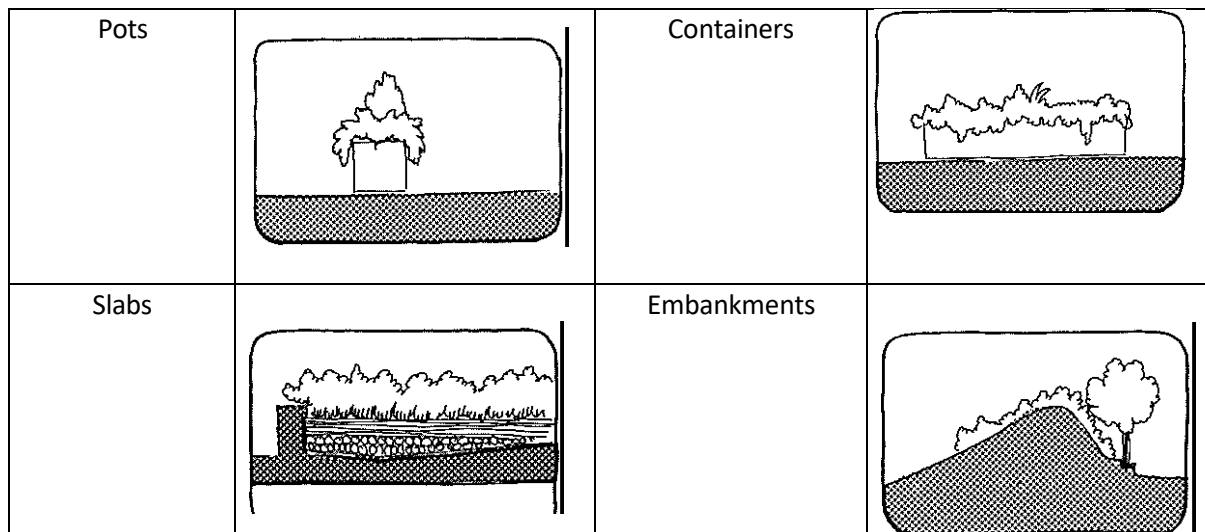

Figure 75: Showing potential vegetation placement

In all cases (natural or added soil), the volume of growing soil must be related to the plant volume. Thus, for plantings on slabs, a few tens of centimetres are enough for a low vegetation, but for groups of plants of medium height (a few metres), a minimum of 0.8 m of soil thickness must be provided.

This type of development poses the problem of overload caused especially in rainy weather where the weight of the water is added to that of the earth. In addition, it is necessary to provide for effective drainage to compensate for the disturbances linked to drainage.

The protection from planted windbreaks is increased when combined with other aerodynamic interventions (earth mounding, rockeries, artificial screens, etc.).

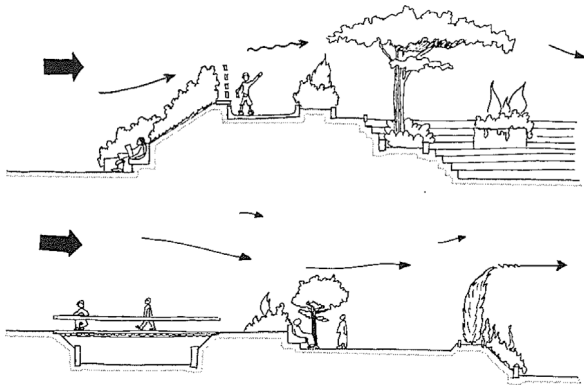

Figure 76 Examples of associations of earth mounding and planting

In addition, the richness of its other bioclimatic qualities: creation of shade (summer) and determination of light, limitation of the heating of surfaces, humidification and air purification, soil fixation and erosion control, visual privacy, etc., often make plants a preferred treatment element for outdoor spaces, if they can be supported to grow against the wind.

8.10 Constraints and implementation of artificial screens

In addition to its protective role for which it is designed, artificial windbreaks must be strong enough to resist the wind loads. For important work it is advisable to call on a design office.

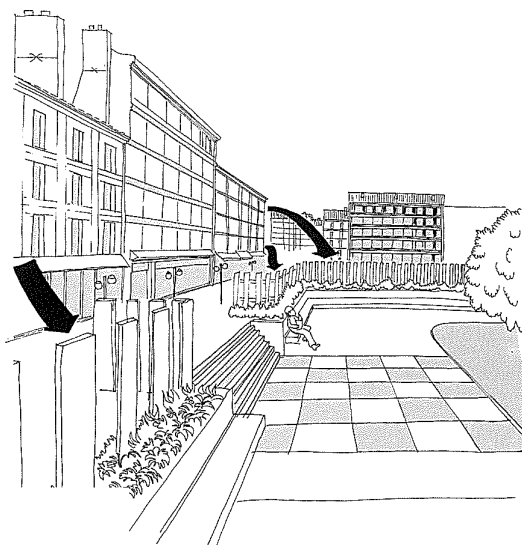

Figure 77 Example of integration of windbreaks into an urban environment

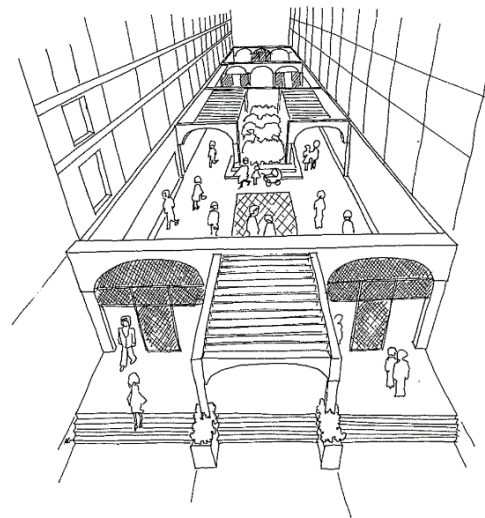

Figure 78 Constructed windbreaks in an urban environment

Like plants, an artificial wind break is part of our environment. Therefore, an aesthetic and visual interpretation will have to be found. Integration into the landscape will depend in part on the consultation between landscaper, architect and aerodynamicist.

8.10.1 Practical Advice

A windbreak, by its presence, modifies the framework of its location. One way to successfully integrate it is to make it play one or more complementary roles. Research on possibilities of

multifunction will improve its integration and even, in some cases, reduce its cost. Examples of dual functions are:

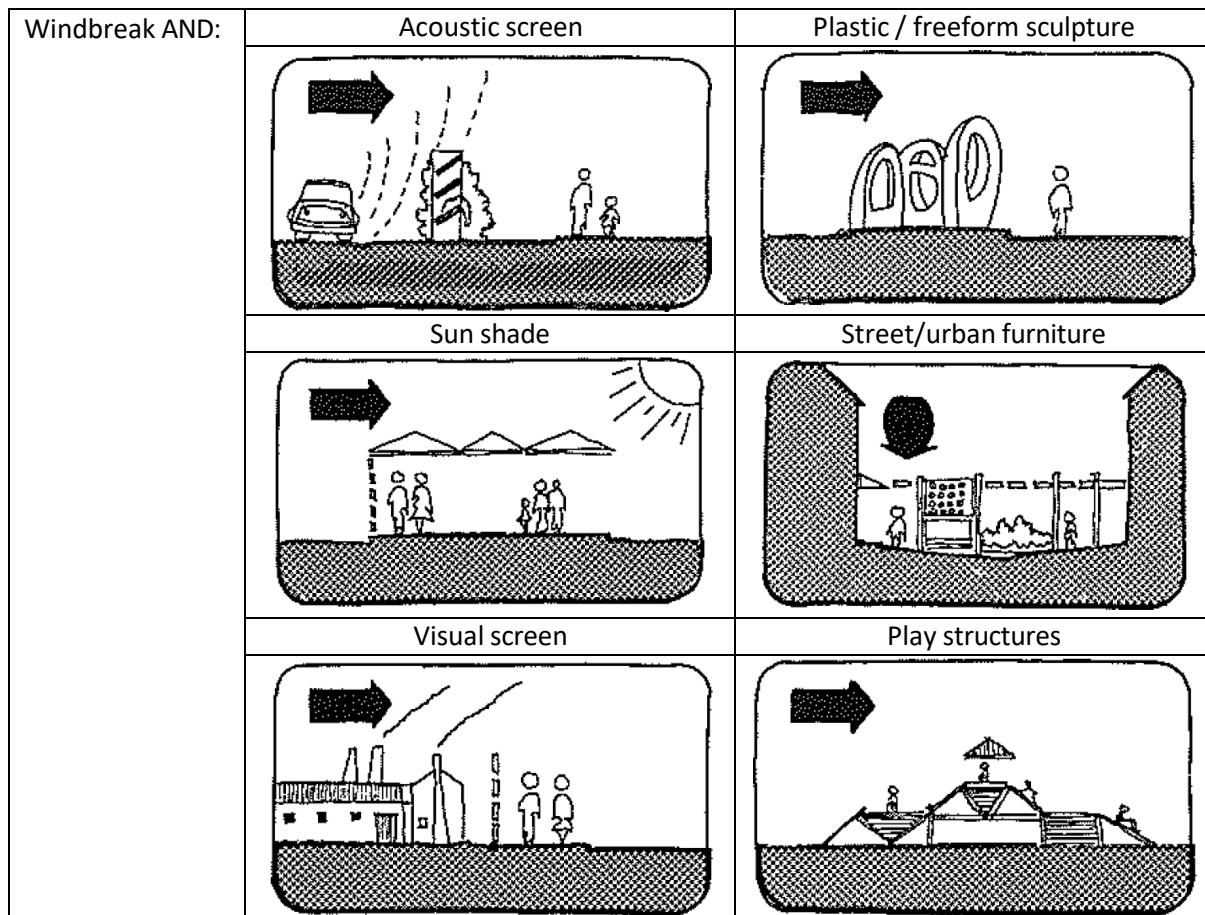

Figure 79: Wind breaks with dual function

When windbreak structures are built, other nuisances should be avoided: for example, acoustically, the use of materials such as brick, concrete or such as wood do not generate aerodynamic noise. On the other hand, light structures made of metal can introduce whistles (small elements forming a link between panels, or parasitic vibration of sheets or blades lacking rigidity).

Too much shelter should not be created to the extent that, on windless days, problems of air renewal and pollution arise. It will be necessary, for example, to preserve in the climatic development of a space, "ventilation", well positioned, which will allow a light circulation of air; again, the support of technical specialists can only be beneficial.

9.0 Conclusion

This guide is intended to provide architects, landscapers, planners and developers with information to help them understand the interaction of buildings and the wind and to control wind accelerations in outdoor areas. More generally, its aim is to enable designers to have means to design for protection against the wind.

The effectiveness of aerodynamic principles and corresponding devices is quantified according to their context of application and as far as possible general guidance has been provided in the form of many practical tips. Nevertheless, we advise designers to consult environmental aerodynamicists, especially in regard to microclimatic control in urban areas. Specific wind tunnel studies of design ideas sparked by this guide will prove a more reliable prediction suited to the specific urban context and will often be essential.

It must be remembered that the quality of outdoor spaces is a combination of all the environmental factors affected by buildings and wind shelter devices like windbreaks. Buildings can create unwelcome or useful shade impacts on outdoor spaces depending on the season or the local climate. In addition to the aerodynamic action of windbreaks, they can possess other functions such as acoustic screen, sand trap, space definition, etc. Above all windbreaks must be integrated into a specific local environment.

Consequently, far from weighing down the design of buildings or additions and alterations to existing buildings with constraints, the goal has been to identify how groups of buildings and windbreaks can support a new architectural expression, a Bioclimatic Urbanism. A goal of this guide is to contribute to freeing the architect from the environment in this way.

Appendix 16: City Outcomes Contribution

This appendix and the requirements set out within it apply to the City Centre Zone, Metropolitan Centre Zone and Local Centre Zone, and relates to and should be read in conjunction with District Plan provisions CCZ-P11, MCZ-P10, LCZ-P10, CCZ-R19, CCZ-R20, MCZ-R20, LCZ-R18, and CCZ-S1.

City Outcomes Contribution is a method that aims to ensure 'density is done well'. It is a method to ensure that tall buildings (relevant to zone typologies) and buildings under the City Centre Zone minimum building height provide beneficial public and private outcomes, as identified in Table 3 below, and contribute to well-functioning urban environments.

It is targeted at commercial, residential and mixed-use developments that are either under-height or above area specific height thresholds. These developments, typically more so than others, have the potential to impact on the quality and level of public and private amenity within the City's commercial centres, and securing additional benefits from these developments is therefore required.

The following development must meet the City Outcomes Contributions requirements:

- Development in the City Centre Zone under the Minimum Building Height control (CCZ-S6);
- Development in the City Centre Zone above the City Outcomes Contribution height thresholds (CCZ-S1); and
- Development in the Metropolitan Centre Zone and Local Centre Zone above the maximum building height limits (MCZ-S1 and LCZ-S1) where these standards are exceeded by 25% or more.

The following tables set out the development types that trigger consideration of **City Outcomes Contribution**, including associated numeric thresholds to be satisfied and the outcomes sought. The thresholds defined in the below tables reflect the extent of the impact certain forms of under-height or large-scale development can have on the city. For example, the taller or larger the development, the greater its potential impact on public amenity and urban living in the city. Consequently, it is anticipated that under-height or larger developments will positively address future challenges confronting the city regarding access to public and green space, sustainability and climate change, accessibility, and assisted housing.

Table 3 identifies how points can be achieved per each outcome in the table. It is recommended that where a development exceeds the City Outcomes Contribution height threshold (CCZ-S1) or maximum building heights (MCZ-S1, LCZ-S1), that developers engage in pre-application discussions with the Council. This will enable the developer to work with the Council to determine whether they can obtain sufficient points to achieve the City Outcomes Contribution prior to lodgement of the resource consent application. As much clarity and certainty has been afforded as possible through this appendix, however, full certainty with regards to points allocation will not be provided until the resource consent application is lodged.

As indicated in the applicable policies (CCZ-P11, MCZ-P10, LCZ-P10), an application needs to provide outcomes from two or more City Outcome Contribution categories.

Table 1: City Centre Zone – City Outcomes Contribution Height Thresholds for any under or over height development

Threshold	Points required	Comments
<u>Maximum City Outcomes Contribution height limit threshold</u>		
Any development that exceeds the maximum height limit by threshold by 10% - 24%	20	Developments that are within the 10% height threshold do not need to meet the outcomes, however they need to satisfy the relevant guidelines in this guide
Any development that exceeds the maximum height limit threshold by 25% - 49%	30	
Any development that exceeds the maximum height limit threshold by 50% or more	40	
<u>Minimum height limit</u>		
Any development below the minimum height limit by 25% - 49%	30	Developments below the 25% minimum height threshold do not need to meet the outcomes, however they need to satisfy the relevant guidelines in this guide.
Any development below the minimum height limit by 50%	40	

Table 2: Metropolitan Centre Zone (MCZ) and, Neighborhood Centre Zone (NCZ), Local Centre Zone (LCZ) and High Density Residential Zone (HRZ) - Thresholds for any over height development:

Threshold	Points required				Comments
	MCZ	NCZ	LCZ	HRZ	
Any development that exceeds the maximum height limit by 25%-49%	20	10	10	20	<u>The City Outcomes Contribution does not apply to d</u> Developments that are within the 25% height threshold; <u>however, these will be assessed against the Centres and Mixed Use Design Guide.</u> do not need to meet the outcomes, however they need to satisfy the relevant guidelines in this guide.
Any development that exceeds the maximum height limit by +50%	30	15	15	25	-

The table below sets out the relevant City Outcomes sought in response to the development thresholds outlined in Tables 1 and 2. To achieve the minimum numeric value associated with the relevant threshold in these tables, a score based on the combined ~~aggregate~~ points of two or more of the outcomes listed in Table 3 is required.

Table 3: City Outcomes

Outcome	Points	How points can be achieved Comments
Contribution to Public Space and Amenity (1-10 points)**		
For every 10% of the site accessible as public open space	1-10	The range in points depends on the quality, extent and level of amenity that each solution provides.
Any lane-way or through_block connection	1-10	<p>The range in points depends on the quality, extent and level of amenity that each solution provides.</p> <p><u>Matters taken into account when attributing points to a lane-way or through-block connection:</u></p> <ul style="list-style-type: none"> - <u>Extent of public access. Connections with full public access will achieve higher points than those with limited (e.g. daytime only) access, or private connections.</u> - <u>Activation at ground level – for example through store frontages in tenancies facing the laneway, or cafes opening out to the laneway.</u> - <u>Landscaping and street furniture within the lane-way or through-block connection.</u> - <u>Accessibility.</u> <p><u>Note: The design of any lane-ways or through-block connections must take into account the principles of Crime Prevention Through Environmental Design (CPTED).</u></p>
Provision of appropriate communal gardens, playgrounds, and roofgardens	1-5 {1-10 for HRZ}	<p>The range in points depends on the quality, extent and level of amenity that each solution provides.</p> <p><u>Matters taken into account when attributing points to communal gardens, playground and roof gardens:</u></p> <ul style="list-style-type: none"> - <u>Extent of public access. Connections with full public access will achieve higher points than those with limited (e.g. daytime only) access, or private access.</u>

		<ul style="list-style-type: none"> - <u>Activation between buildings and the garden, playground or roof garden.</u> - <u>Landscaping and street furniture within the lane-way or through-block connection.</u> - <u>Whether the work contributes to a Council programme of works (e.g. the Green Network Plan).</u> - <u>Accessibility.</u> <p><u>Note:</u></p> <ul style="list-style-type: none"> - <u>The design of any publicly accessible spaces must take into account the principles of CPTED.</u> - <u>Public playgrounds must meet any applicable national standard for playground safety.</u>
<p>Provision of permanent public amenities, i.e.e.g. <u>public toilets, street furniture, electric vehicle (ev) charging, park benches, landscaping, bike parking, public art (e.g. sculptures or murals) and street improvement works, the provision of spaces for community use (e.g. artist studios)</u></p>	<p>1-5</p>	<p>The range in points depends on the quality, extent and level of amenity that each solution provides.</p> <p><u>Matters taken into account when attributing points to public amenities:</u></p> <ul style="list-style-type: none"> - <u>Whether the work contributes to a Council programme of works (e.g. the Green Network Plan, cycleways or street improvement works).</u> - <u>The adaptability of the space.</u> - <u>Accessibility.</u> <p><u>Note:</u></p> <ul style="list-style-type: none"> - <u>The range in points depends on the quality, extent and level of amenity that each solution provides.</u> - <u>Where more than one public amenity feature is provided separate points will be attributed to each amenity feature.</u> - <u>The installation of any features on public land will need confirmation that approval will be provided by the landowner (i.e. the Council) before points are awarded for this feature.</u>

Universal Accessibility (5-10 points)		
Lifemark 5-Star or equivalent or higher	10	
Lifemark 4-Star or equivalent	7.5	
Lifemark 3-Star or equivalent	5	
Sustainability and Resilience (1-10 points)		
Green Star 6 or Home Star 9 or equivalent or higher	10	<u>Points for GreenStar or HomeStar certification can be achieved when this not awarded until after construction.</u>
Green Star 5 or Home Star 8 or equivalent	7.5	<u>Points for GreenStar or HomeStar certification can be achieved when this not awarded until after construction.</u>
Green Star 4 or Home Star 7 or equivalent	5	<u>Points for GreenStar or HomeStar certification can be achieved when this not awarded until after construction.</u>
<u>Adaptive reuse of buildings Restoration of a degraded heritage building, heritage structure, or site/area of significance to Māori, that is listed in Schedule 1, 2 or 7, and is on the same site or adjoining site to the development.</u>	1-10	<p><u>Matters taken into account when attributing points to the restoration of schedule heritage:</u></p> <p><u>The range in points depends on-</u></p> <ul style="list-style-type: none"> - <u>The quality, and extent and level of reuse and regeneration of the restoration.</u> - <u>How the restoration, and how it provides for ongoing use and maintenance of the heritage or site/area of significance.</u> - <u>Any features that enhance the heritage/SASM, such as signage (interpretative signs).</u>
<u>Reduction in embodied carbon in buildings compared to an equivalent standard construction.</u>	1-10	<p><u>Matters taken into account when attributing points to the reduction of embodied carbon:</u></p> <ul style="list-style-type: none"> - <u>The range in points depends on the quality, extent proportion and quantum of reduced embodied carbon level of amenity that each solution provides.</u>
<u>Seismic resilience measures Additional to 100% New Building Standard, including such as base isolations, seismic dampers, etc. Use of low-damage building design techniques so that the building exceeds the 100% New Building Standard for seismic resilience, and is more easily repaired and re-used after an earthquake.</u>	1-5/10	<p><u>Matters taken into account when allocating points for building seismic resilience:</u></p> <ul style="list-style-type: none"> - <u>The range in points depends on the quality, extent and level of amenity that each solution provides increase in life safety the measures provide.</u> - <u>Use of recognised low-damage building design technology</u> - <u>Design to a higher Importance</u>

		<p><u>Level than required (e.g. from IL2 to IL3 or IL4).</u></p> <ul style="list-style-type: none"> - <u>The low-damage building design techniques being unobtrusive when viewed from public spaces.</u>
Assisted Housing		
For every 1% of the net floor area in the development that is new assisted housing.	1	<p><u>Note:</u></p> <ul style="list-style-type: none"> - <u>To guarantee any assisted housing remains for at least 25 years, the developer will be required to register encumbrances registered as a first charge on the relevant Records of Title titles of the assisted housing will be applied to guarantee they remain assisted housing for at least 25 years.</u>
Urban Design Panel (1-10 points)		
Urban Design Panel Approval	1-10	The range in points depends on the development's response to all the design guides as decided by the Panel.